

Syracuse University

SURFACE

Architecture Senior Theses

School of Architecture Dissertations and
Theses

5-2015

Library Public-ness: Bridging the Digital Divide (Thesis Book)

Chao Dou

Follow this and additional works at: https://surface.syr.edu/architecture_theses



Part of the [Architecture Commons](#)

Recommended Citation

Dou, Chao, "Library Public-ness: Bridging the Digital Divide (Thesis Book)" (2015). *Architecture Senior Theses*. 272.

https://surface.syr.edu/architecture_theses/272

This Thesis is brought to you for free and open access by the School of Architecture Dissertations and Theses at SURFACE. It has been accepted for inclusion in Architecture Senior Theses by an authorized administrator of SURFACE. For more information, please contact surface@syr.edu.

LIBRARY PUBLIC-NESS

CHAO DOU

SYRACUSE UNIVERSITY
SCHOOL OF ARCHITECTURE

PART I: Research

INTRODUCTION

Community Commons
Information Space
Digital and Physical Platforms
Digital Divide

HISTORY

First Public Libraries
Andrew Carnegie
New York Public Library

PRECEDENTS

New York Public Library
Sendai Mediatheque
Seattle Public Library

CONVERSATION WITH EXPERTS

Onondaga Public Library Main Branch
Information Technology Department
Response to Requests

PROPOSAL

Existing Program
Proposed Program
Site Context

PART II: Design

DIAGRAMS

Site Connections
Form Design
Plaza Iterations
View Frames
Circulation

DESIGN

Plans
Program
Enclosed vs. Open
Programmatic Axons
Materials
Structure System
Sections

RENDERINGS

SE Ground Level
SW Perspective
Isometric
Interior
Extras

CONTENTS

PART I: Research

“Bad Libraries Building Collections
Good Libraries Build Services
Great Libraries Build Communities”

David Lankes

INTRODUCTION

ARE PUBLIC LIBRARIES DYING? HAS THE ROLE OF THE PUBLIC LIBRARY CEASED TO MEET THE DEMANDS OF THE DIGITAL AGE OF INSTANT INFORMATION? HAVE THE CARD CATALOG; DEWEY DECIMAL SYSTEM, ENCYCLOPEDIA COLLECTIONS AND REFERENCE BOOKS SIMPLY BECAME MUSEUM LIKE DISPLAYS OF YEARS PAST?

FOR MOST AMERICANS, THE ABILITY TO ACCESS INFORMATION BY MOBILE, WORK AND HOME INTERNET ARE A NORMAL REALTY, THIS IS NOT THE CASE FOR THE POOR WHO LIVE IN THE SURROUNDING COMMUNITIES OF DOWNTOWN SYRACUSE WHERE THE DISPARITY OF THE OF THE DIGITAL DIVIDE IS AS APPARENT.

The public library must continue to deliver on its core mission of free access to information for all. The modern digital access to information does not require any particular form, at the same time the structures of the public library must be ever more ACCESSIBLE, INVITING, and FLEXIBLE.

PROPOSAL

This thesis proposes that the current public library in downtown Syracuse in the Galleries is not effective or sufficient to properly serve the needs of the surrounding public.

A new downtown Syracuse Public Library will provide the platform to bridge the digital divide by providing proper spatial elements for ease of access to digital and shared functions for all the people of the city. This suggests a new sense of “public-ness” for our community building in the digital age.

INTRODUCTION THESIS

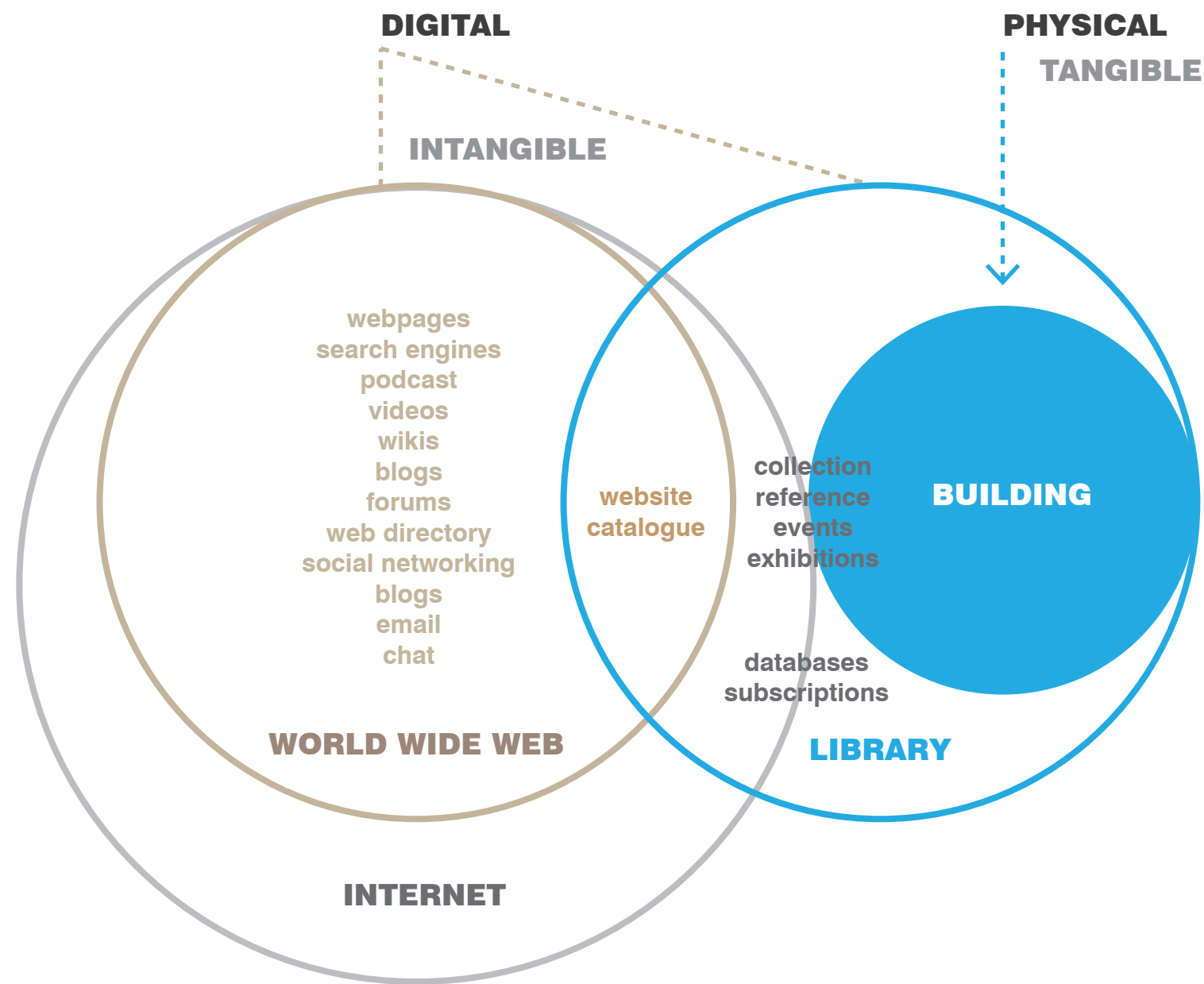

LIBRARY IS ONE OF THE PHYSICAL SOURCES OF INFORMATION EXCHANGE

In the Digital Age, information is becoming digitized, the sharing, storing, and dissemination of information is changing the way people communicate, access and consume information creating a shift industries such as the education, journalism, business and well as architectural typology changes in physical information spaces like the library. Information is constantly being created due to efficiency of internet information transfer. Relevant and timely information is the key to the advances in information exchange in digital platforms as opposed to physical platforms.

SOCIAL NETWORKING PLATFORMS BRINGS TOGETHER MINDS THAT MAY NOT OTHERWISE MEET, WHICH ALLOWS FOR THE FREE EXCHANGE OF IDEAS AND EMPOWERMENT OF MARGINALIZED DISCOURSE.

INTRODUCTION INFORMATION SPACE

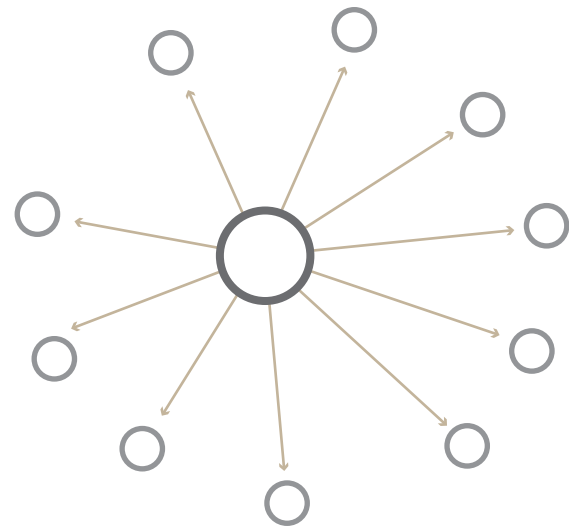

RADIAL DISSEMINATION OF INFORMATION

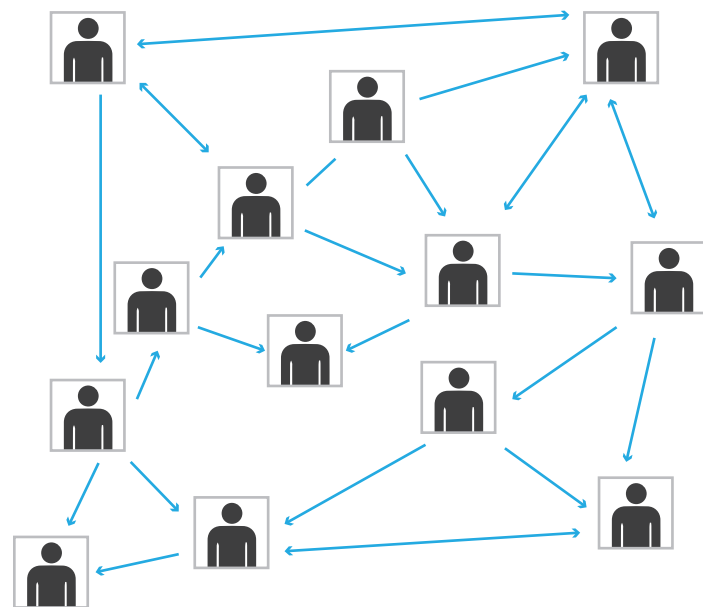

EXCHANGE BETWEEN USERS IN TWITTER

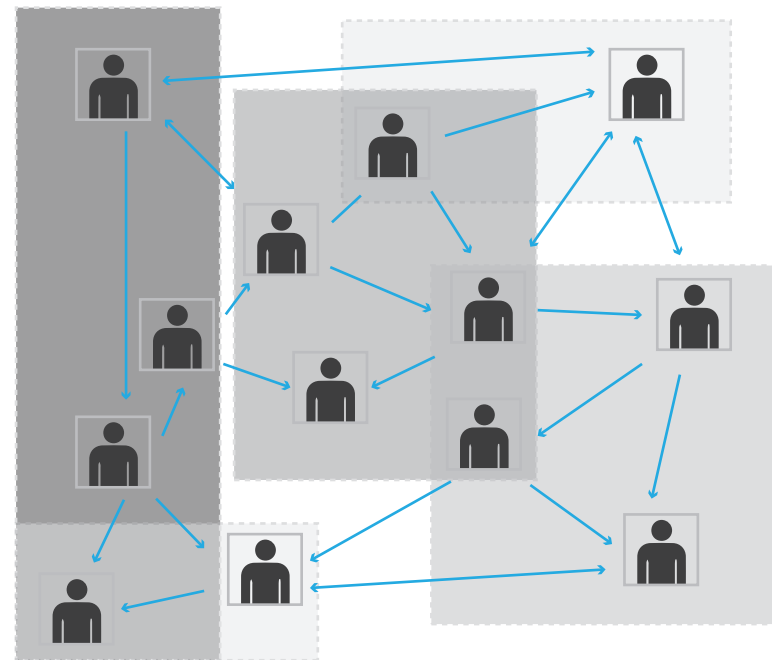

USERS OVERLAP IN TWITTER COMMUNITIES
BASED ON SHARED INTEREST

SOCIAL NETWORKING PLATFORMS SERVE AS BOTH MANIFESTATION OF AND MEANS BY WHICH TO COMBAT THE DIGITAL DIVIDE. EACH OF THE SITES HOST THRIVING COMMUNITIES THAT ENGAGE WITH OTHERWISE MARGINALIZED POPULATION

Digital information platforms like Twitter is a social networking platform designed around relevant and timely exchange of information. Users follow each other to gain access to their shared information. Retweet is sharing information where the user feels is relevant to his/her own twitter community. Intangible digital communities are formed around people with similar interests, trust between the users are built around the consumption and contribution of information.

INTRODUCTION DIGITAL INFORMATION PLATFORMS



MULTI-PURPOSE DEVICES

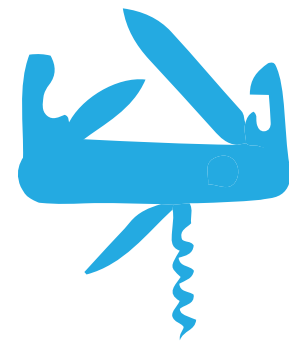

SWISS ARMY KNIFE

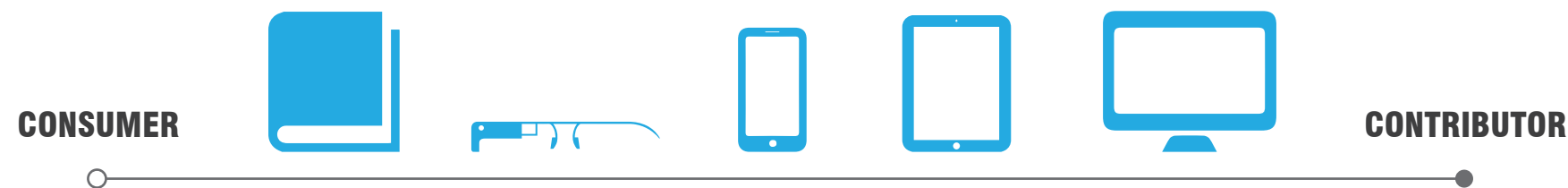

TECHNOLOGY CONSUMER VS. INFORMATION CONTRIBUTOR

SOCIAL MEDIA ENABLES USER TO PARTICPATE ONLINE AND CREATE CONTENT WITHOUT HAVINGING TO UNDERSTAND HOW THE TECHNOLOGY WORKS

Spaces that have wireless access to internet are transduced by mobile and immobile devices accessing that network. The increasing adaptation and advancement in technology has allowed for economic capable and digital literal individuals to explore in the digital platforms with the facilitation of the various user interface design and the increasing connected world of the internet. The mass production and consumption nature of the devices and the increasingly seamless connection of internet the led the changes in the digital platforms to become more prominent.

MY INVESTIGATION IS AIMED TO UNDERSTAND THE CONTEMPORARY ARCHITECTURAL CONDITIONS OF PUBLIC LIBRARY SPACES IN THE DIGITAL BASED KNOWLEDGE ECONOMY.

INTRODUCTION DIGITAL LITERACY



PUBLIC LIBRARY HISTORY

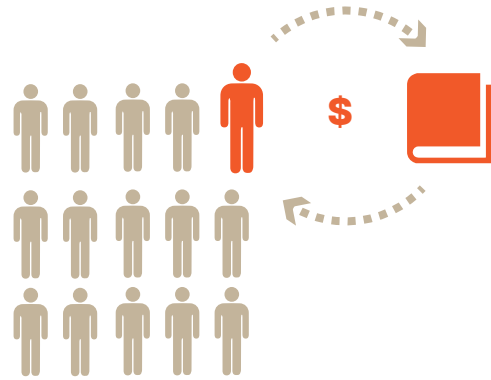

CIRCULATING LIBRARY

Developed in the late 1700s. These were often housed in bookstores or print shops, and rented out books.

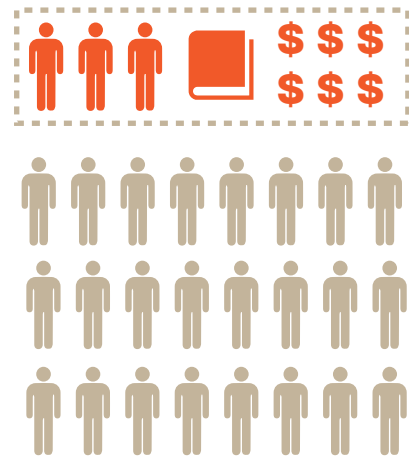

SUBSCRIPTION LIBRARY

Focused on a particular subject, usually scholarly materials. Structured around membership requirements with subscription fees.

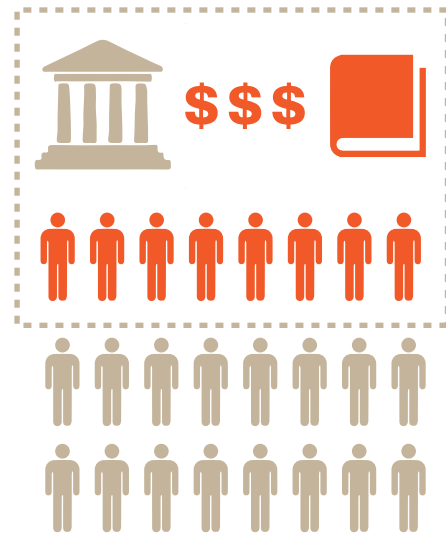

DISTRICT LIBRARY

Educators and eventually legislators looked to the school district library (funded through taxes) to provide reading for adults as well as children.

1762

Circulating Library

The first circulating library was in Annapolis, Maryland. They offered popular materials such as the latest fiction, including that 18th century innovation novels for rental.

1731

Library Company of Philadelphia

Benjamin Franklin initiated a "subscription library" as a way of sharing books among members of a literary society. It was incorporated in 1742 as the Library Company of Philadelphia, the first established in the U.S. You could join the library by buying stock in the company and books were only available to members.

1800

Mercantile Library

Aimed at middle class young men, "to promote orderly and virtuous habits, diffuse knowledge and the desire for knowledge, improve the scientific skill" and create good citizens. Mercantile libraries were usually funded by contributions from the benevolent rich, to help educate the masses.

1807

Athenaeum

An Athenaeum was basically a gentlemen's social club (women were seldom allowed in the early days) with a collection of reading material. Members were from the richest and highest class of society. The cost was high, around \$300 for a share of stock, to keep out the riff-raff.

1830

School Public Libraries

School districts were expected to have books available for their students. There was no system; it was all haphazard, and materials donated usually was not interesting.

PUBLIC LIBRARY HISTORY

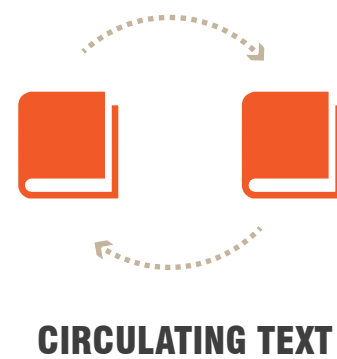

1890

Children's Library

The first children's libraries were founded in the 1890s. As late as 1894, 70% of libraries still had age restrictions, but by 1908, circulation of materials to children accounted for around one-third of total library lending.

1890

Community Center

The library was also a haven for the waves of immigrants arriving after 1890 and, equally importantly, for their children. Storytelling was used to socialize immigrants and teach the customs and expectations of U.S. society. Libraries came to resemble community centers.

1900

Reference Departments

Libraries also were growing in scope. Reference departments were standard by 1900, as were open shelves

ANDREW CARNEGIE

CARNEGIE BELIEVED THAT LIBRARIES AND BOOKS SHOULD BE AVAILABLE TO EVERYONE. By 1920, the Carnegie estate had donated \$50 million to erect 2,500 library buildings, including 1,700 in the U.S.--by far the most sustained and widespread philanthropic enterprise ever devoted to libraries. Carnegie's donations got libraries started in small towns, not just big cities, throughout America. Carnegie is the driving force behind the modern U.S. public library system.

PUBLIC LIBRARY HISTORY

PUBLIC LIBRARY HISTORY

NEW YORK PUBLIC LIBRARY

Throughout the system, the Library provides free and open access to its physical and electronic collections and information, as well as to its services for people of all ages, from toddlers to teens and adults. Research and circulating collections combined total more than 51 million items, among them materials for the visually impaired. In addition, each year the Library presents thousands of exhibitions and public programs, including classes in technology, literacy, researching, and English for Speakers of Other Languages. The Library serves some 18 million patrons who come through its doors annually; in addition, the Library's website receives 32 million visits annually from more than 200 countries.

1849

Astor Library

The Astor Library was created through the generosity of John Jacob Astor (1763-1848), a German immigrant who at his death was the wealthiest man in America. In his will he pledged \$400,000 for the establishment of a reference library in New York. Although the books did not circulate and hours were limited, it was a major resource for reference and research.

1854

Lenox Library

New York's other principal library during this time was founded by James Lenox and consisted primarily of his personal collection of rare books (which included the first Gutenberg Bible to come to the New World), manuscripts, and Americana. While use was free of charge, tickets of admission were required.

1886

Samuel J. Tilden

One-time governor Samuel J. Tilden (1814-1886), who upon his death bequeathed the bulk of his fortune — about \$2.4 million — to "establish and maintain a free library and reading room in the city of New York."

1892

New York Public Library

By 1892, both the Astor and Lenox libraries were experiencing financial difficulties. The combination of dwindling endowments and expanding collections had compelled their trustees to reconsider their mission. The NYPL was formed as an unprecedented example of private philanthropy for the public good.

1901

Neighborhood Libraries

The New York Public Library contracted with the City of New York to operate 39 Carnegie branches in the Bronx, Manhattan, and Staten Island.

1901

Andrew Carnegie

A month later, steel baron Andrew Carnegie offered \$5.2 million to construct a system of branch libraries throughout New York City which provided the City would supply the sites and fund the libraries' maintenance and operations.

2014

Current NYPL

The New York Public Library's 42nd Street building's renovation aims to enhance that role, strengthening research services, opening more of the architectural gem to the public, and bringing back the circulating library.



PRECEDENTS

NEW YORK PUBLIC LIBRARY

LOCATION: **New York, NY, USA**
ARCHITECT: **Carrère and Hastings**
YEAR: **1897-1911**
SIZE: **29,348 sqm**
BRANCH: **87**

HIGHLIGHT: HISTORICAL VALUE

The Schwarzman main branch is a prominent historic landmark in Midtown Manhattan, one of four research libraries in the library system. The dominant feature is the Rose Main Reading Room, characterized by a fifty-two foot tall ceiling filled with long oak tables surrounded by two layers of book stacks against the walls.

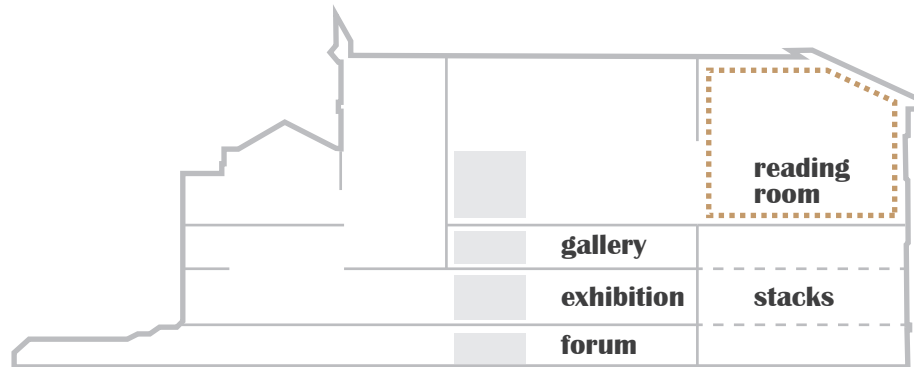
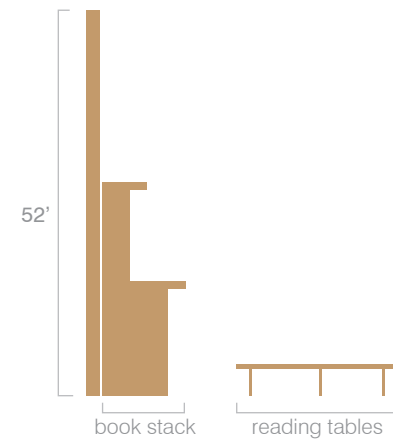

sectional programmatic diagram



SENDAI MEDIATHEQUE

LOCATION: **Sendai, Miyagi, Japan**

ARCHITECT: **Toyo Ito**

YEAR: **1995-2001**

SIZE: **21,682 sqm**

HIGHLIGHT:

FREE CIRCULATING SPACE

MEANDER BETWEEN STRUCTURAL TUBES

"...this building has many free spaces, that is, spaces that are not intended, as rooms are, to serve specific functions. Such spaces exist, for example, between the tubes and the building perimeter. Visitors will be able to use such spaces as they use the city streets, for various activities." -Toyo Ito

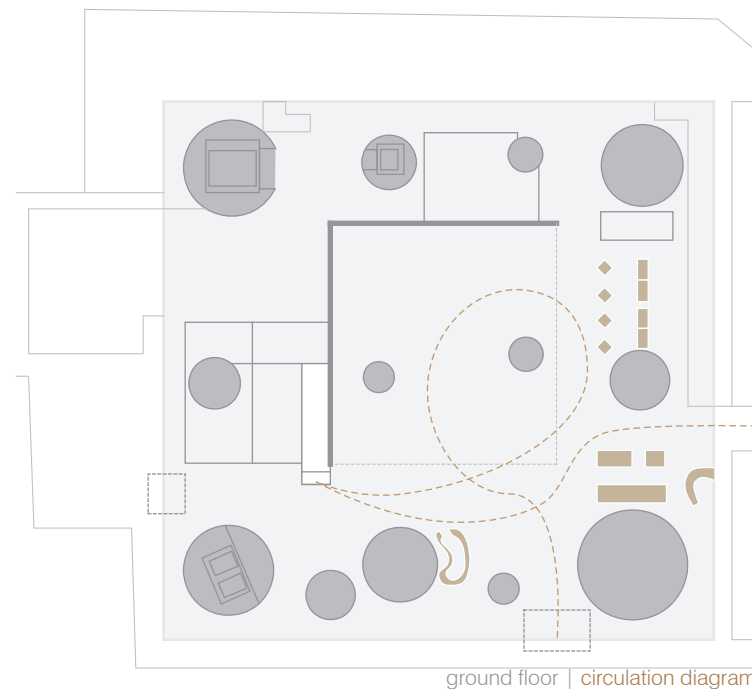

ground floor | circulation diagram

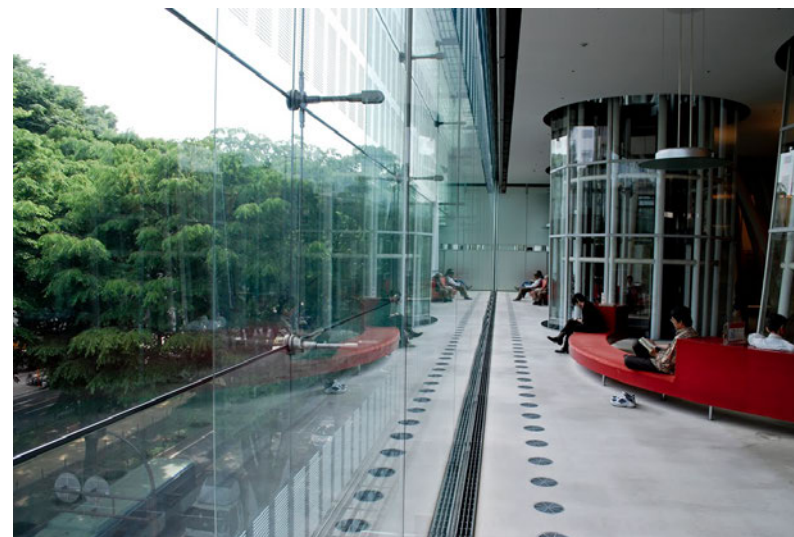

SEATTLE CENTRAL LIBRARY

LOCATION: **Seattle, Washington, USA**

ARCHITECT: **OMA + LMN**

YEAR: **1999-2004**

SIZE: **38,300 sqm**

BRANCHES: **26**

HIGHLIGHT:

PROGRAMMATIC CLUSTERS

FIVE STABLE AND FOUR INSTABLE

- 5** Each of the five stable platform is a programmatic cluster that is architecturally defined and equipped for maximum, dedicated performance.
- 4** The spaces in between the five platforms function as open floors and is organized as spaces for work, interaction, and play.

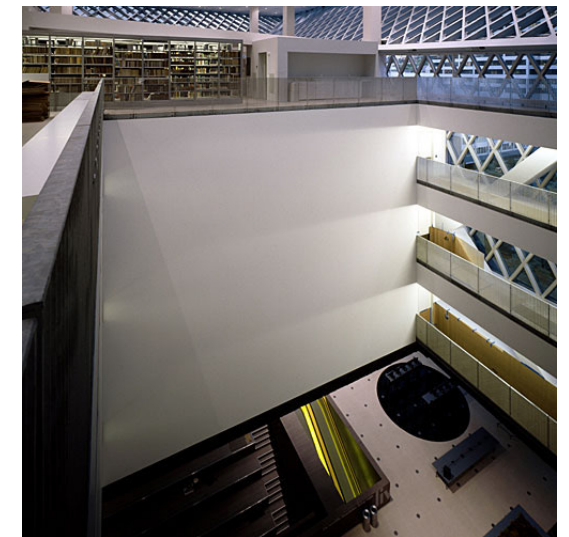
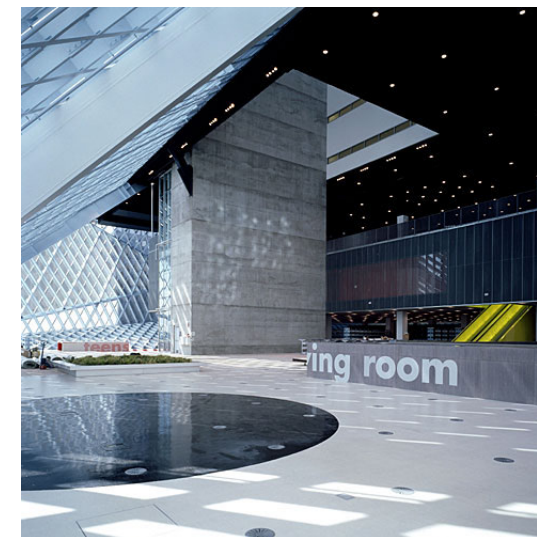
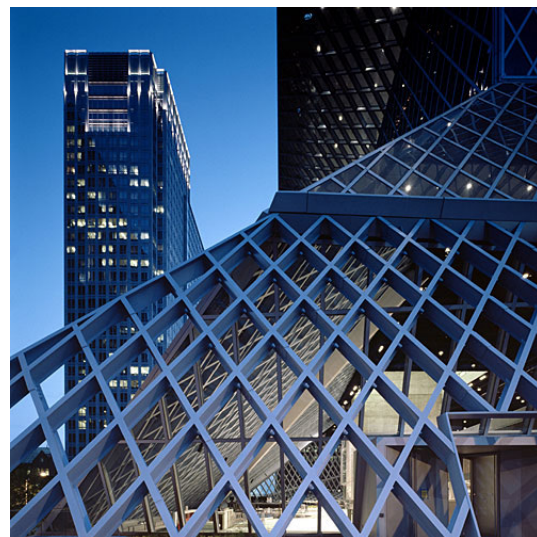
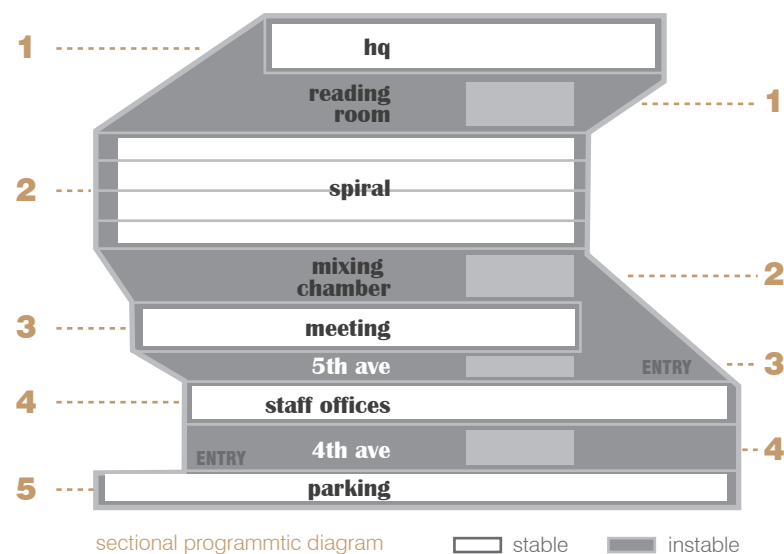

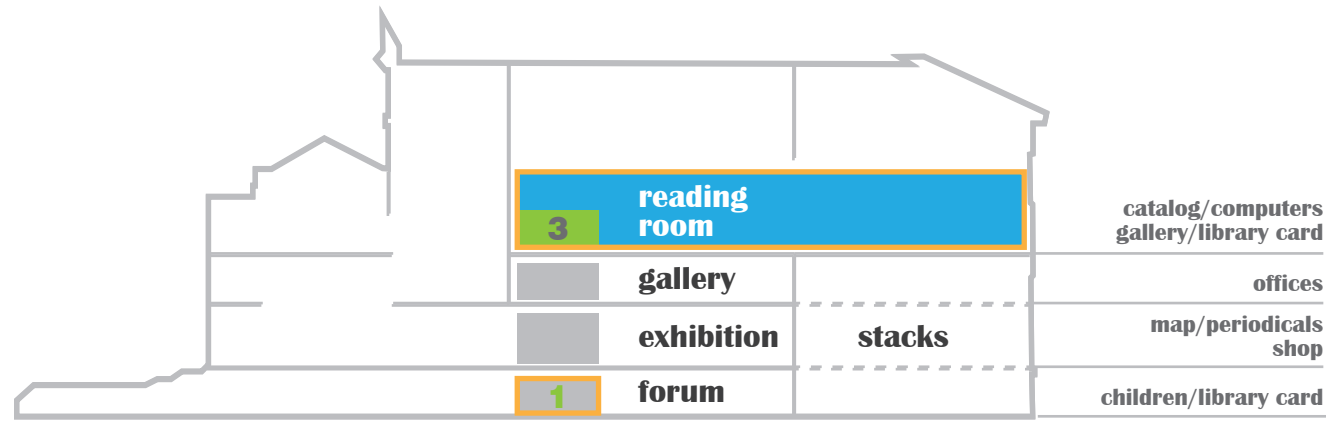

New York Public Library



HORIZONTAL MOVEMENT



PRECEDENTS PROGRAM

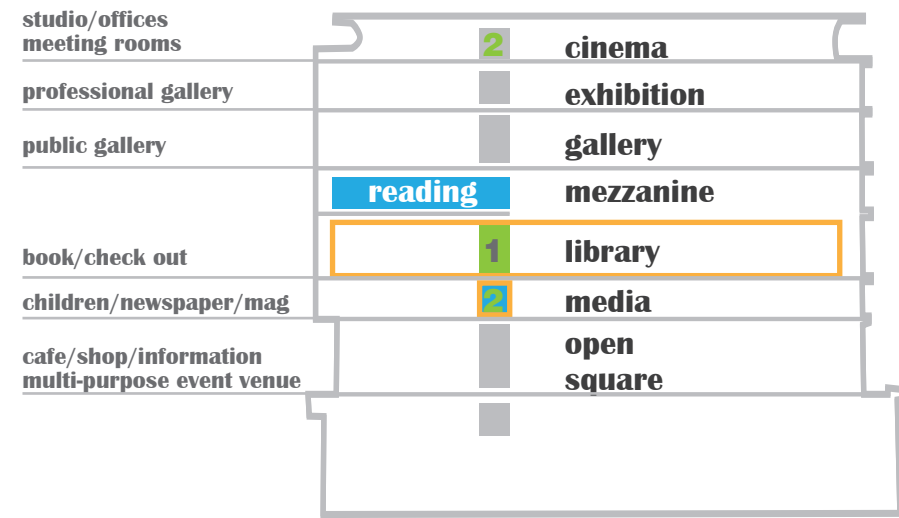

Sendai Mediatheque

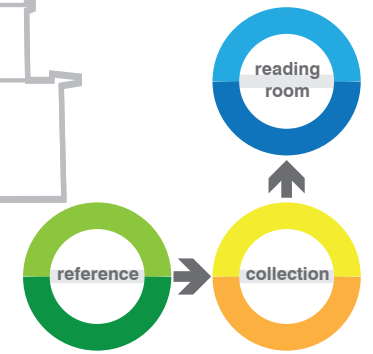

COMBINATION MOVEMENT

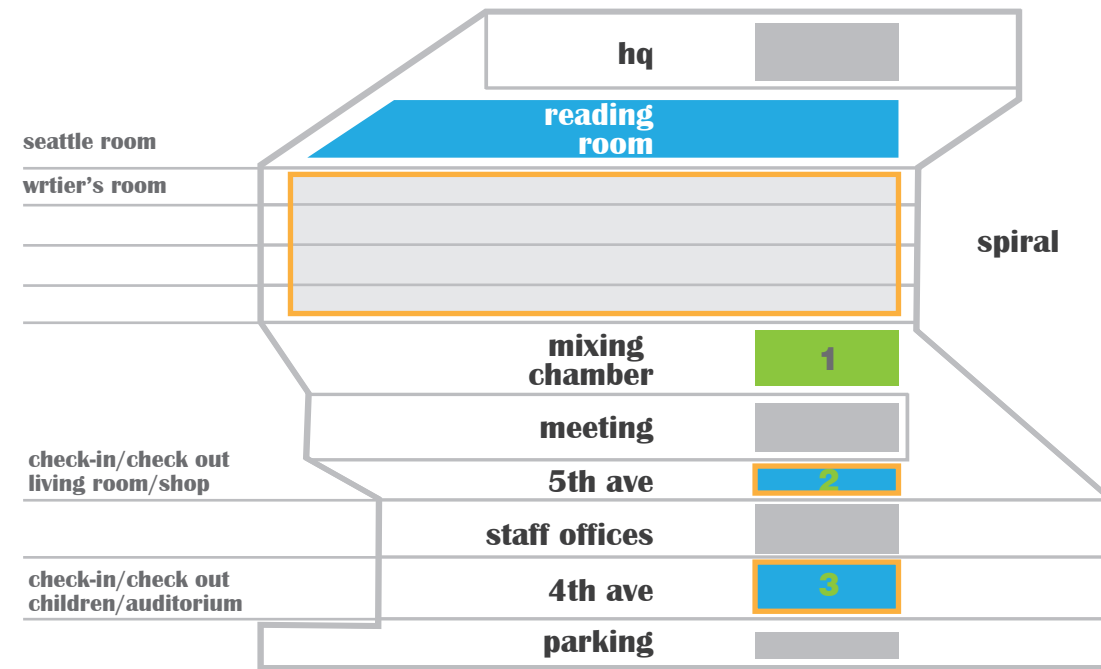

Seattle Public Library



VERTICAL MOVEMENT

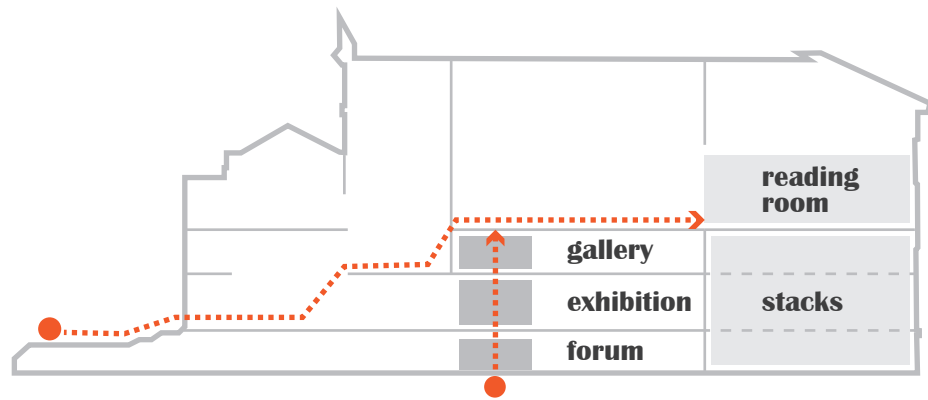

New York Public Library: **2 entrances**

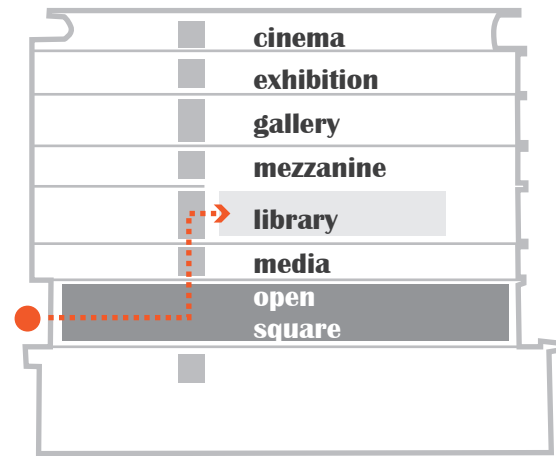

Sendai Mediatheque: **2 entrances**

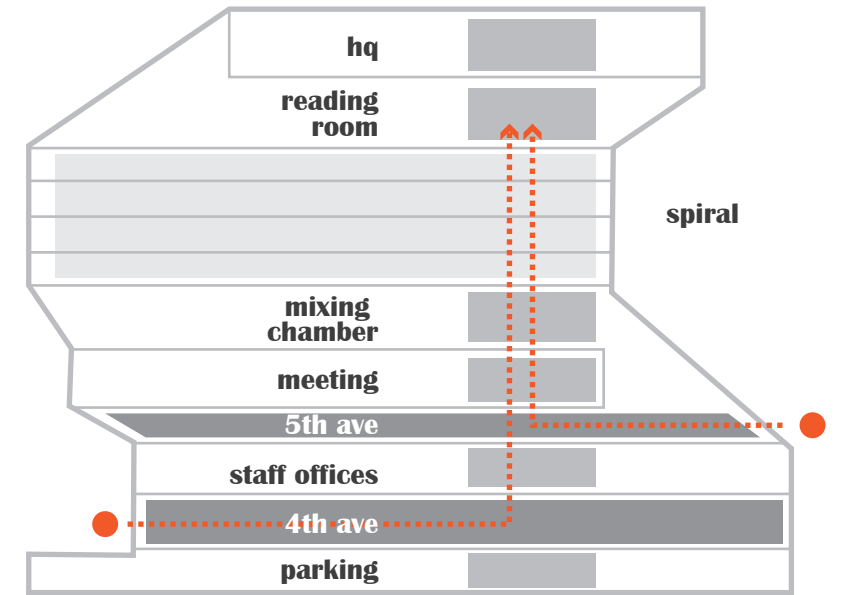

Seattle Public Library: **2 entrances**

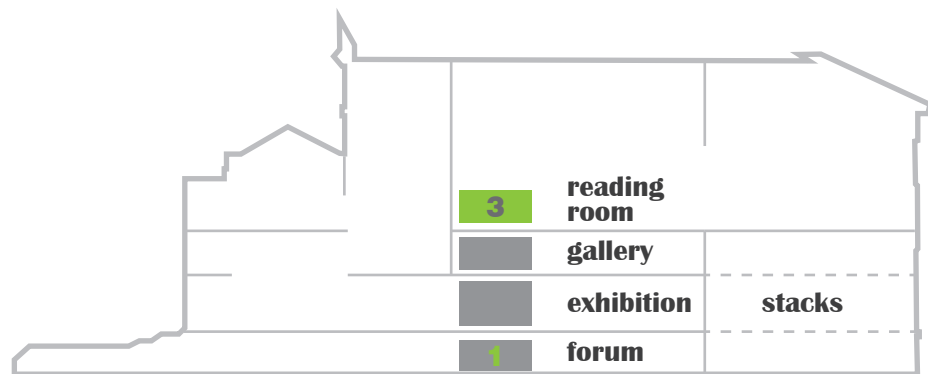

New York Public Library: **4 reference desks**

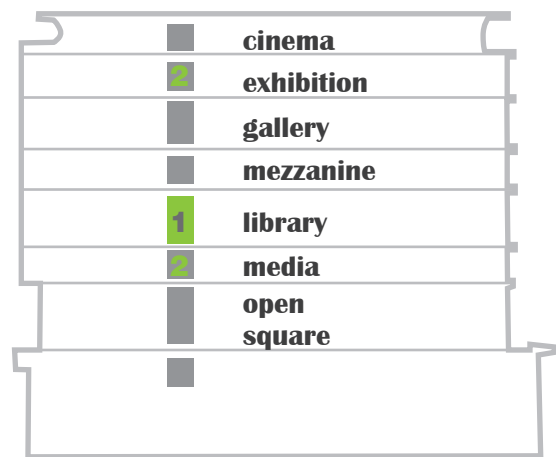

Sendai Mediatheque: **5 reference desks**

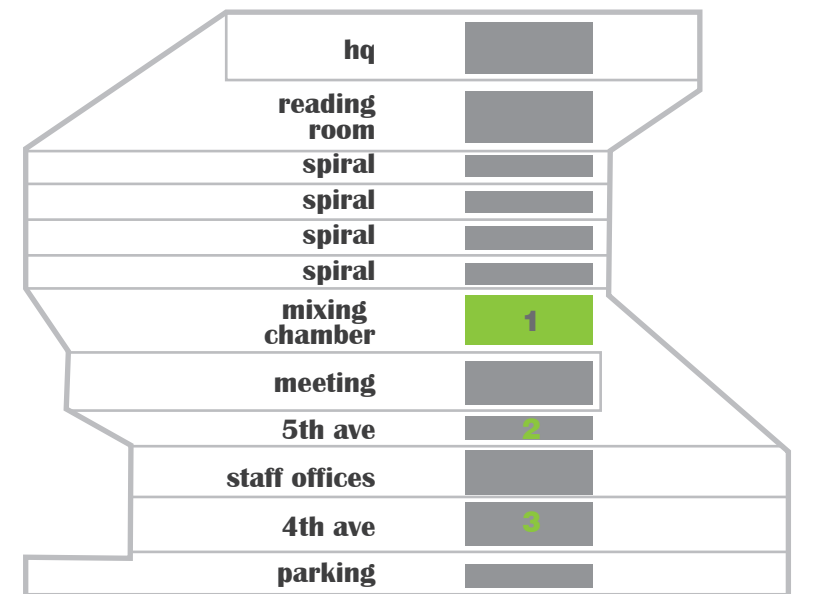

Seattle Public Library: **5 reference desks**

PRECEDENTS CIRCULATION

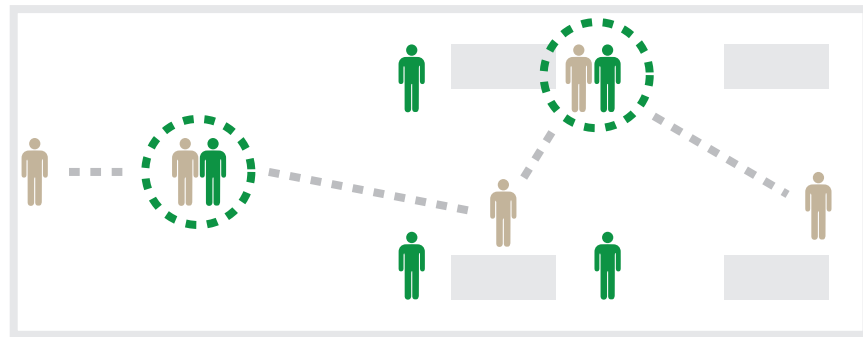

REFERENCE DESK TRADITIONAL

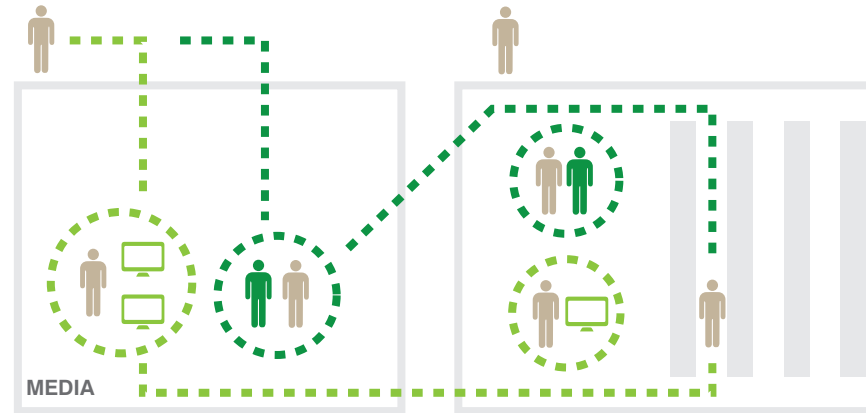
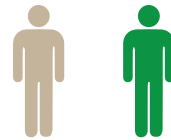

REFERENCE WITH COMPUTER AND LIBRARIAN SPREAD OUT ON SEVERAL FLOORS

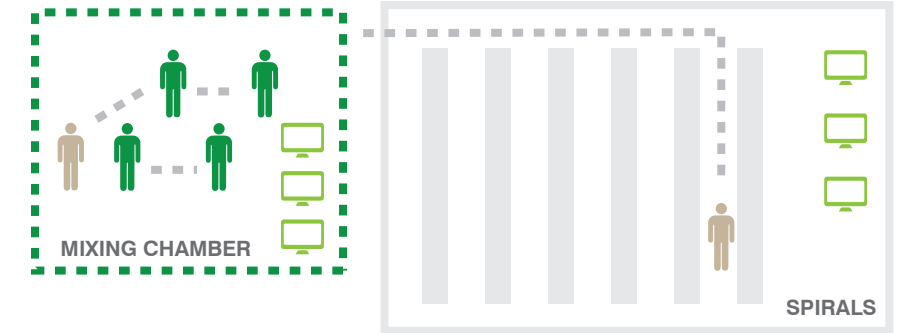
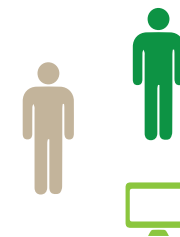

REFERENCE WITH COMPUTER AND LIBRARIAN ON ONE FLOOR

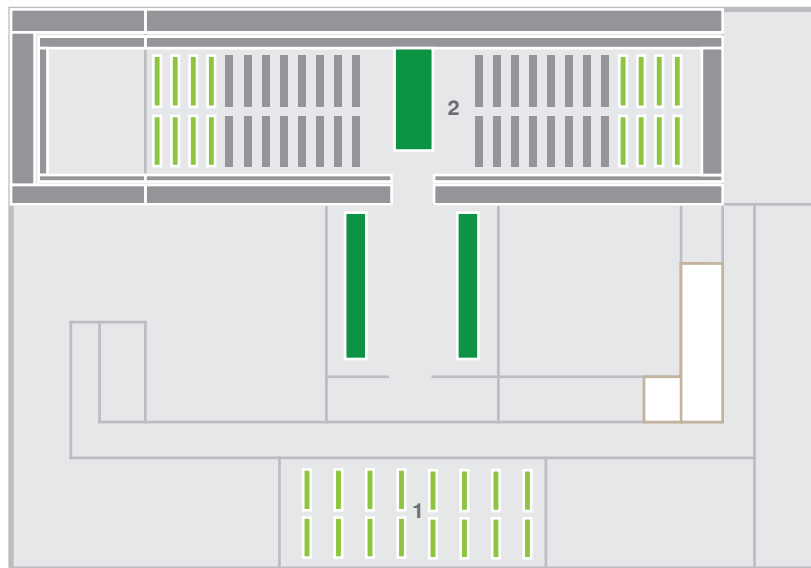
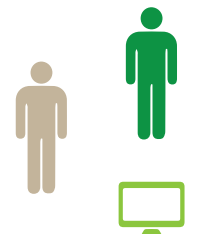

3rd floor



INFORMATION | 2nd floor

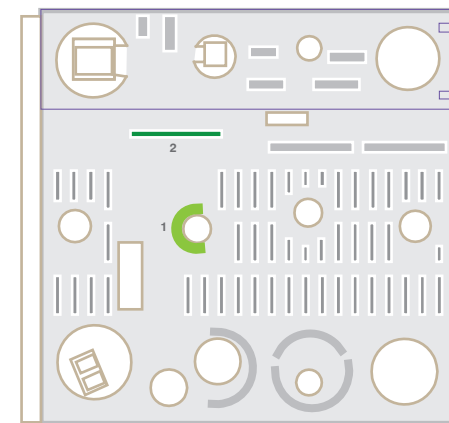

LIBRARY | 3rd + 4th floor

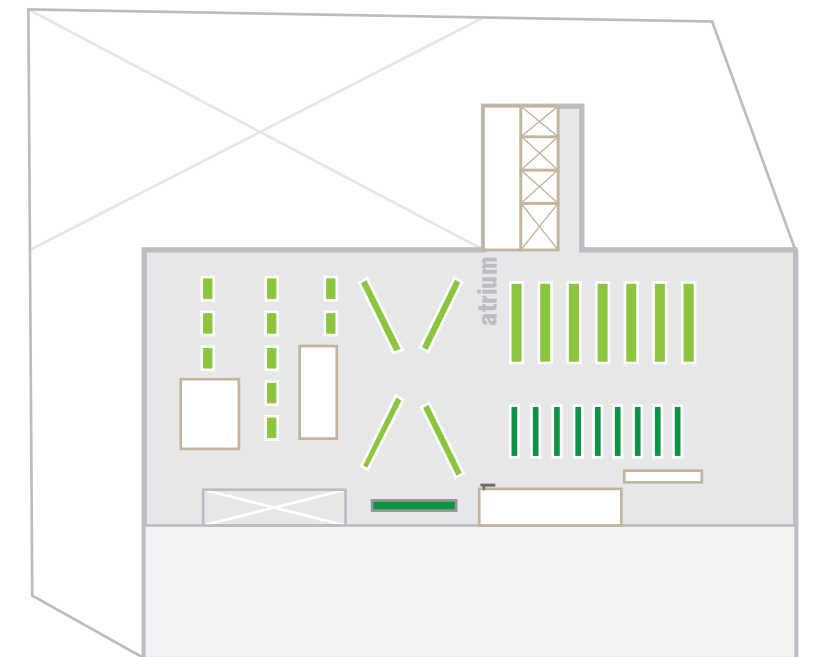

MIXING CHAMBER | 5th floor

PRECEDENTS REFERENCE

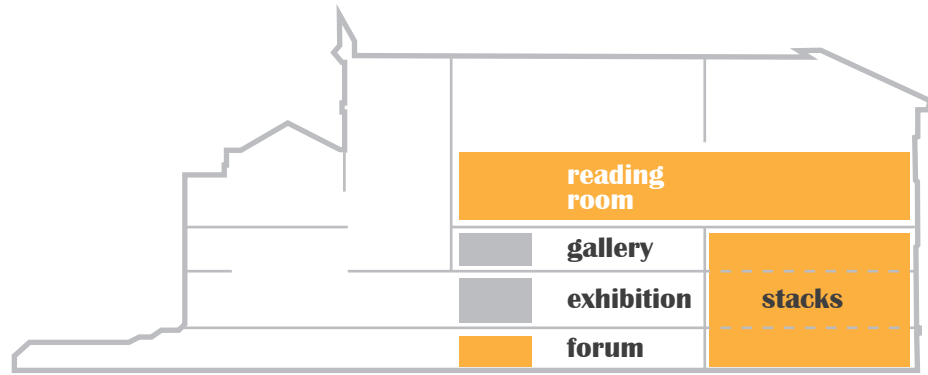

New York Public Library: **2 collection floors**

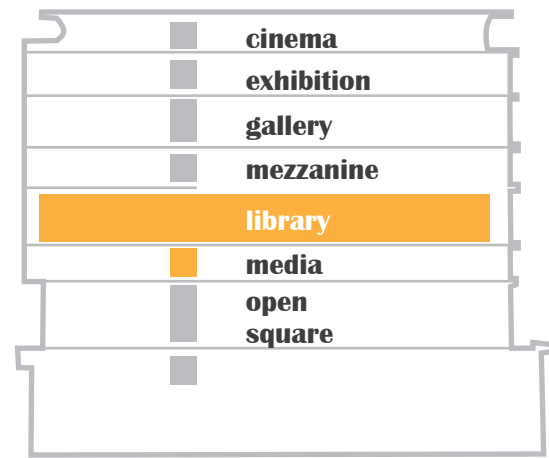

Sendai Mediatheque: **2 collection floors**

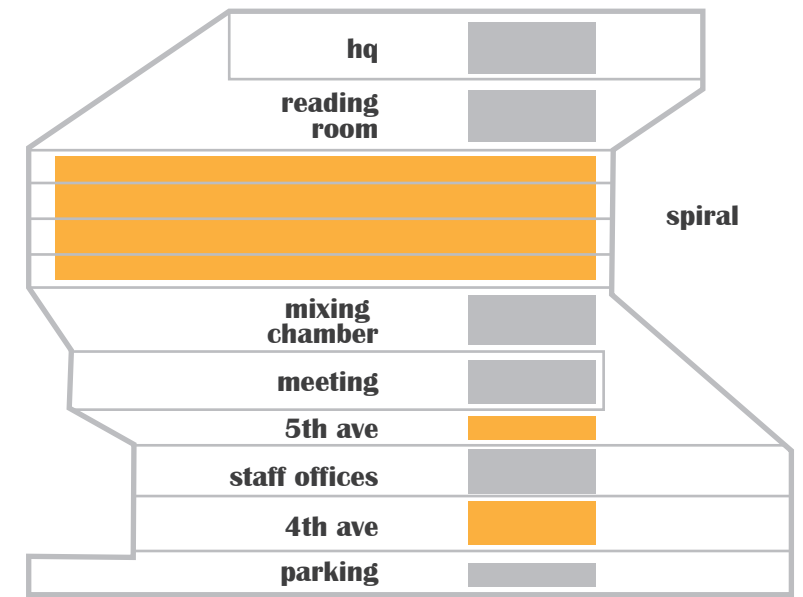

Seattle Public Library: **3 collection floors**

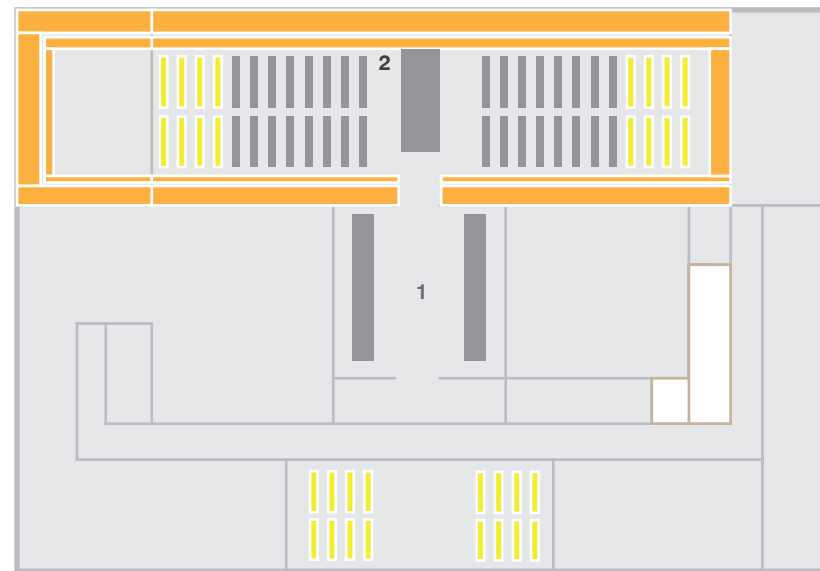

3rd floor
■ digital source
■ physical sources
 1. computer desks
 2. books stacks
 circulation

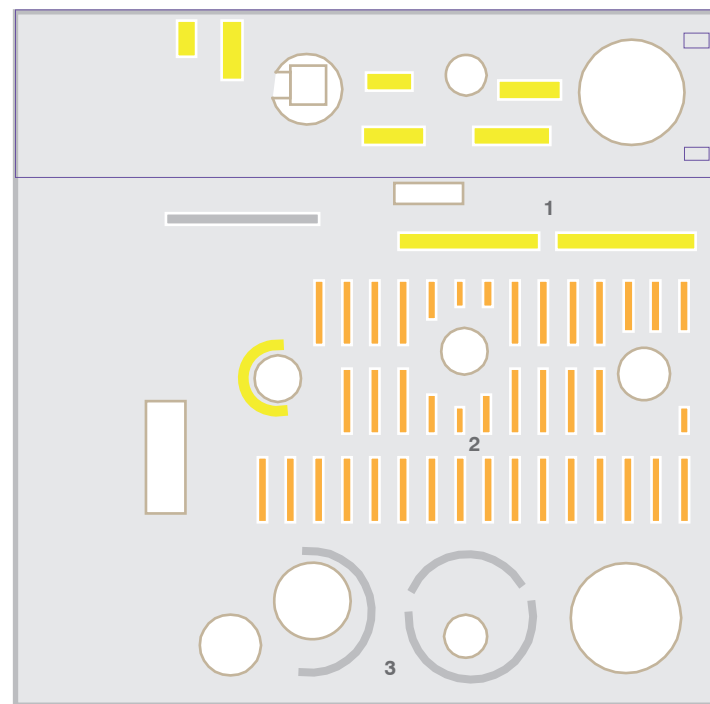

LIBRARY | 3rd floor

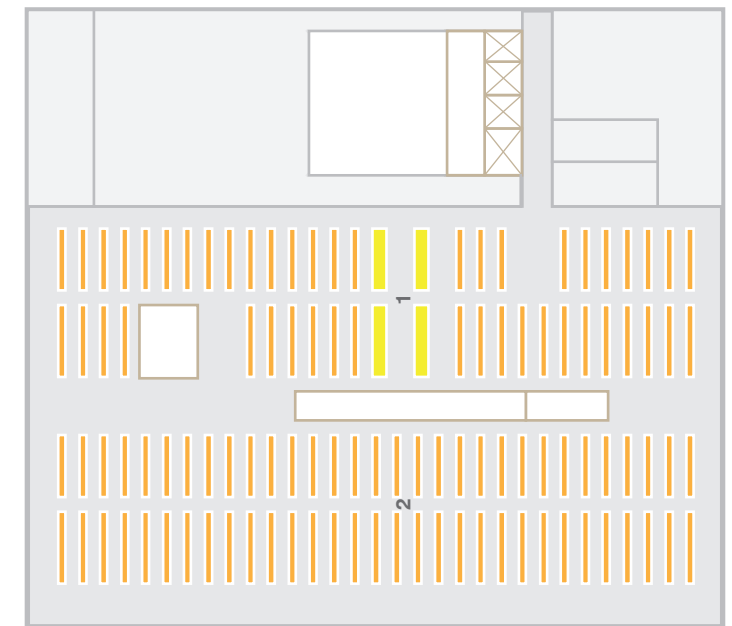

SPIRAL | 6th -9th floor

PRECEDENTS COLLECTION

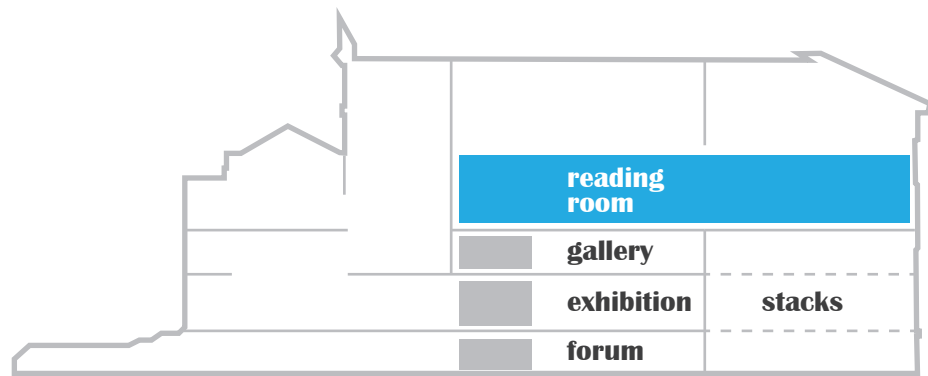

New York Public Library: **3rd floors**

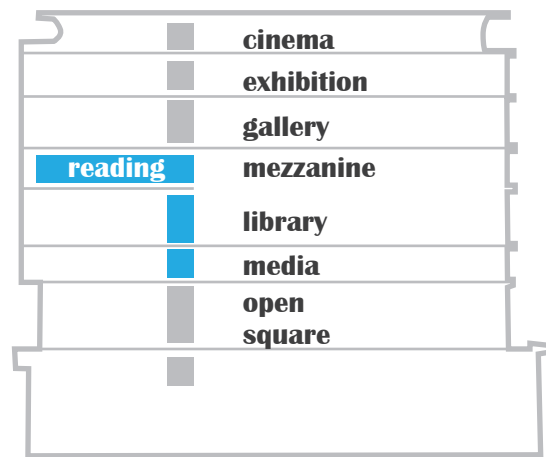

Sendai Mediatheque: **4th floors**

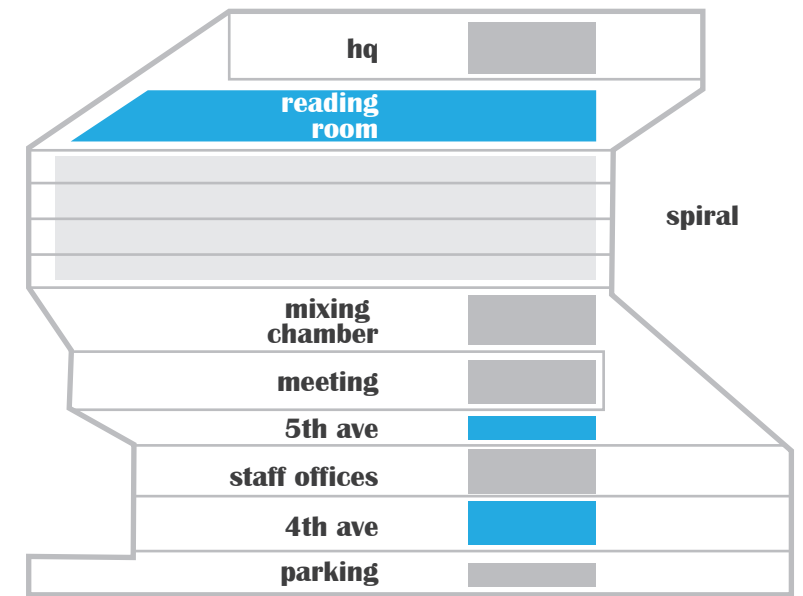

Seattle Public Library: **10th floor**

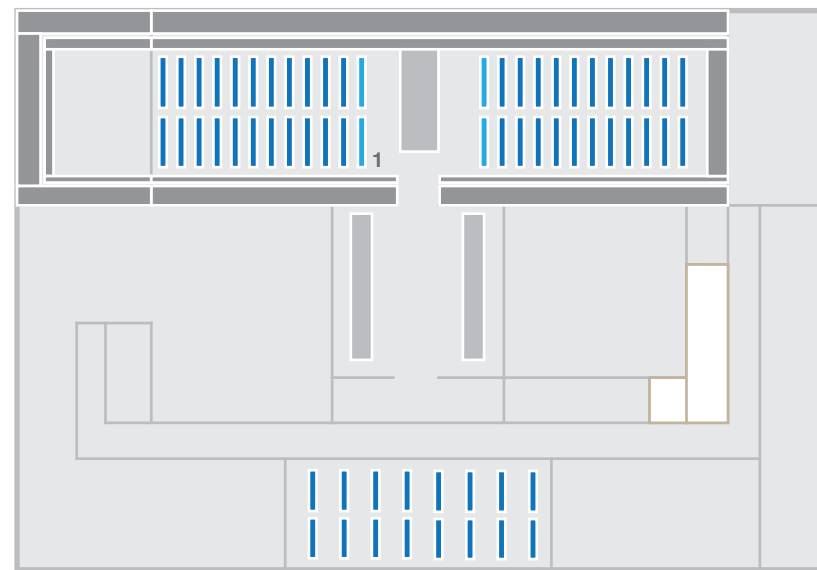

3rd floor

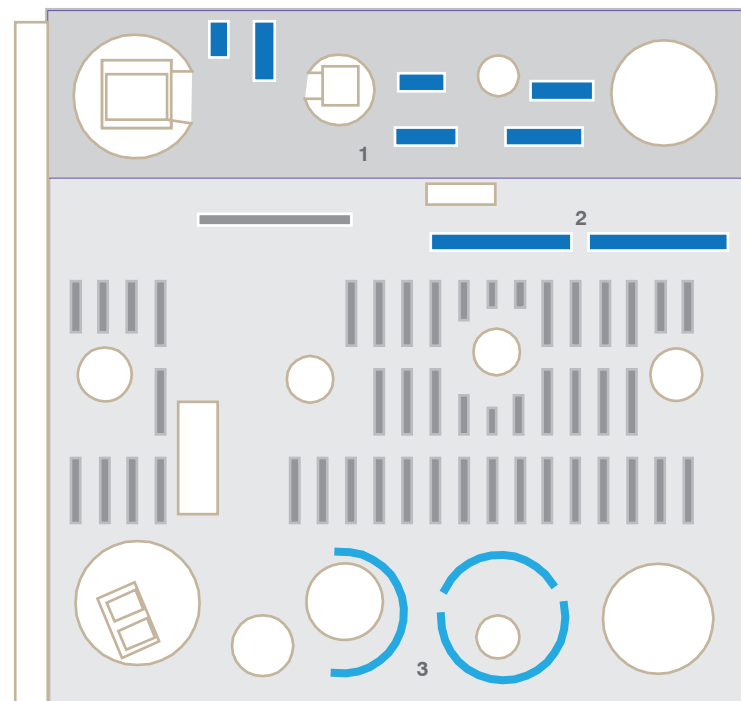

LIBRARY | 3rd + 4th floor

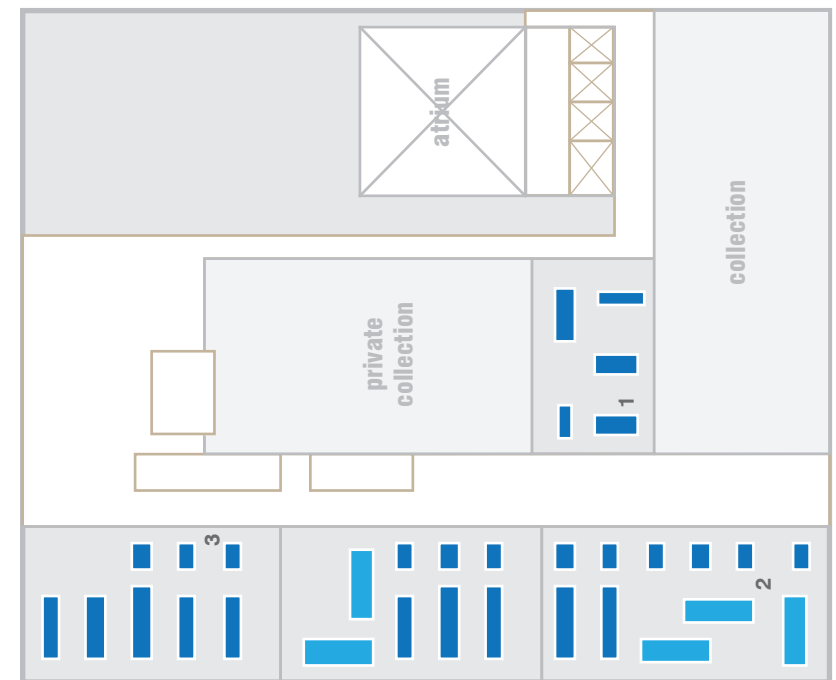

READING ROOM | 10th floor

PRECEDENTS READING ROOM

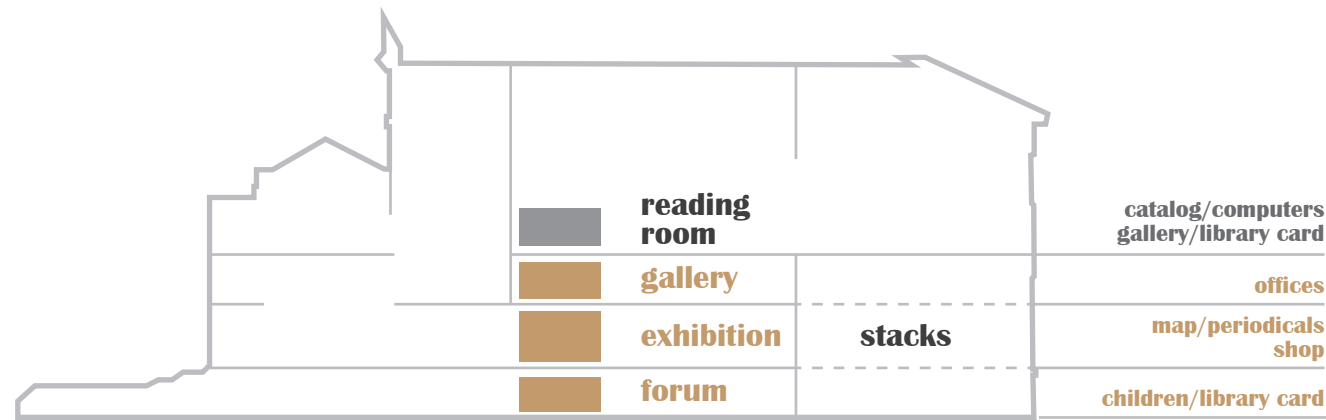

New York Public Library

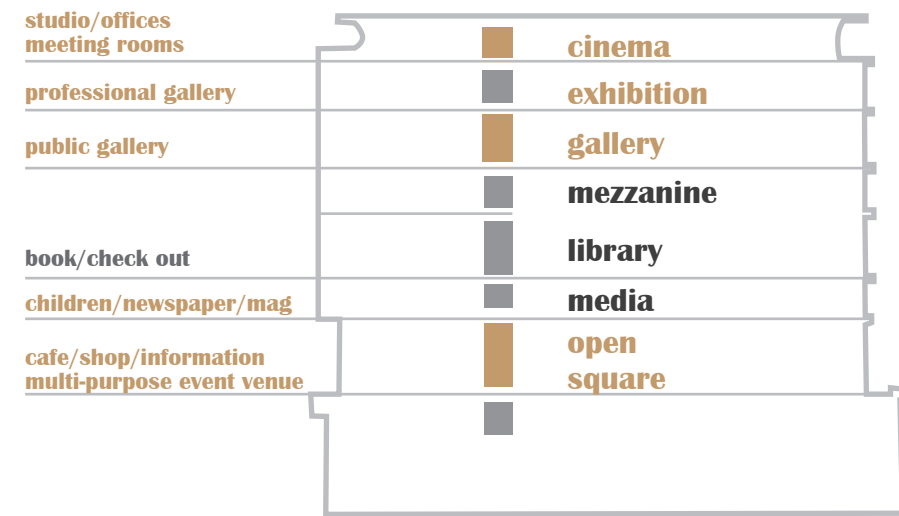

Sendai Mediatheque

children's collection

newspaper/magazine

meeting room/office space

gallery/exhibition

auditorium

cafe/shop/public space

PRECEDENTS COMMUNITY SPACES

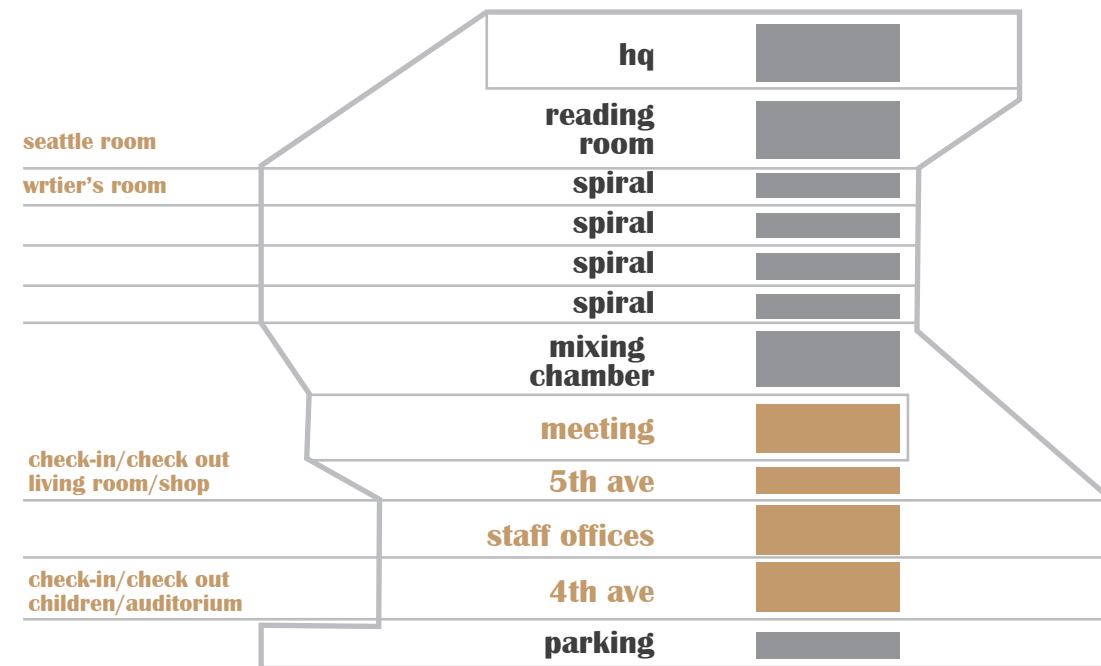

Seattle Public Library

shhhh...

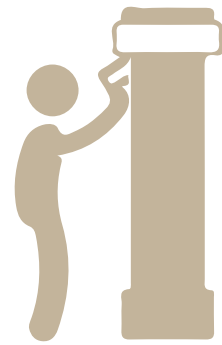

CONVERSATIONS WITH EXPERTS

VISUAL

ACOUSTICS

FLEXIBILITY

ELEMENTS



WHAT DO YOU THINK A PUBLIC LIBRARY SHOULD BE?

first thing people think of when they come to a community, serve as a **PORTAL TO RESOURCES**

a **COLLECTION OF SPACES** that supply people based on their needs

NON-JUDGEMENTAL space for people to explore their interests

a **DESTINATION** for people to visit for public access to information

WHAT ARE SOME CURRENT ISSUES WITH THE LIBRARY?

book stacks are too tall, you can't see the people behind the stacks which creates **SERVICE AND SECURITY** issues

the **BIG WEED** is happening to clean out uncirculated material and there are **NOT ENOUGH COMPUTERS** for public access

the amount of books on shelves and signage are **OVERWHELMING** and hard to differentiate

the amount of **COLLECTION CAN'T BE ACCESSED** by Google search.
 'google can bring you back 100,000 answers, and librarian can bring you back to the right one'
 by Neil Gaiman

CONVERSATIONS WITH EXPERTS

SYRACUSE ONONDAGA PUBLIC LIBRARY
 DOWNTOWN BRANCH LIBRARIANS

WHAT DO YOU THINK A PUBLIC LIBRARY SHOULD BE?

GRADUATE STUDENT:

It is no longer a repository of books,
it is a place to share information

Knowledge of the past is going through
Digital Preservation. Knowledge constantly being
created due to general knowledge transfer.

RELEVANT AND TIMELY INFORMATION IS THE KEY

We should reinvision how we market ourselves...Add tools
INSTEAD OF A PLACE TO ABSORB OR FIND KNOWLEDGE
IT SHOULD BE A PLACE OF CREATION WHICH PUTS
KNOWLEDGE IN PRACTICE

PROFESSOR:

PLATFORM FOR ECONOMIC DEVELOPMENT

Provide Tools for Development to create an employeable community
Adaptable to Community wants and needs

Bad Libraries Building Collections
Good Libraries Build Services
Great Libraries Build Communities

MAKING CONNECTIONS IN COMMUNITY AND OUTSIDE. NOT JUST ACCESSING
OUTSIDE INFORMATION, BUT ALSO FROM EACH OTHER

COMMUNITY RESOURCE FROM EACH OTHER point to people in the direction to find
information

COMMUNITY PROFILE community member or business, club or group can be catalogued and
held in a library.

COMMUNITY SHELF reflect the community in what it creates

HUMAN LIBRARY check out a person to talk to for their expertise and interest in showing a skill

CONVERSATIONS WITH EXPERTS

SCHOOL OF INFORMATION TECHNOLOGY

PROFESSOR / GRADUATE STUDENT

WHAT KIND OF SPACES WOULD YOU LIKE?

VISUAL

no nooks, **VISUALLY OPEN** spaces so librarians can see what's going on

bright spaces with **NATURAL LIGHTING** and less artificial lighting

FLEXIBILITY

there should be **TRANSFORMABLE, MULTI-PURPOSE** spaces for different types of events

flexible spaces with lower shelves and **NO IMPOSING STRUCTURE**

ACOUSTICS

ACOUSTIC VARIATION of zones for quiet reading and zones for activity and conversation

ELEMENTS

shelves on wheels, so they can be **MOBILE**

VISUAL DISPLAY of book covers instead of textual display of book titles

REQUESTS FROM EXPERTS

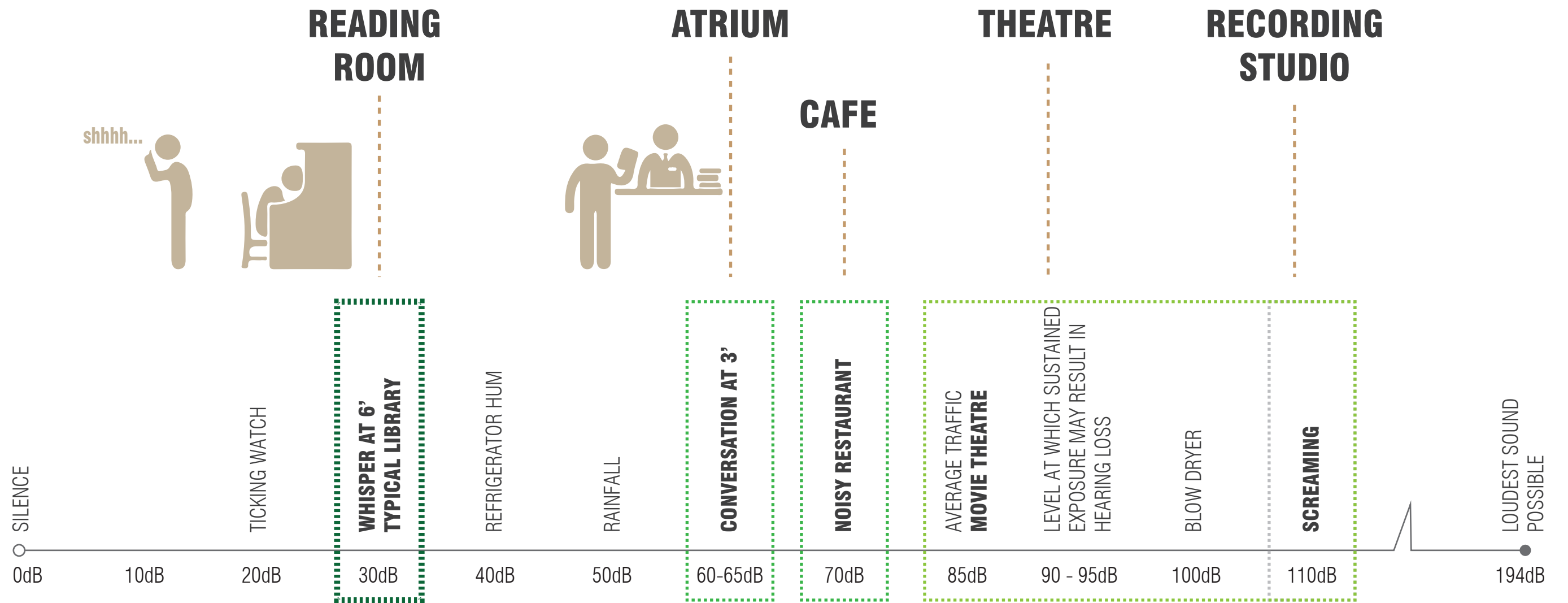

SOUND VARIATIONS

ACOUSTIC VARIATION of zones for quiet reading and zones for activity and conversation

RESPONSES TO REQUESTS SOUND PROMXIMITY

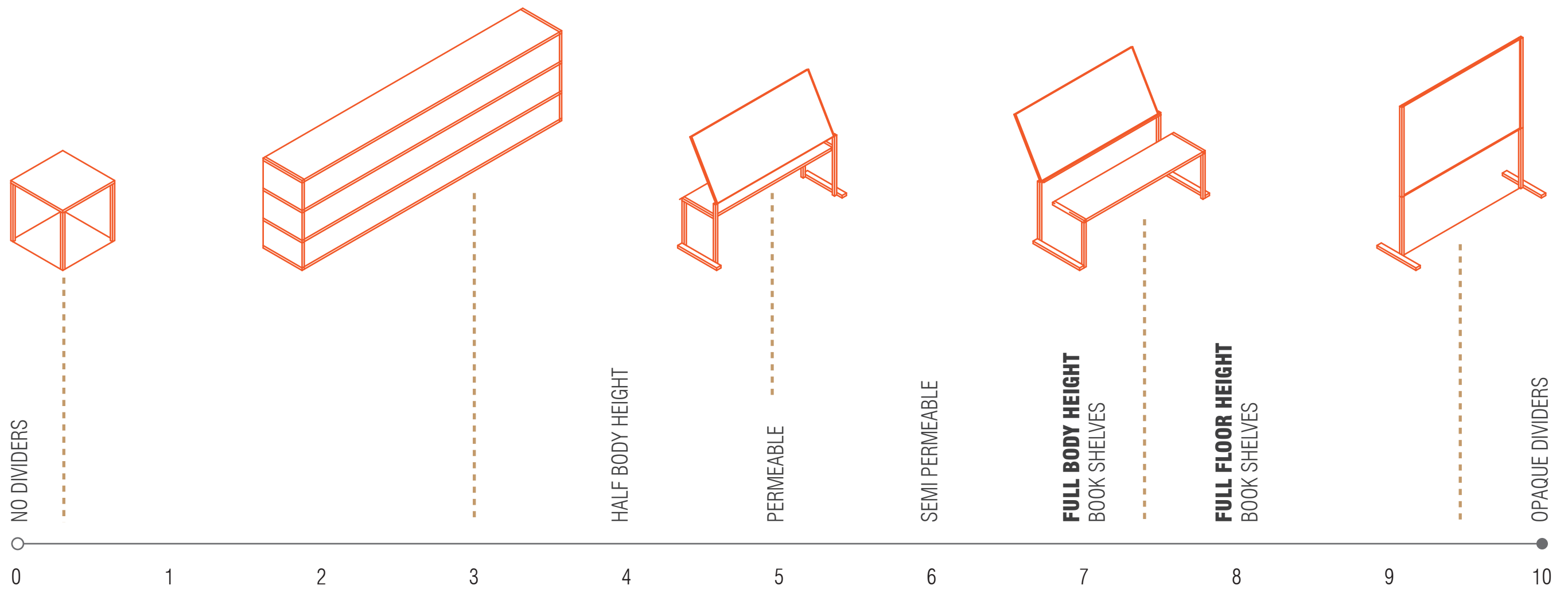

DIVIDERS

no nooks, **VISUALLY OPEN** spaces so librarians can see what's going on
 there should be **TRANSFORMABLE, MULTI-PURPOSE** spaces for different types of events
 flexible spaces with lower shelves and **NO IMPOSING STRUCTURE**

RESPONSES TO REQUESTS VISUAL PROMXIMITY

SOUND LOUNGES

ACOUSTICALLY CONTROLLED
VISUALLY OPEN

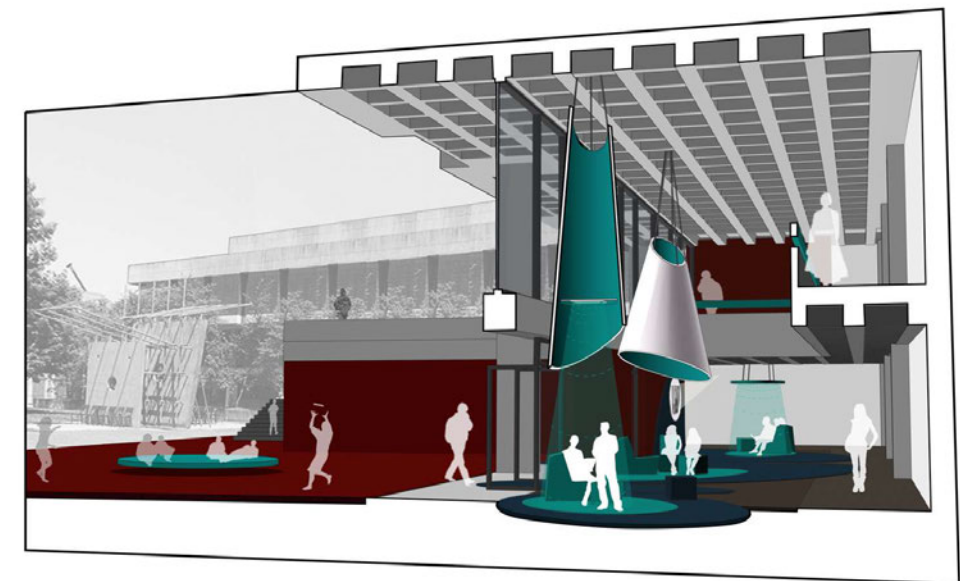
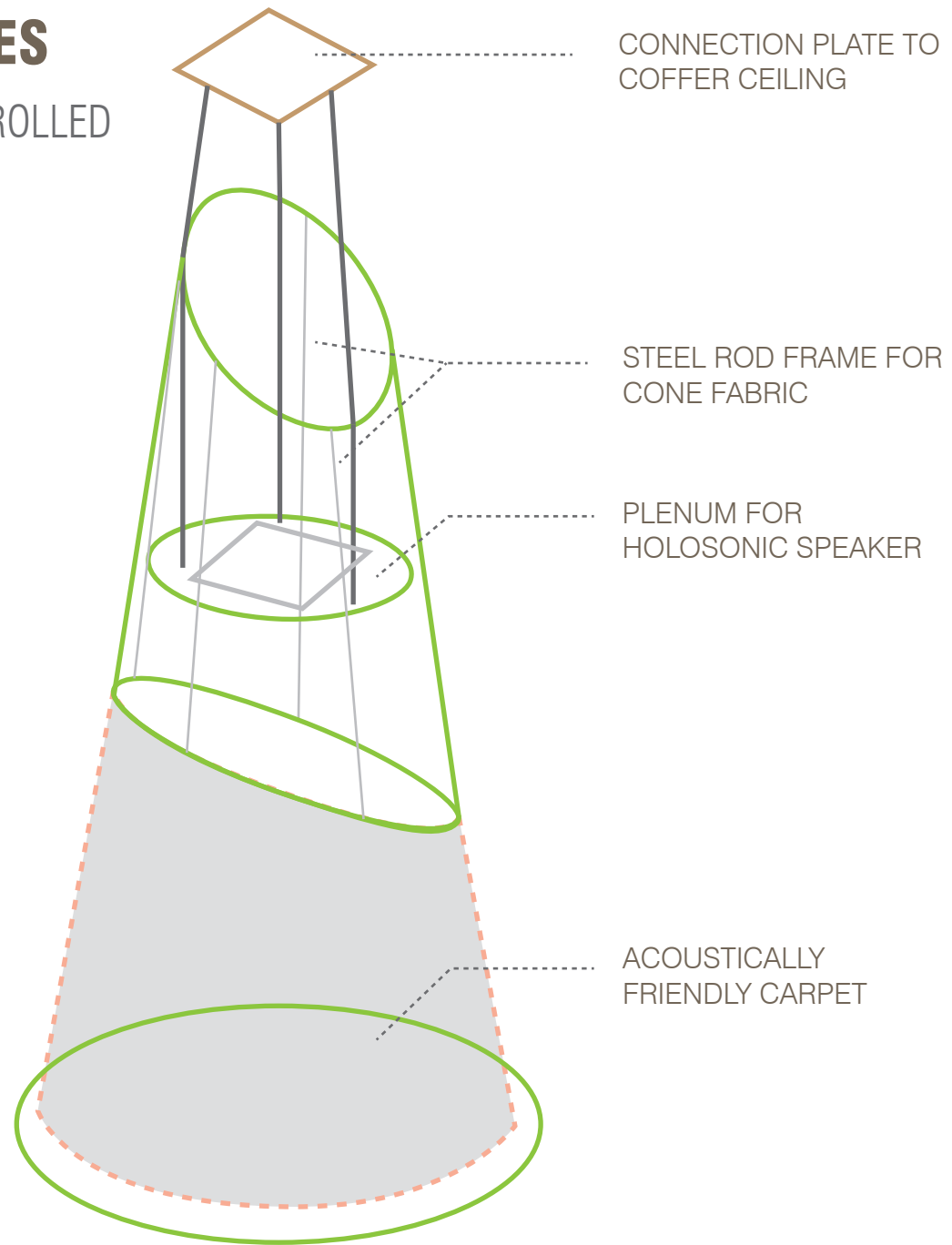

Sound Lounge. Digital image. Architizer. Architizer, n.d. Web. 14 Apr. 2014.

RESPONSES TO REQUESTS VISUAL AND SOUND PROMXIMITY

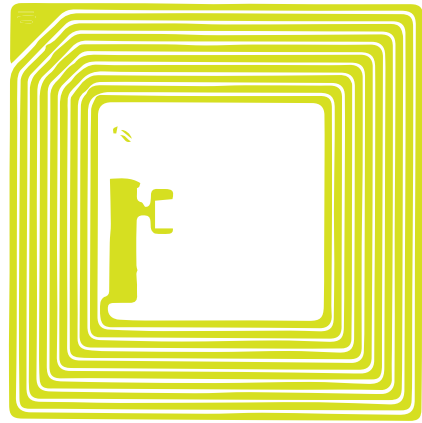

RFID ATTACHED TO THE BOOK



READ RFID IDENTIFICATION SYSTEM TO TRACK LOCATION OF BOOKS

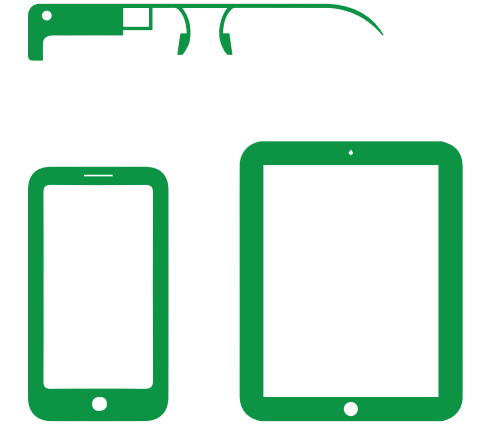

GPS SYSTEM TRACKING SYSTEM OF LIBRARY 3D MODEL TO INDICATE LOCATION

INTERGRATE THE EXISTING **RFID TAG WITH GPS TRACKING SYSTEM** FOR BOOKS



RESPONSES TO REQUESTS MOBILITY

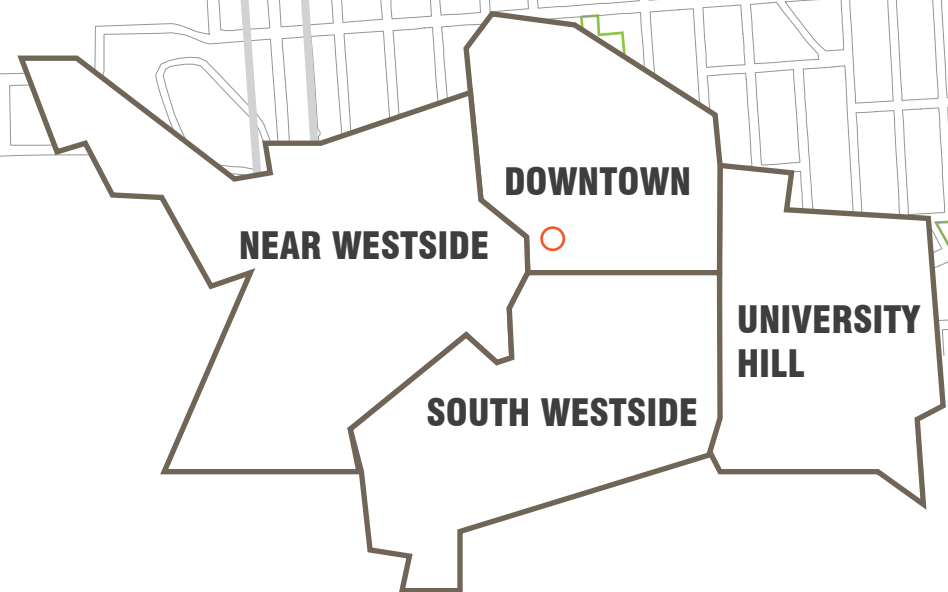
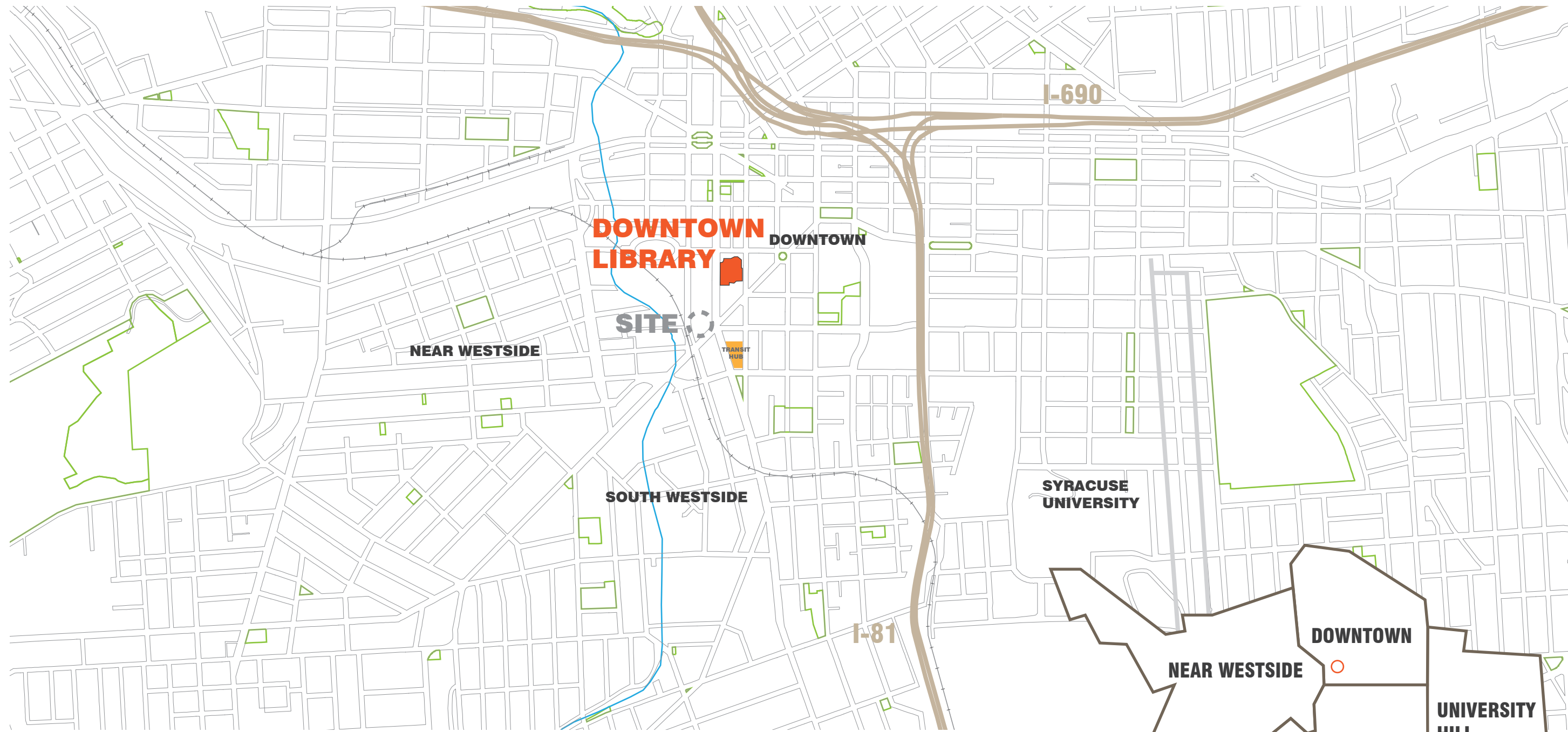

ONONDAGA PUBLIC LIBRARY DOWNTOWN

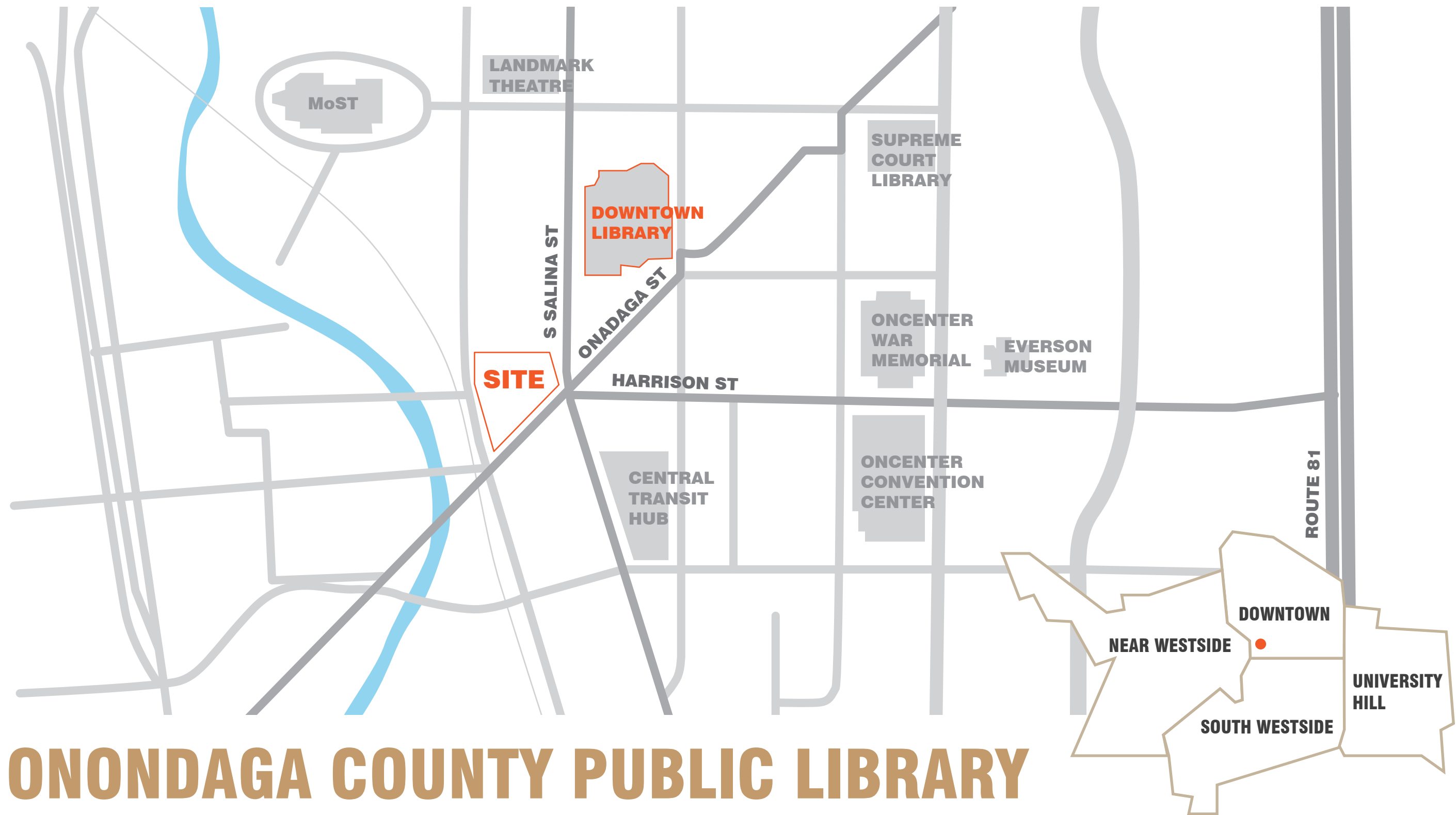

ONONDAGA COUNTY PUBLIC LIBRARY

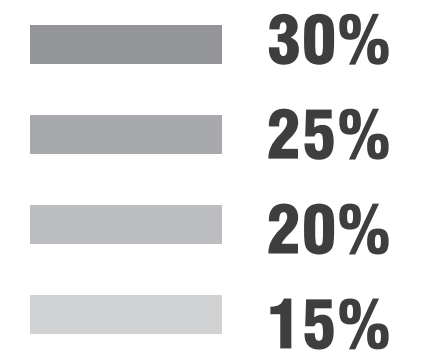
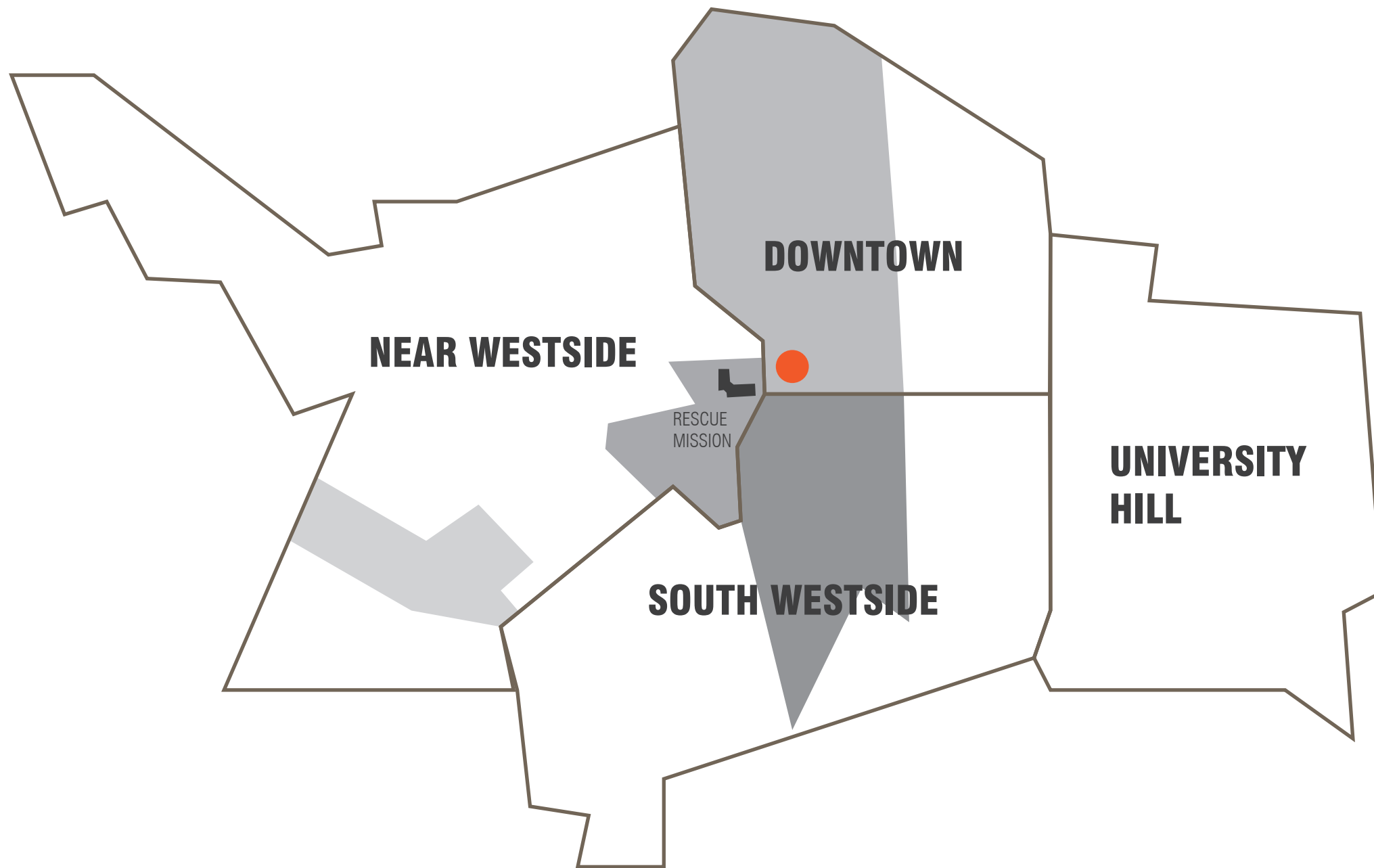

PUBLIC SERVICE

- JOB RESOURCES
- TAX FORMS
- GRANT APPLICATION

READING/STUDY

- COMPUTER CLASSES
- INTERNET ACCESS

BOOKS

SITE DEMOGRAPHICS UNEMPLOYMENT



L5 Administration Offices
 Genealogy Collection [Books/Spaces]
 3 Meeting Rooms [By Reservation]
 Open Desks [Reading/Laptop]



L4 Info Counter [General Questions]
 Children Collection [Books/Spaces]
 Teen Collection [Books]
 ESL [Tutoring/Books]
 Star Center [Blind Readers]
 Open Desks [Reading/Laptop]



L3 Info Counter [General Questions]
 Office Space [Librarian]
 Telephone Reference Room
 Public Restrooms
 Stacks
 Open Desks [Reading/Laptop]
 24 Public Computer [1hr/session 2 session/day]
 Foundation Application
 Job Resources



L2 Info Counter [General Questions] 2 Librarians
 Service Counter [Library Cards, Book Reserve] 2 Librarians
 Check Out Counter 2 Librarians
 Circulating Books
 DVD/CD ROM
 2 Catalogue Computer [Standing]
 6 Public Computers [15 min/session 2 session/day] [Standing]
 Open Desks [Conversation/Reading/Laptops]
 Tax Return Forms



L1 Auditorium [Weekly Movie/Documentary Showing]

MAKING CONNECTIONS IN COMMUNITY AND OUTSIDE. NOT JUST ACCESSING OUTSIDE INFORMATION, BUT ALSO FROM EACH OTHER

COMMUNITY RESOURCE FROM EACH OTHER point to people in the direction to find information
COMMUNITY PROFILE community business, club or group can be catalogued and held in a library.
COMMUNITY SHELF reflect the community in what it creates
HUMAN LIBRARY check out a person to talk to for their expertise and interest in showing a skill

ADMINISTRATION



SUPPORT



BOOKS



READING/STUDY



PUBLIC SERVICE



COLLECTIVE



ADDITIONAL PROGRAM

COLLECTIVE SPACE

cafe style tables [discussion] HUMAN LIBRARY

MEETING ROOMS

large group meeting room [20-30 people]
 small group meeting space [5-15 people]

MULTIPURPOSE ROOM

CLASSROOM

computer classrooms
 language/
 MOOC classroom

WORKSHOP SPACES MAKERSPACES [learn and create]

3D printers, lazer printers

CARSHARE PROGRAM

ONPL EXISTING PROGRAM

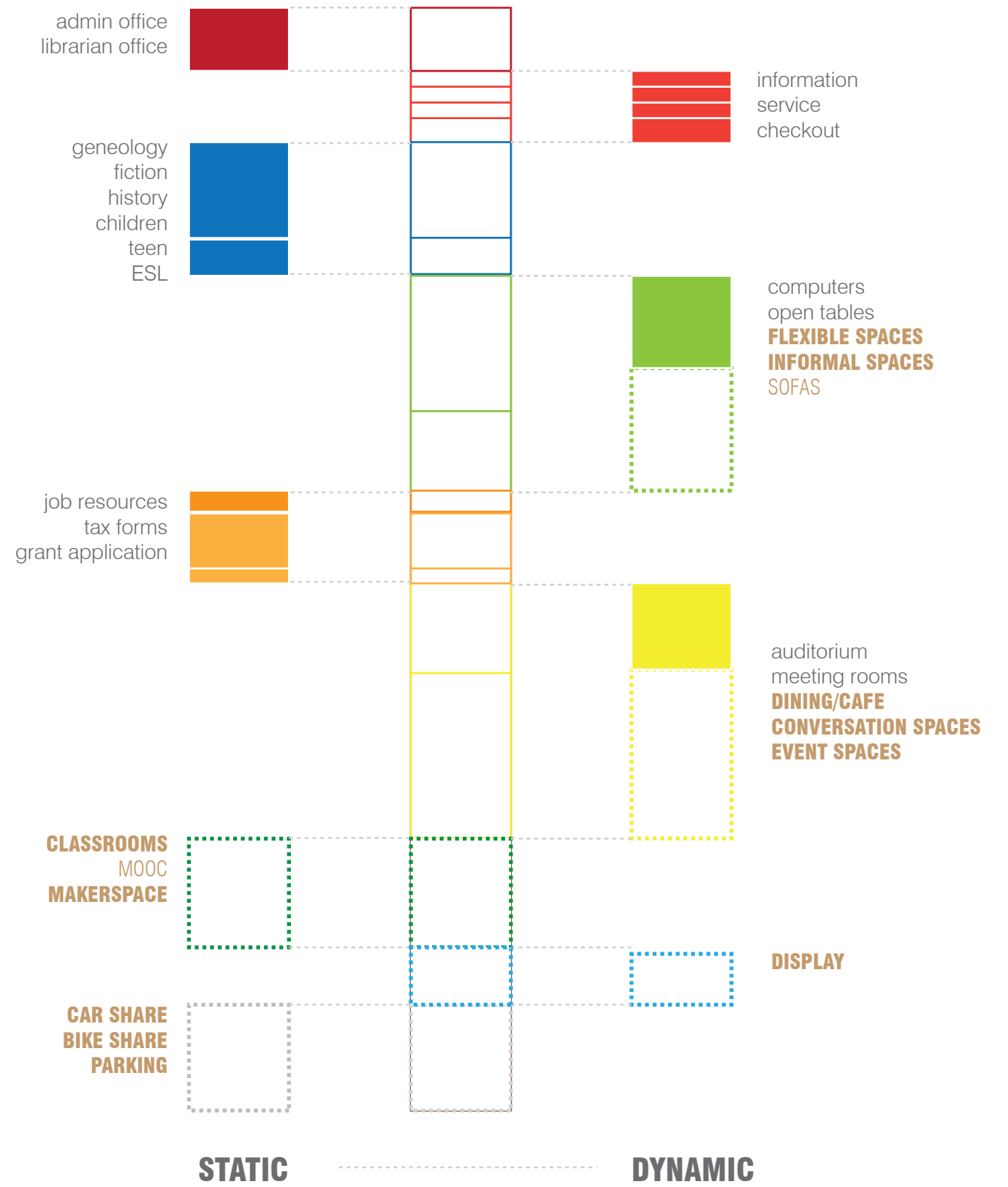
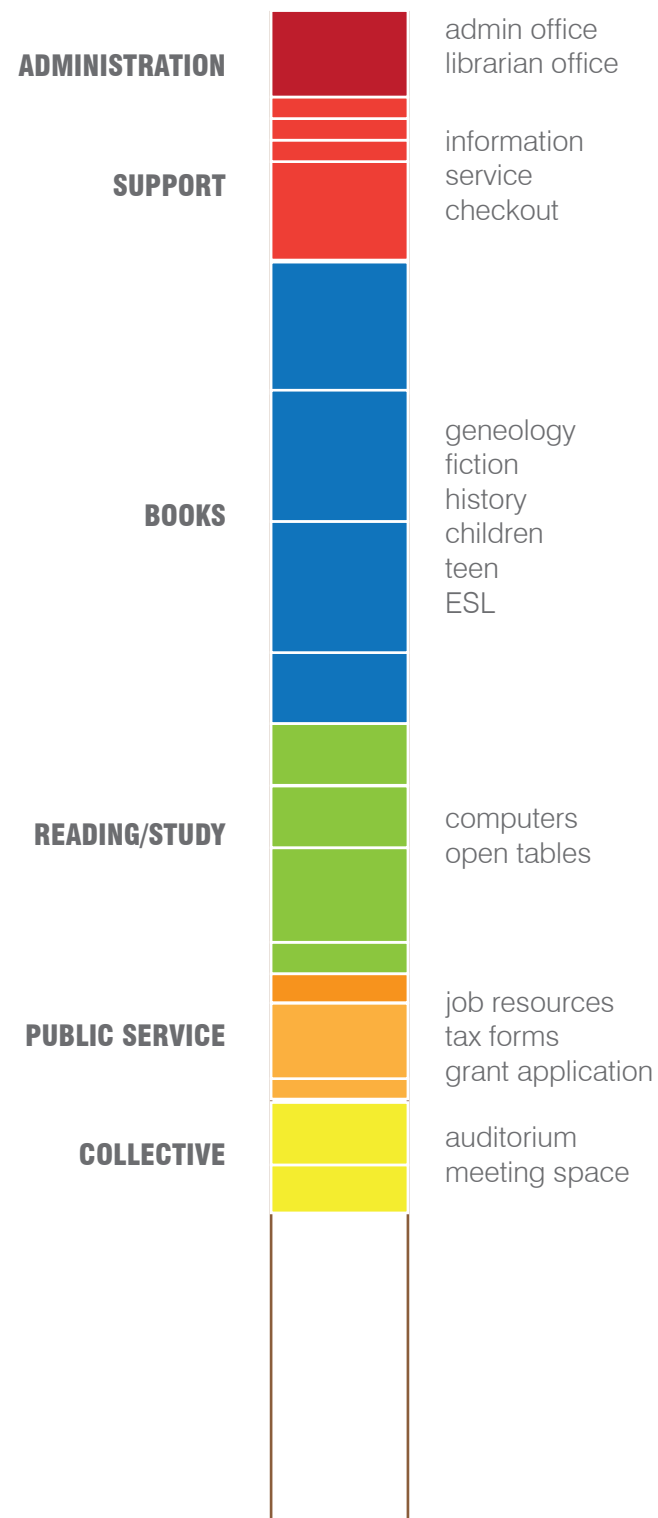
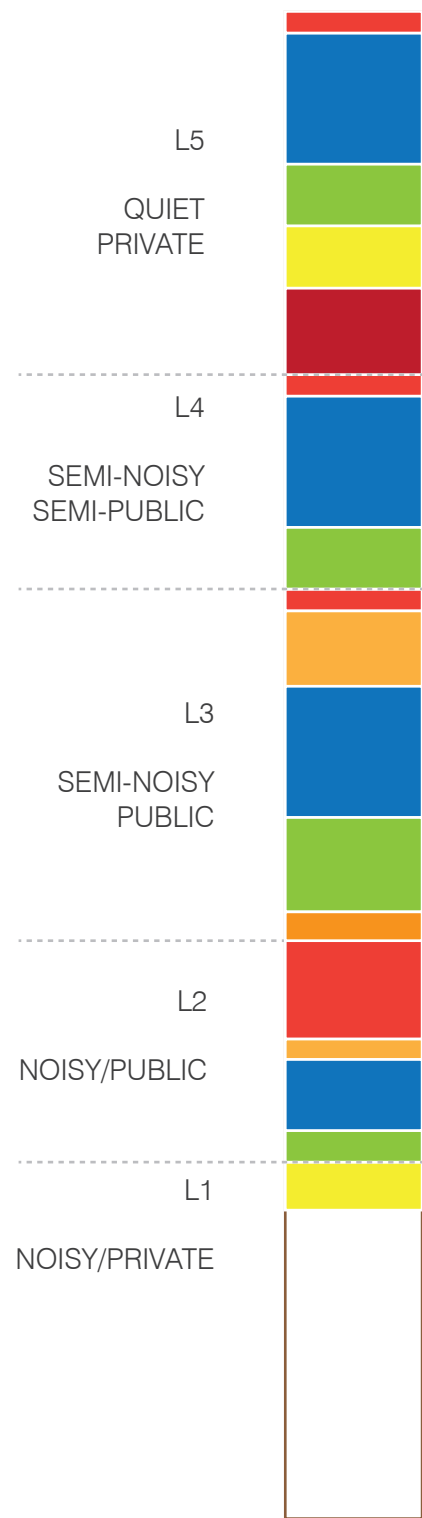

ONPL PROPOSED PROGRAM

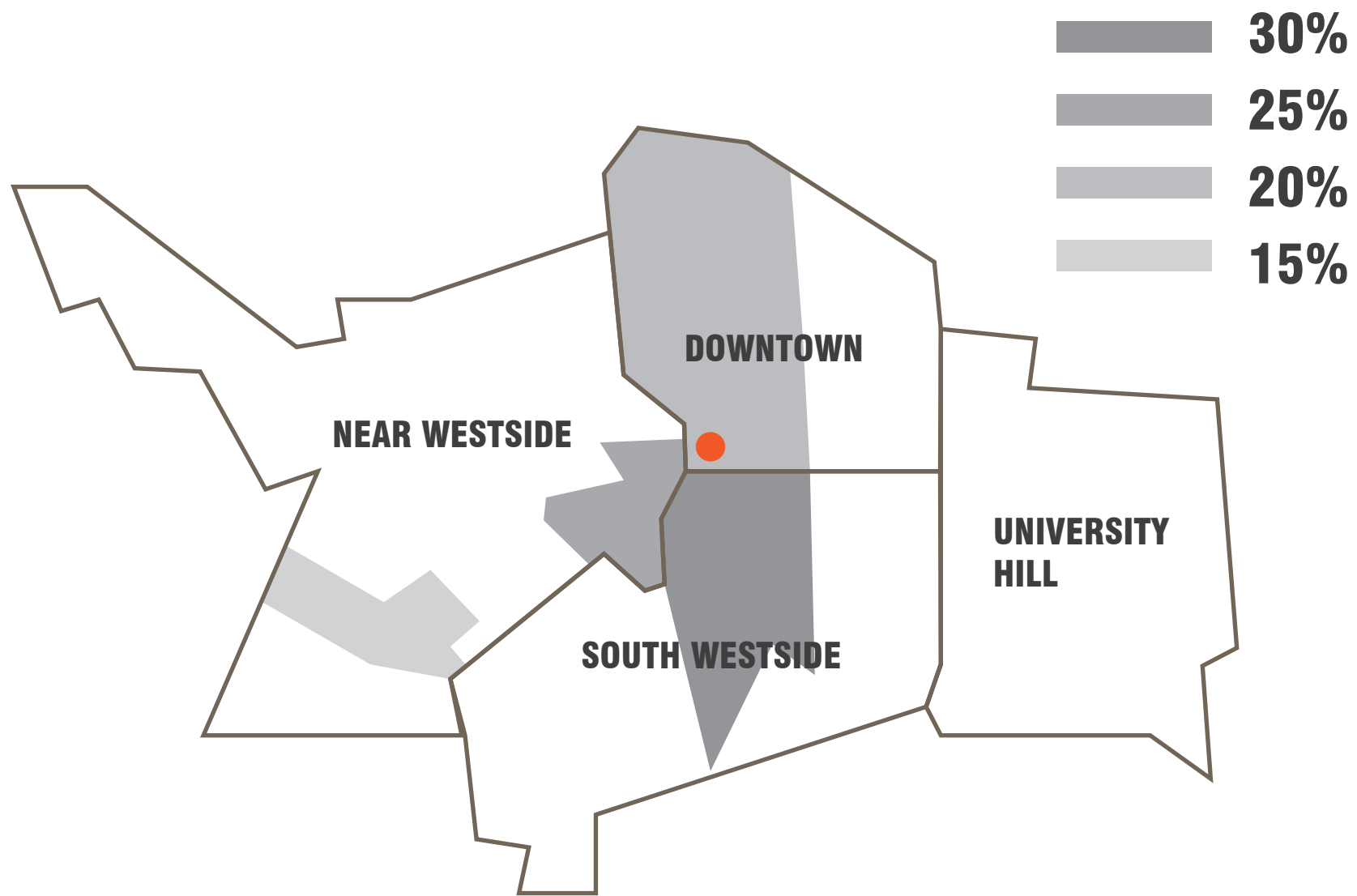

- LEARN** (Green dashed box) **CLASSROOMS**
MASSIVE OPEN ONLINE COURSES
- CREATE** (Green dashed box) **MAKERSPACE**
3D PRINTER/ LAZER CUTTER AND VARIOUS TOOLS FOR CREATION
- EXCHANGE** (Blue dashed box) **DISPLAY**
COMMUNITY RESOURCES AND OPPORTUNITIES FOR COLLABORATION
- SHARE** (Grey dashed box) **CAR SHARE**
BIKE SHARE
SUSTAINABLE RESOURCE FOR COMMUNITY GROWTH

PROGRAM ADDITIONS FOR UNEMPLOYED DEMOPGRAHICS

- CLASSROOMS** (Green dashed box)
MOOC
MAKERSPACE (Green dashed box)
- DISPLAY** (Blue dashed box)
- CAR SHARE** (Grey dashed box)
BIKE SHARE (Grey dashed box)

PUBLIC SERVICE

- (Orange bar)
- JOB RESOURCES
- TAX FORMS
- GRANT APPLICATION

READING/STUDY

- (Green bar)
- COMPUTER CLASSES
- INTERNET ACCESS

SITE DEMOGRAPHICS UNEMPLOYMENT

2,700 DOWNTOWN POPULATION

AGE OF DOWNTOWN RESIDENT'S IS 30.1 YEARS

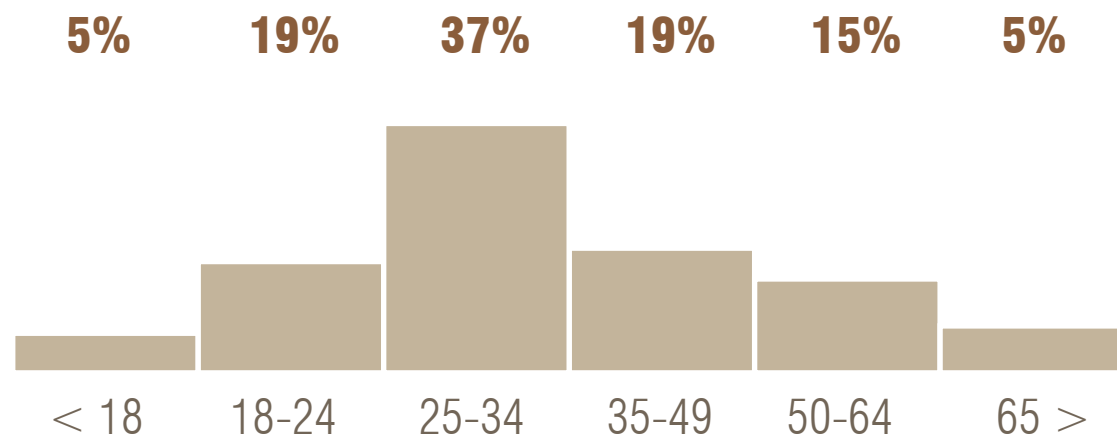

60% OF RESIDENTS BETWEEN 25 AND 34 YEARS OF AGE HAVE A **BACHELOR'S DEGREE OR HIGHER**

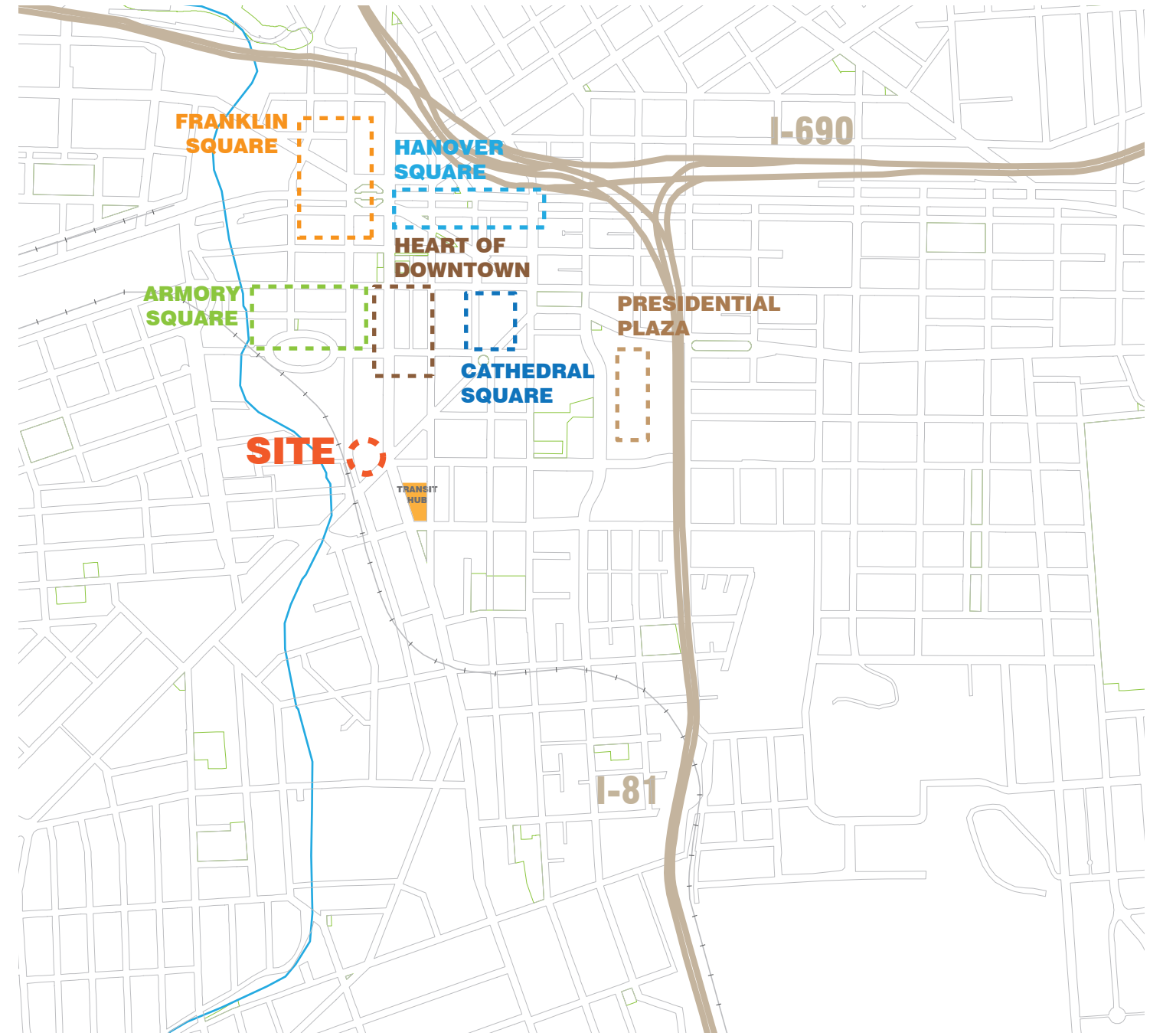

SITE DOWNTOWN RESIDENTIAL GROWTH



EXISTING

ADDITION

ADDITION

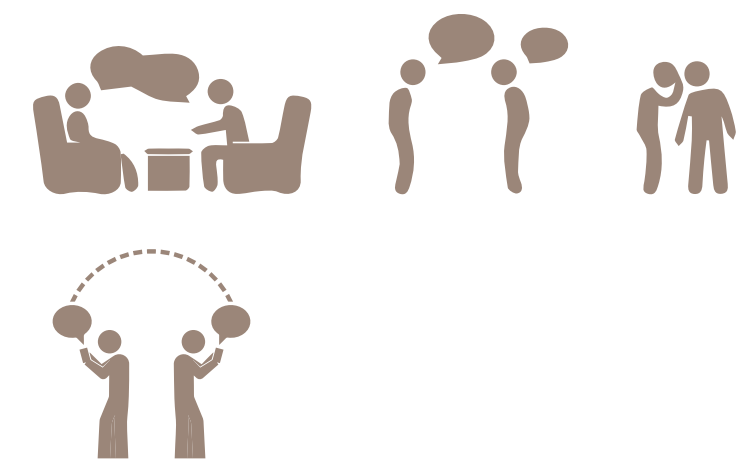

computers
open tables
INFORMAL SPACES
SOFAS

PATRON TO TECHNOLOGY

auditorium
meeting room
DINING/CAFE
CONVERSATION SPACES
EVENT SPACES

PATRON TO PATRON

DISPLAY

CLASSROOMS
MOOC
MAKERSPACE

CAR SHARE
BIKE SHARE
PARKING

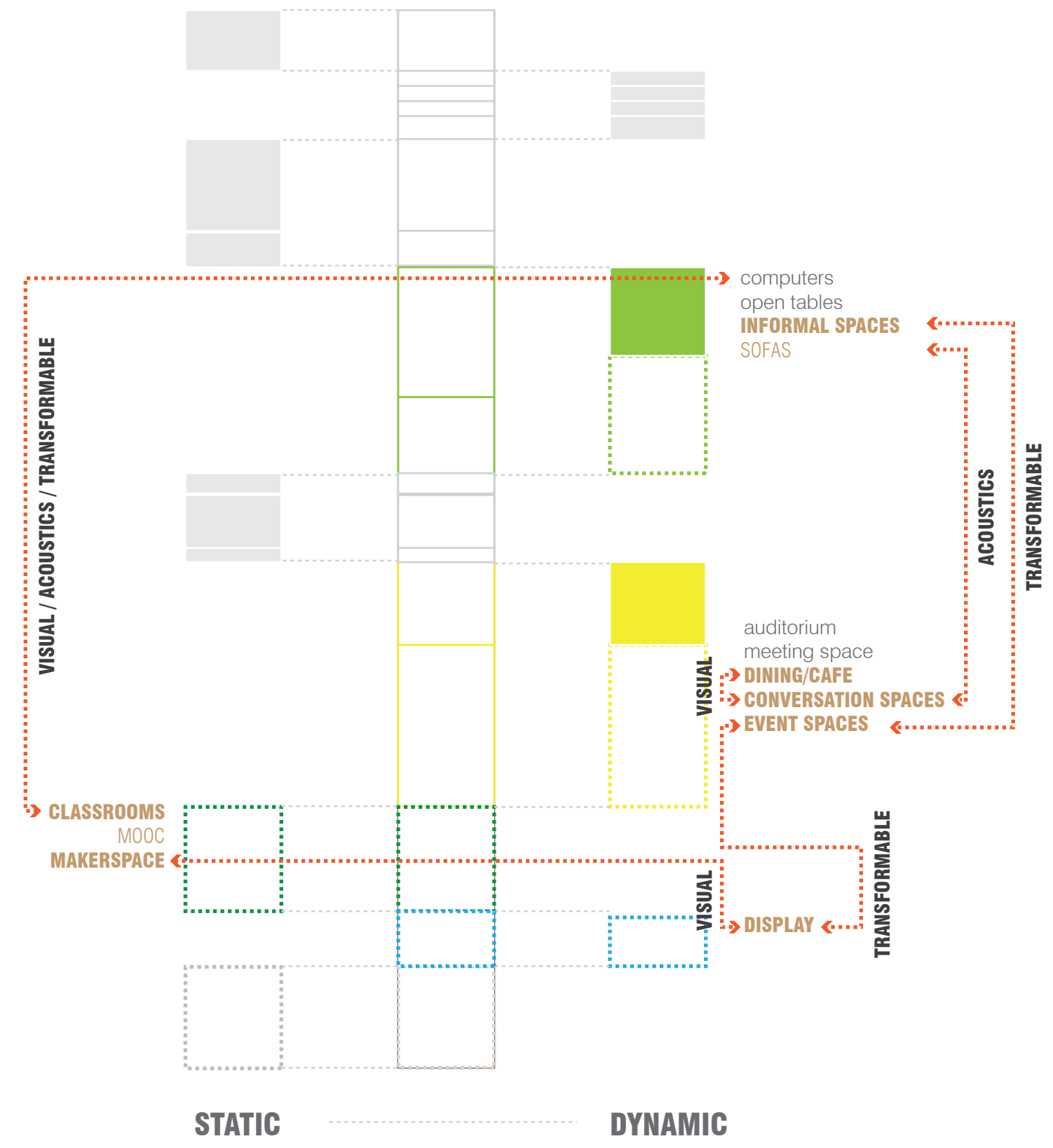

ONPL PROPOSED PROGRAM

SURROUNDING:

Close to Museum of Science and Technology, Landmark Theatre, Everson Museum of Art, the Oncenter Convention Center and Memorial.



SITE PROXIMITY TO DOWNTOWN ATTRACTIONS



SITE SYRACUSE DOWNTOWN

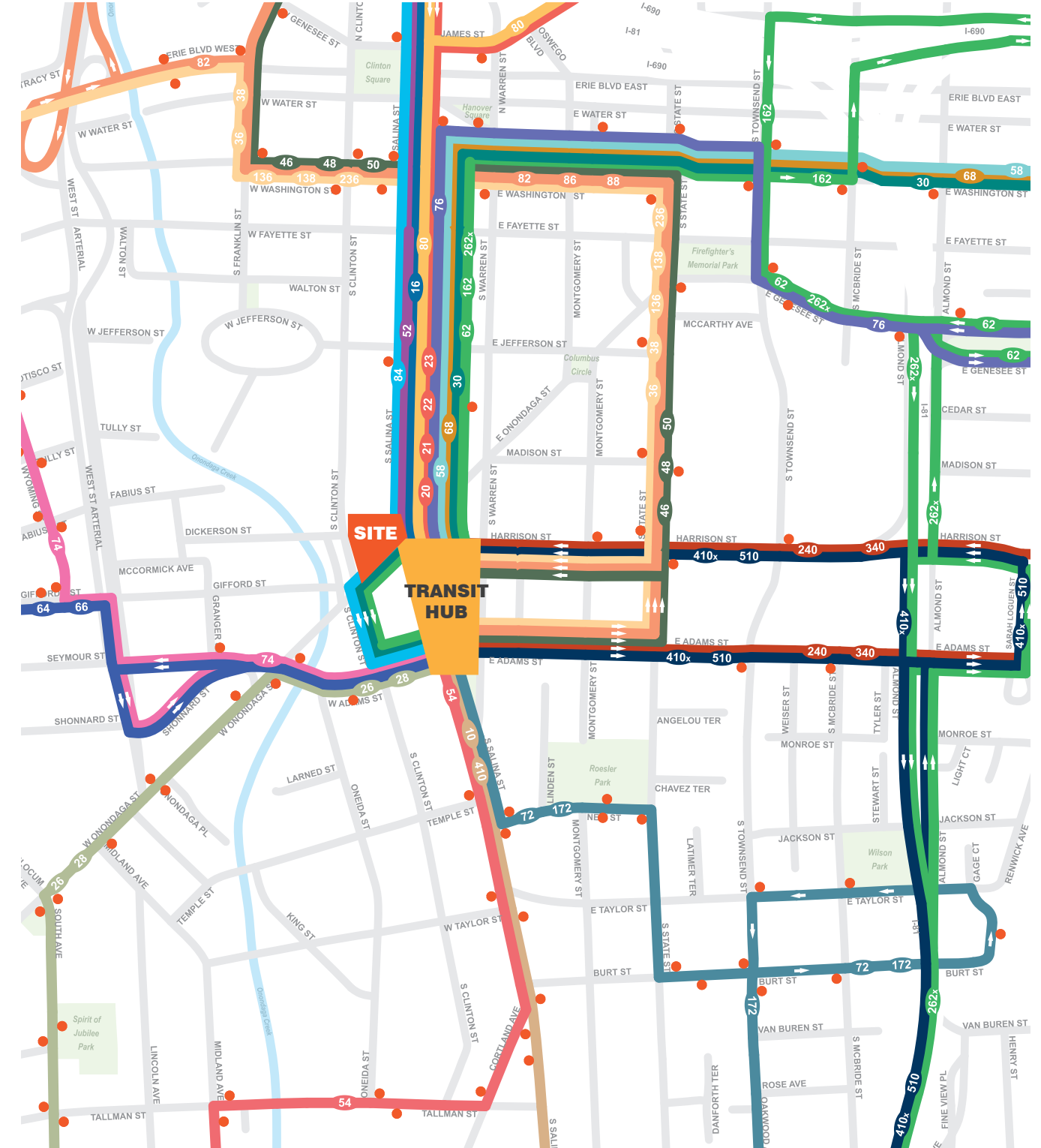
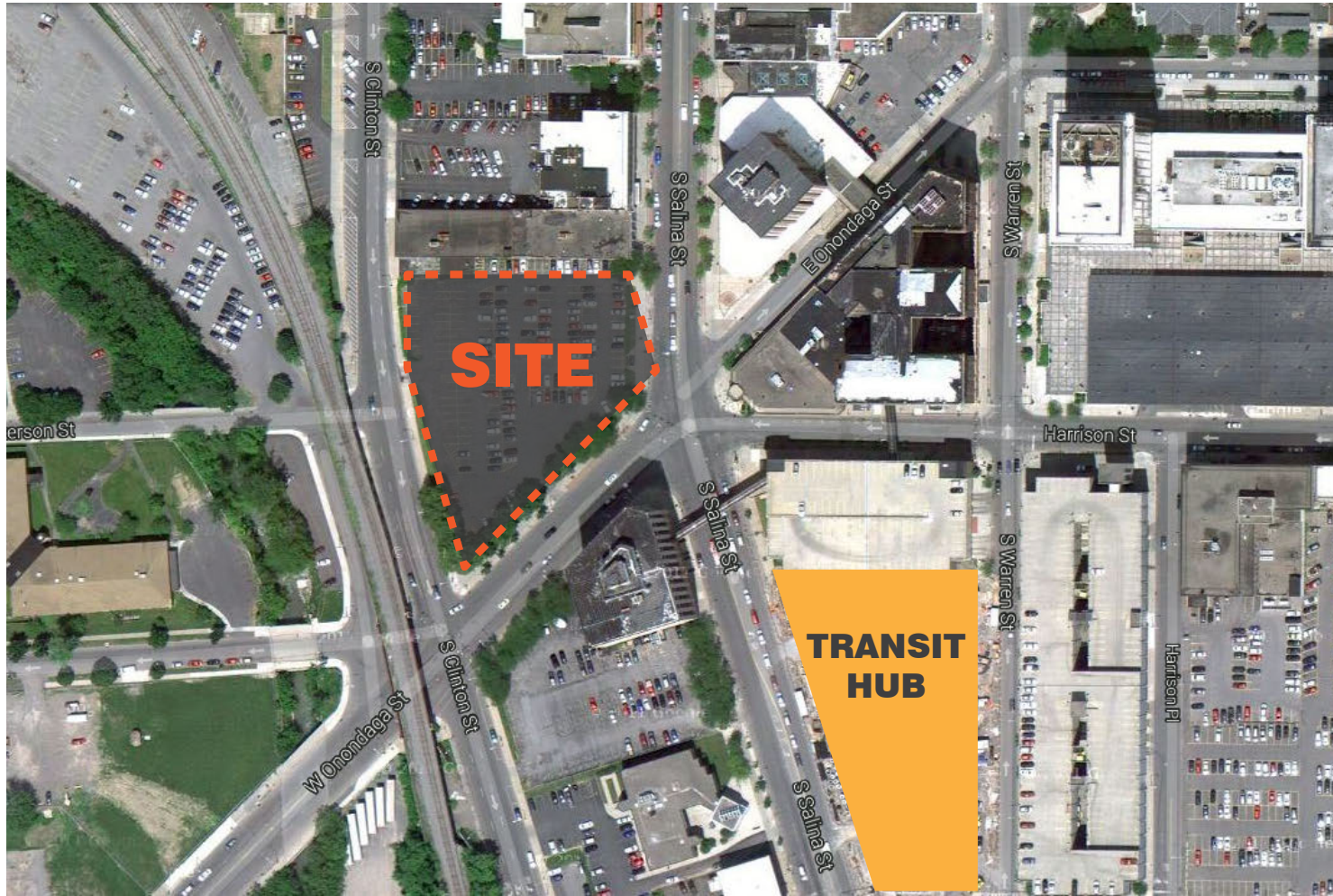

- | | | | |
|--------------------------------|---|-----------------------------------|--------------------------------|
| 10 South Salina | 36 West Genesee - Camillus Commons | 58 Parkhill | 76 East Genesee - Salt Springs |
| 410 Nedrow | 38 Auburn - Elbridge | 62 Fayetteville | 80 Grant Boulevard |
| 16 North Salina | 136 Camillus | 162 Manlius via 690 - Widewaters | 82 Baldwinsville |
| 20 James - Lamson | 138 Auburn - Taunton | 262x Manlius Express via 481 | 86 Henry Clay |
| 21 James - Sunnycrest | 236 Auburn | 64 West Onondaga - Western Lights | 88 North Syracuse |
| 22 James - Route 298 | 46 Liverpool - Route 57 - Great Northern Mall | 66 Grand Avenue | 240 SU - Nob Hill |
| 23 James - East Syracuse | 48 Liverpool - Morgan | 68 East Fayette - Erie Boulevard | 340 SU - Drumlins |
| 26 South Avenue | 50 Destiny USA via I-81 | 72 Townsend | 410x Nedrow Express |
| 28 South Avenue - Valley Drive | 52 Court Street | 172 East Colvin | 510 Tully |
| 30 SU - Westcott | 54 Midland | 74 Solvay | |

SITE TRANSPORTATION

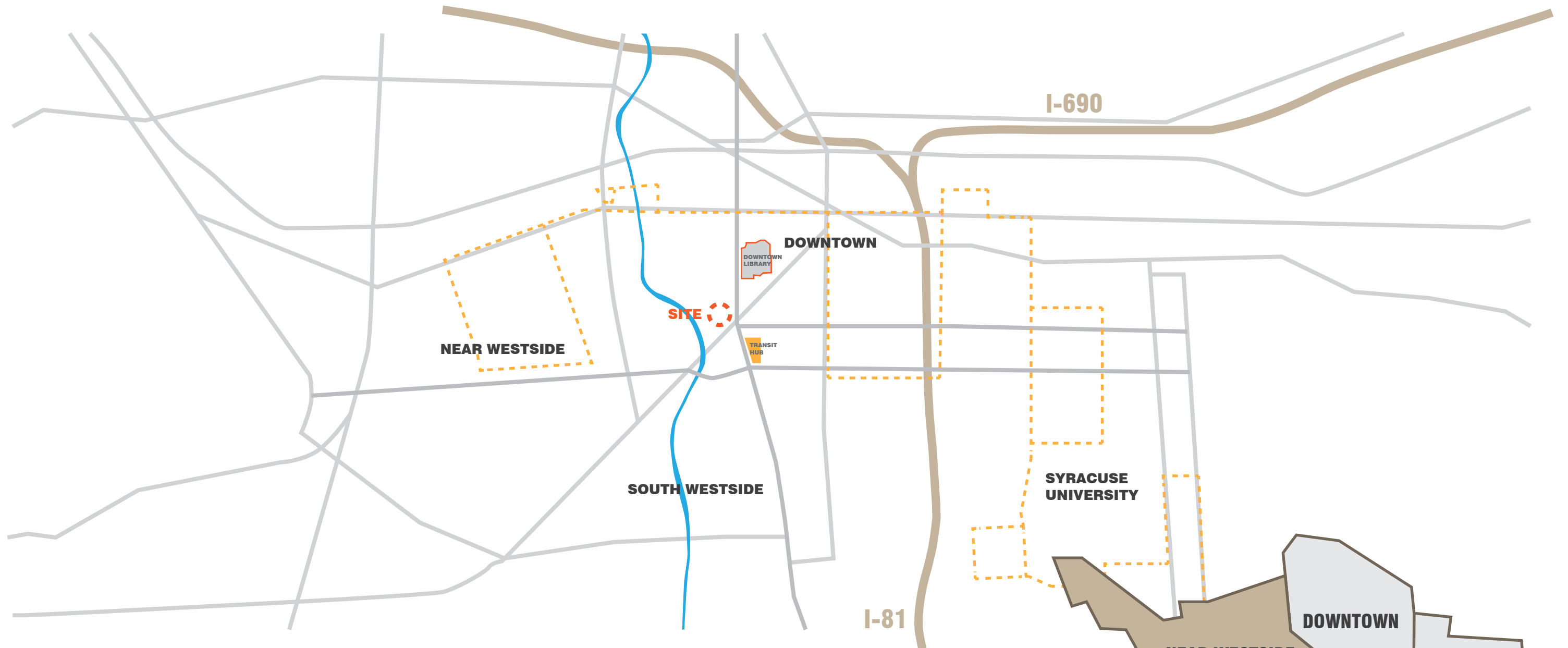

SITE SYRACUSE DOWNTOWN

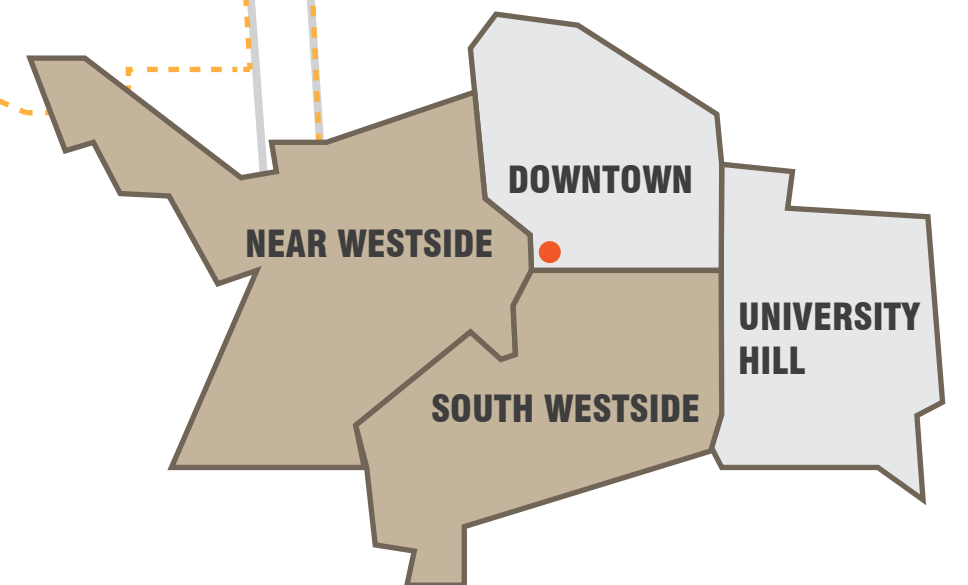



TRANSPORTATION:

On a major intersection between three main road in downtown Syracuse. Next to the central transite hub, the location will be easily accessible by residents of Syracuse.

SITE TRANSPORTATION

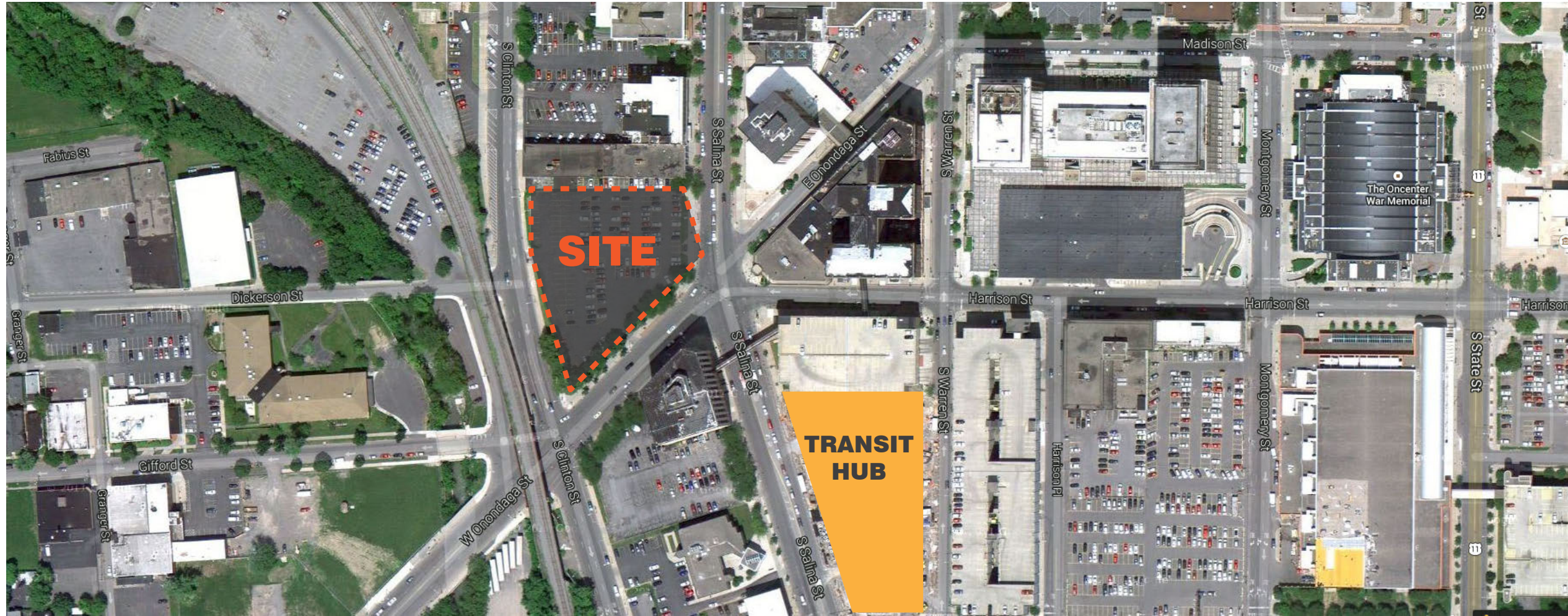

PROPOSED SITE

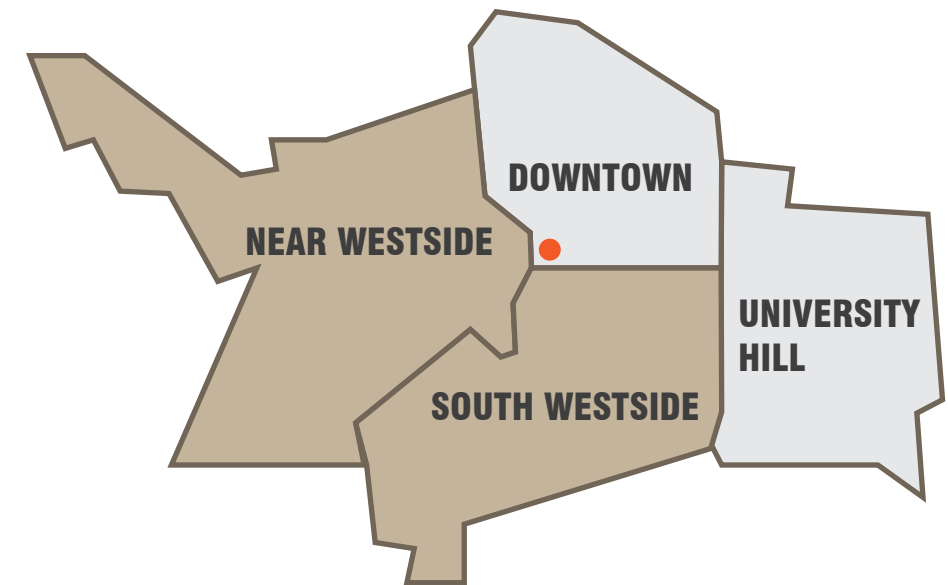

"Be Downtown Syracuse." Downtown Committee of Syracuse. 1 Apr. 2014

<<http://www.downtownsyracuse.com/>>.

"Getting started with Twitter." Twitter Help Center. Twitter. 15 Apr. 2014

<<https://support.twitter.com/articles/215585-getting-started-with-twitter>>.

"History of The New York Public Library." New York Public Library. New York Public Library. 07 Apr. 2014

<<http://www.nypl.org/help/about-nypl/history>>.

"It's A Noisy World We Live In." Home Page. American Tinnitus Association. 20 Apr. 2014

<<http://www.ata.org/for-patients/how-loud-too-loud>>.

Murphy, Kevin. "The challenges facing academic libraries in the 21st century." Melville House Books. 7 June 2012. 5 Mar. 2014

<<http://www.mhpbooks.com/the-challenges-facing-academic-libraries-in-the-21st-century/>>.

"Near Westside neighborhood in Syracuse, New York." Near Westside neighborhood in Syracuse, New York (NY), 13202. 5 Apr. 2014

<<http://www.city-data.com/neighborhood/Near-Westside-Syracuse-NY.html>>.

"Occupational Noise Exposure." Safety and Health Topics. Occupational Safety & Health Administration. 20 Apr. 2014

<<https://www.osha.gov/SLTC/noisehearingconservation/index.html>>.

United States. Office of Education. Public libraries in the United States of America; their history, condition, and management. Vol. I. Special report, Department of the Interior, Bureau of Education. Washington: Govt. print. off., 1876.

Vinjamuri, David. "Why Public Libraries Matter: And How They Can Do More." Forbes. 16 Jan. 2013. Forbes Magazine. 4 Mar. 2014

<<http://www.forbes.com/sites/davidvinjamuri/2013/01/16/why-public-libraries-matter-and-how-they-can-do-more/>>.

Waller, Vivienne, and Ian McShane. "Analysing the challenges for large public libraries in the twenty-first century: A case study of the State Library of Victoria in Australia." First Monday. 1 Dec. 2008. Peer Review Journal of the Internet. 10 Mar. 2014

<<http://firstmonday.org/article/view/2155/2060#p2>>.

BIBLIOGRAPHY

PART II: Design

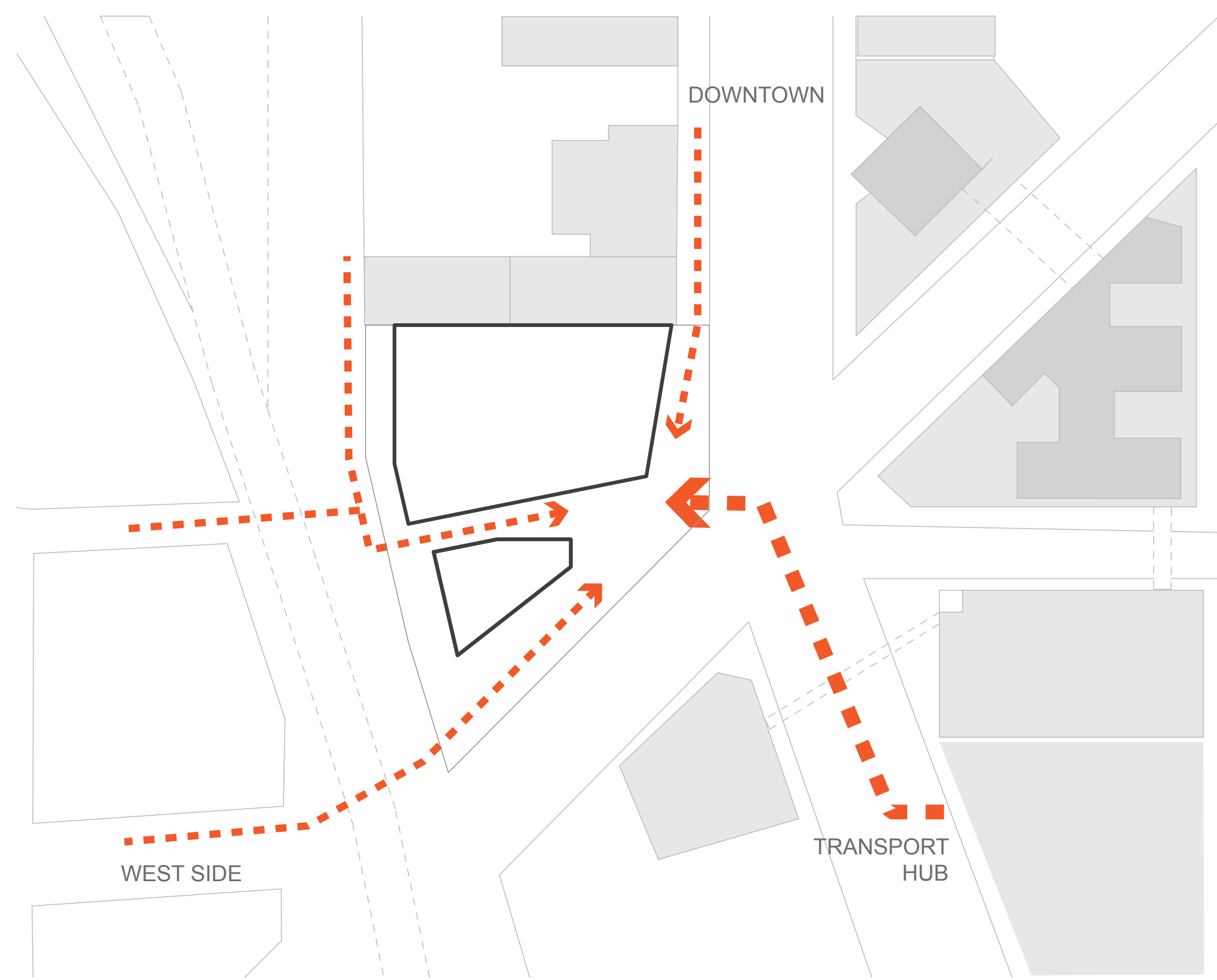

PEDESTRIAN CIRCULATION

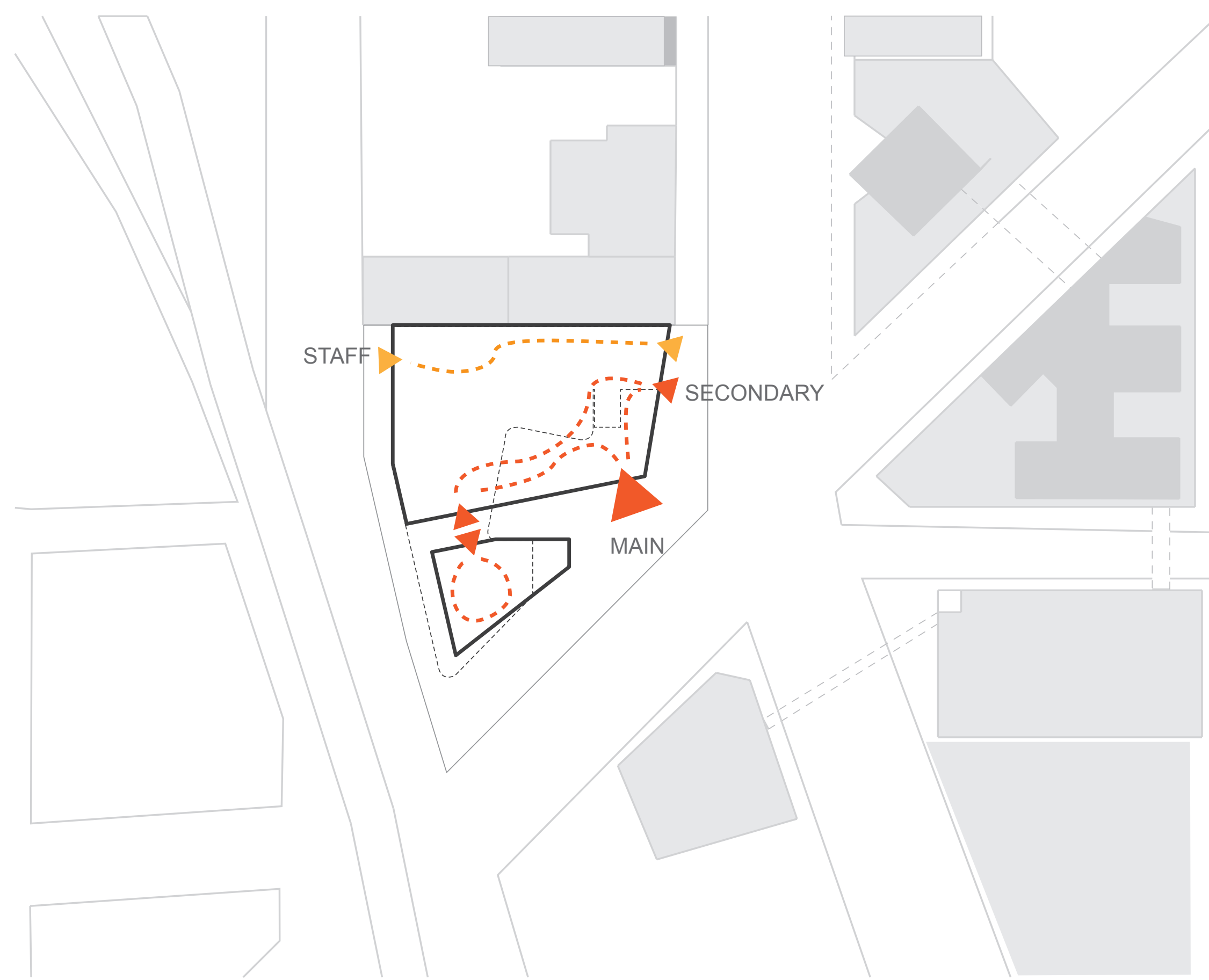

GROUND LEVEL ENTRANCES

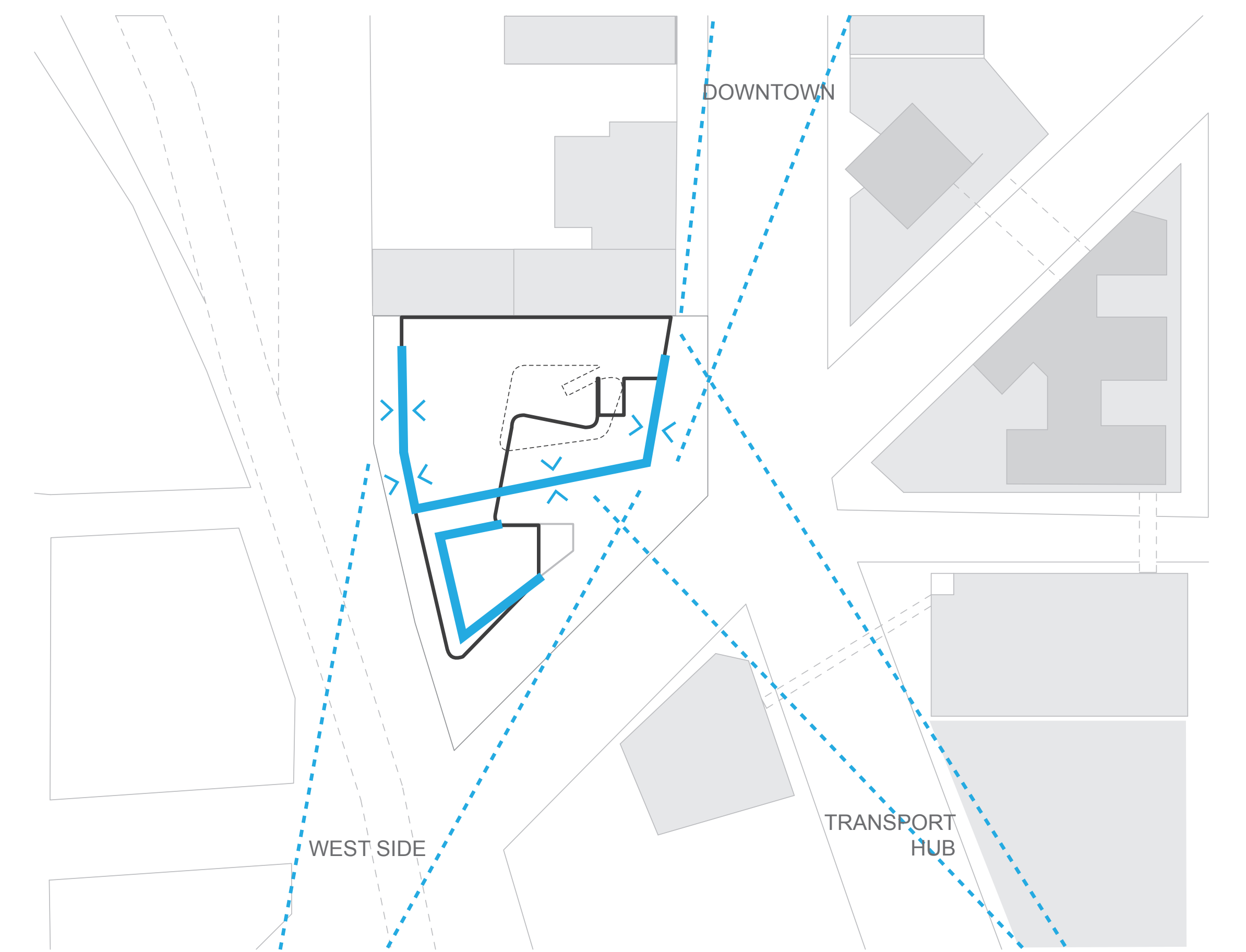

SURROUNDING VIEWS

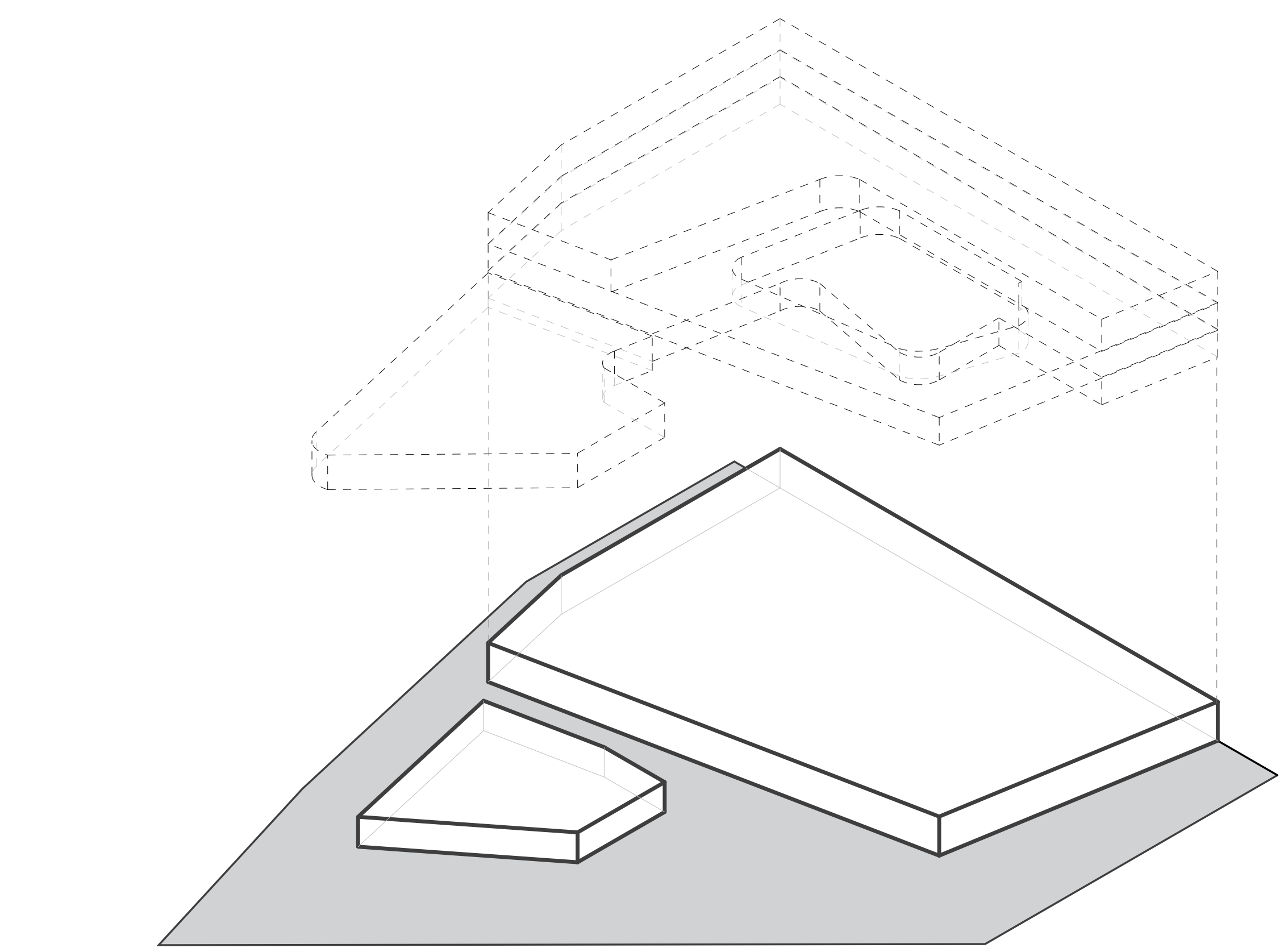
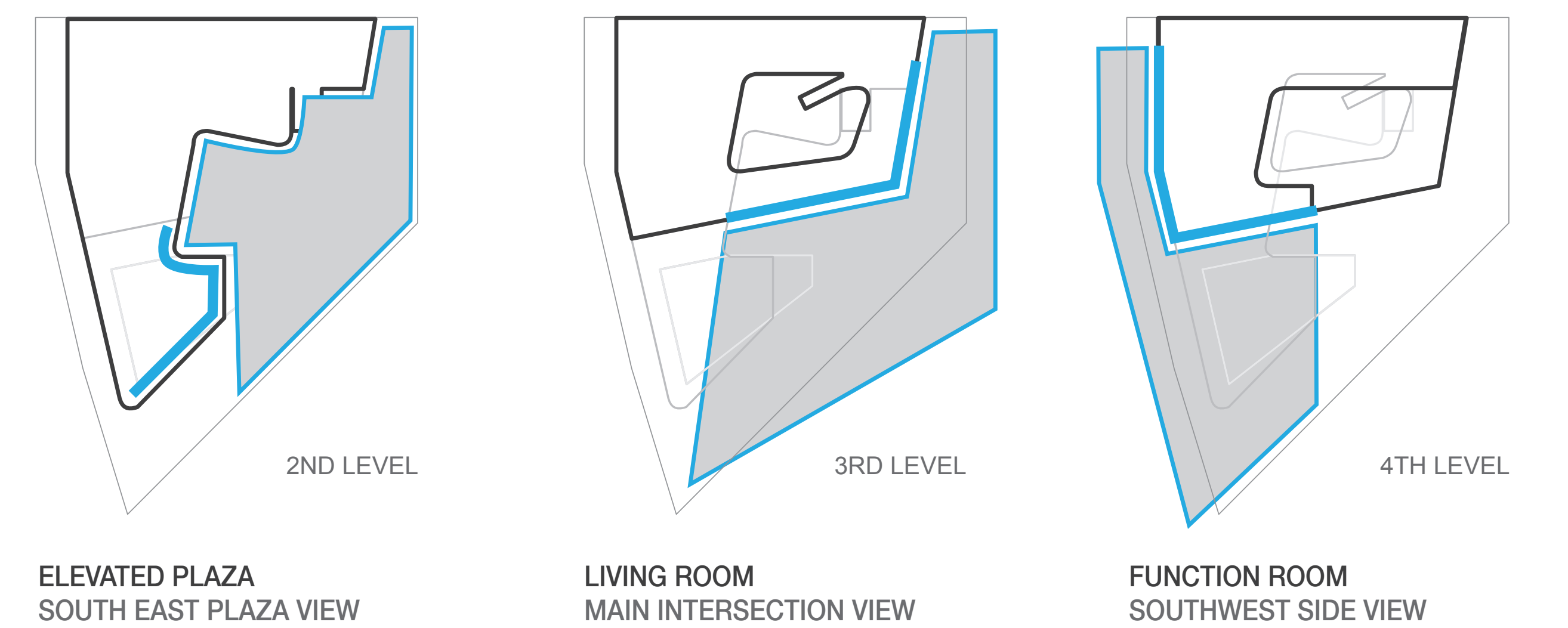
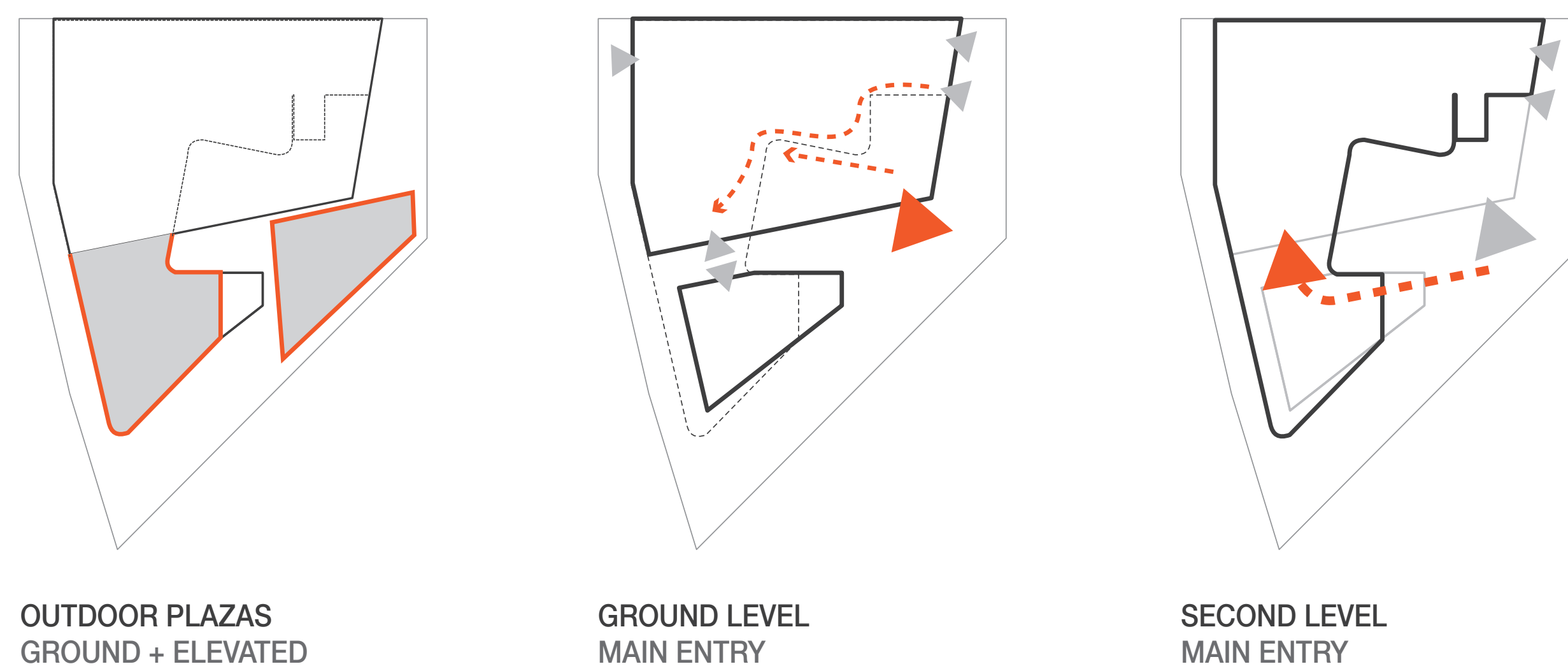
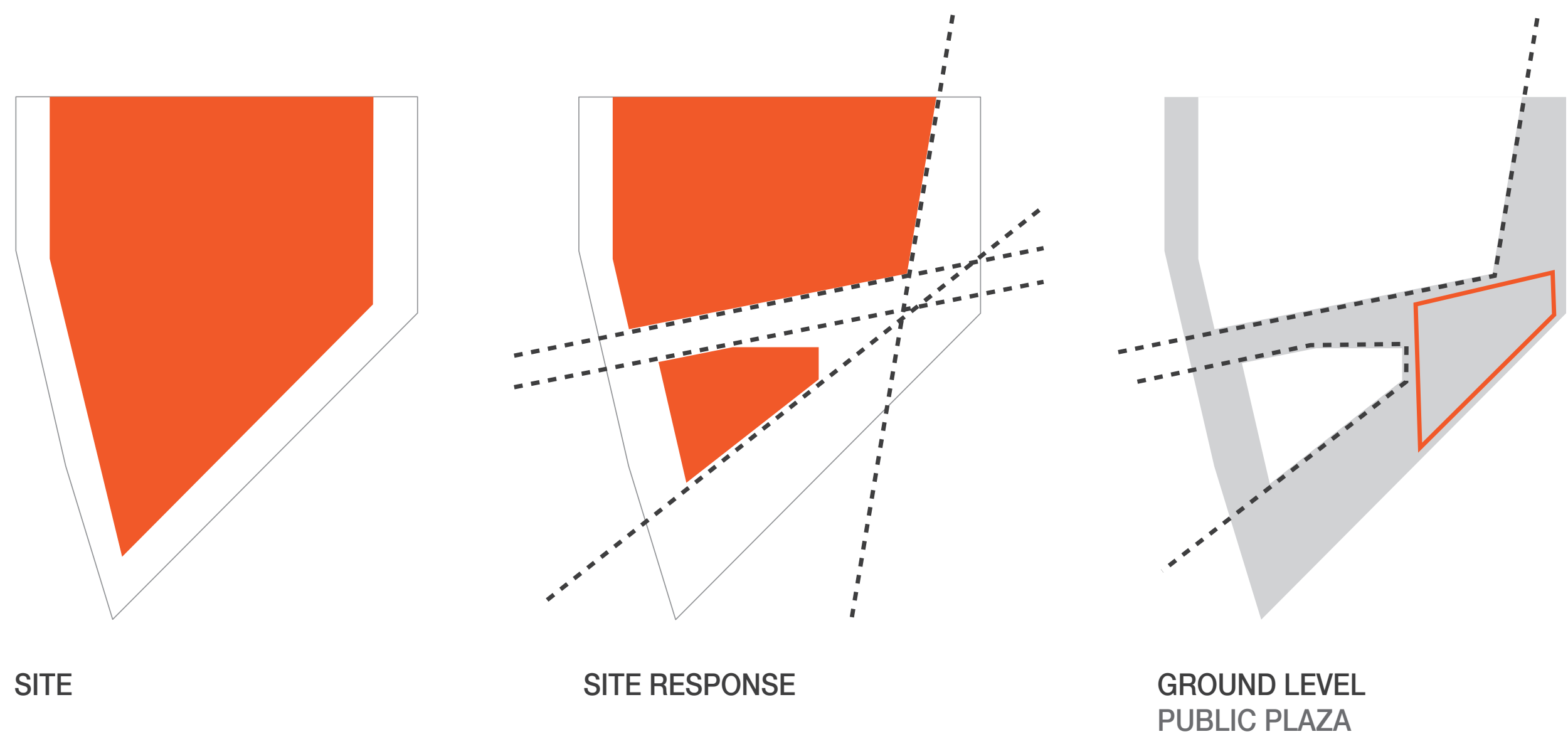

FORM

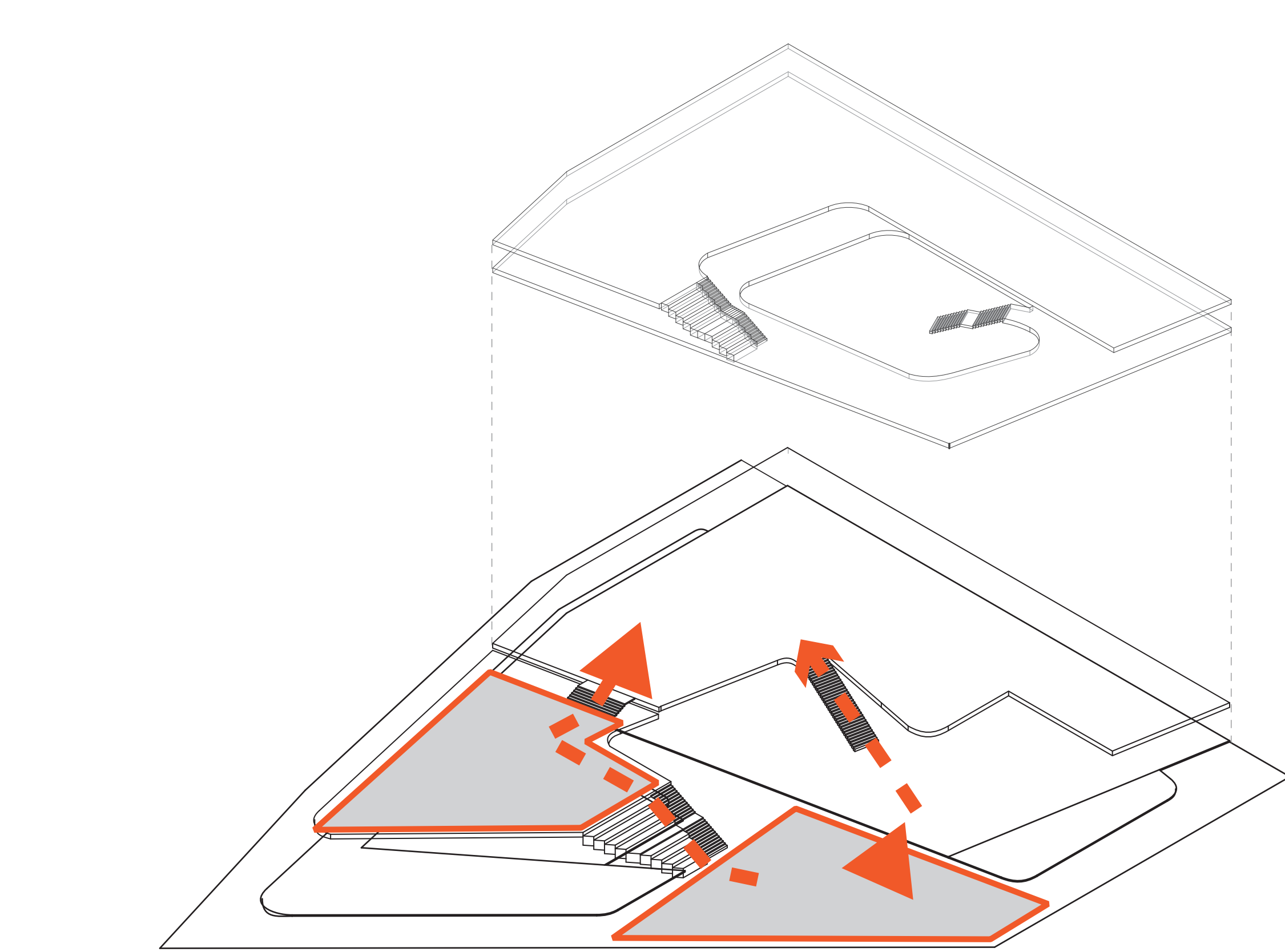

ENTRY

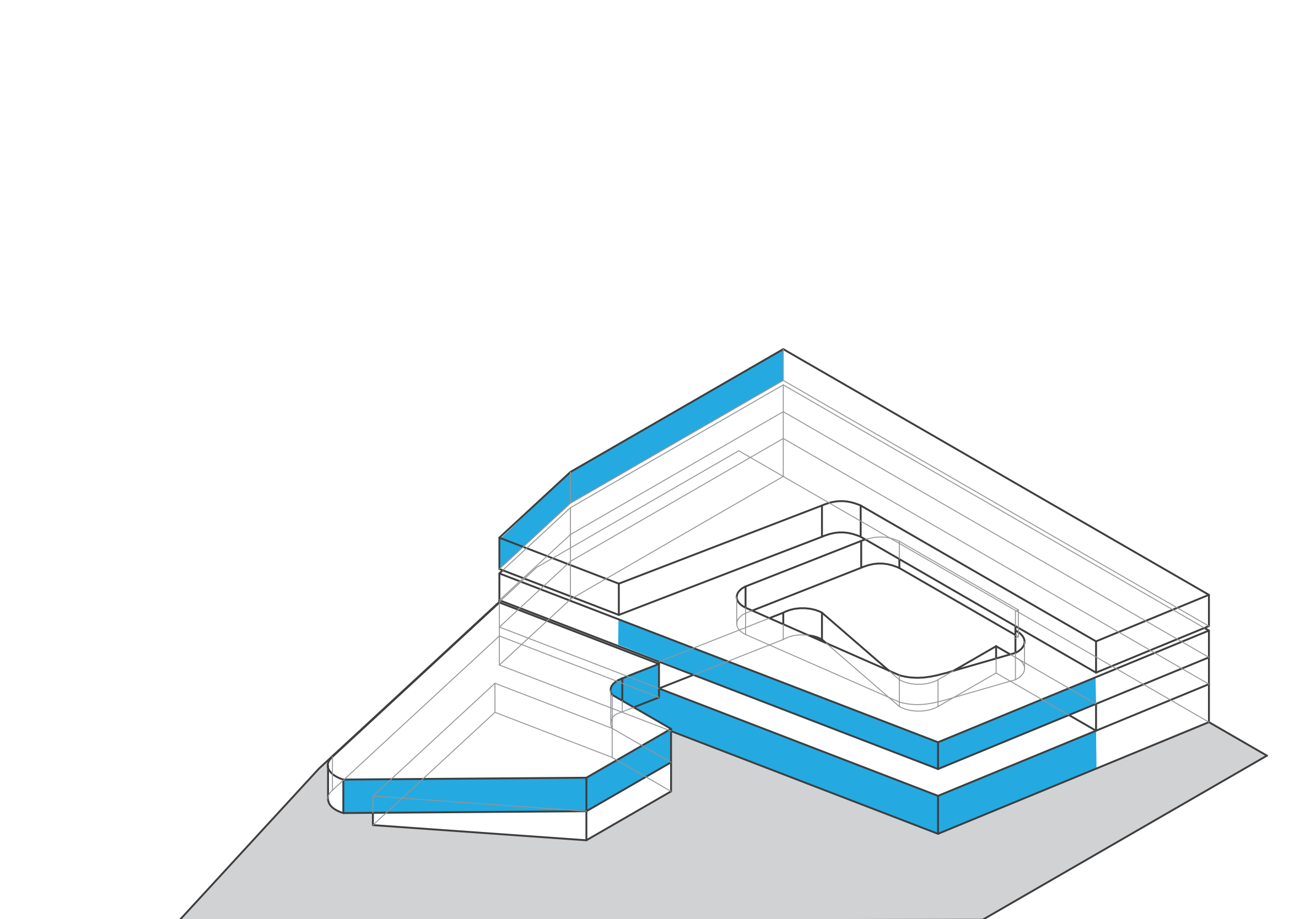

VISUAL

FORMAL DESIGN

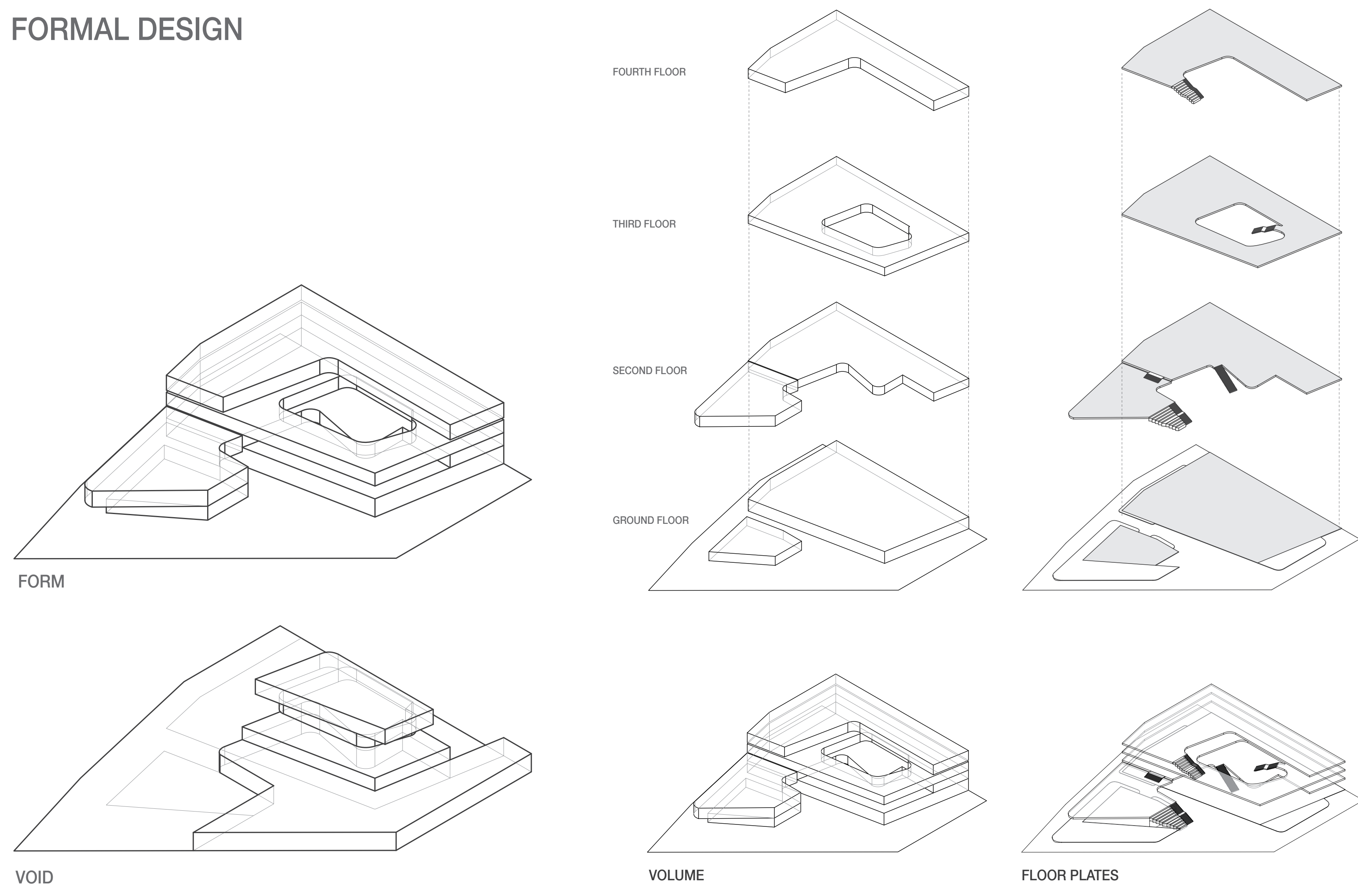

GROUND PLAZA ACTIVITY VARIATIONS

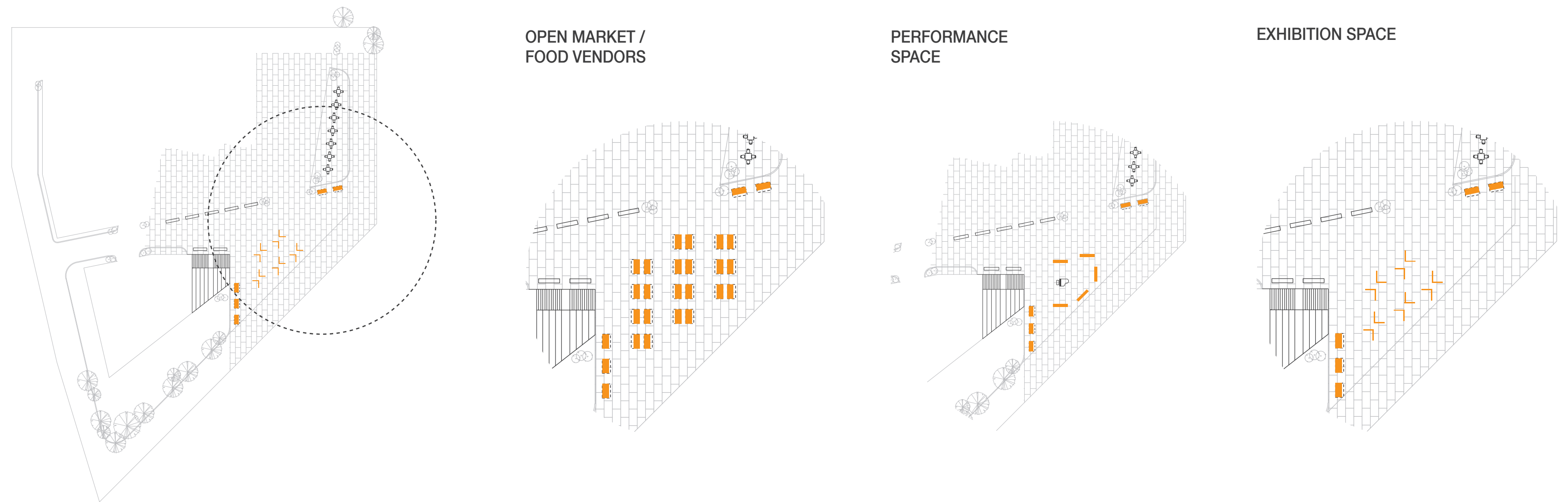

VIEW FRAMES

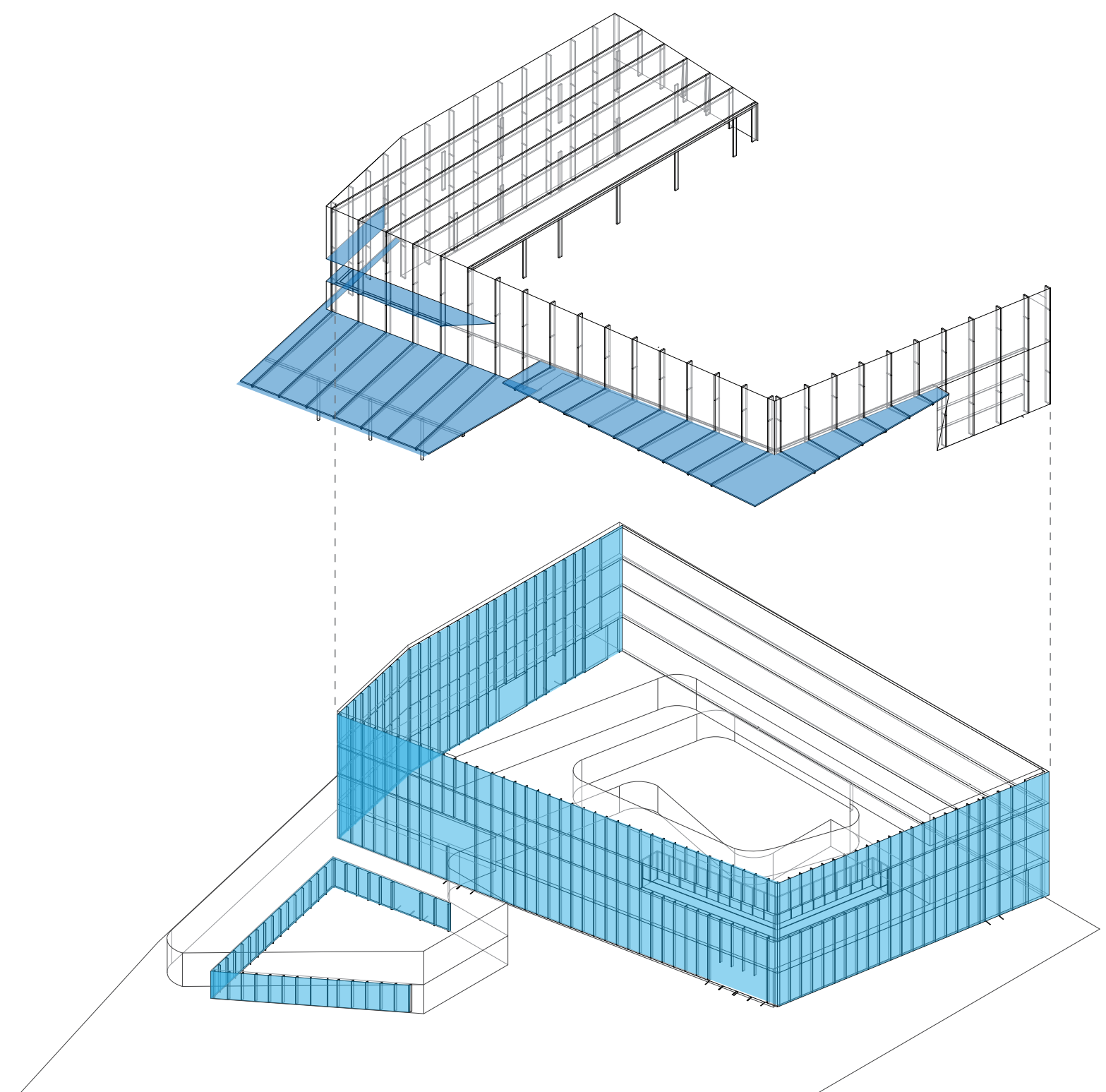

GLASS

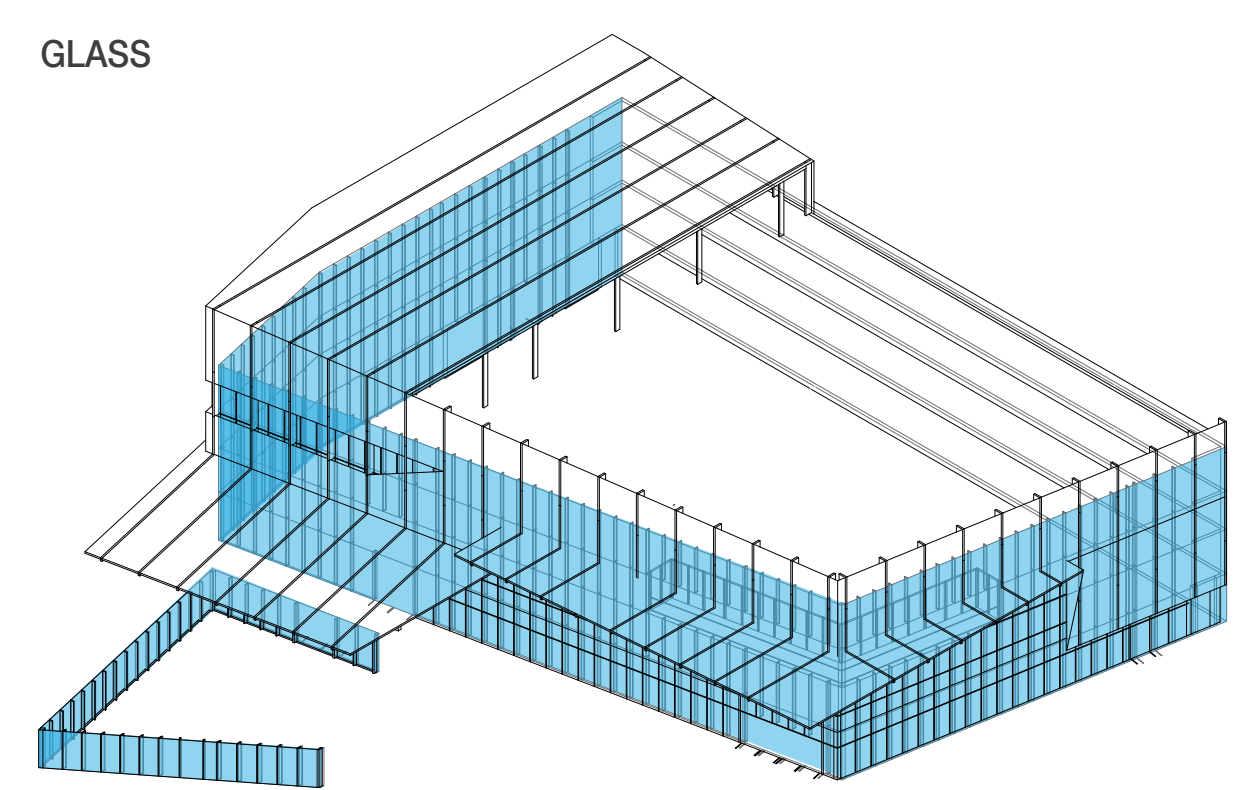

MESH

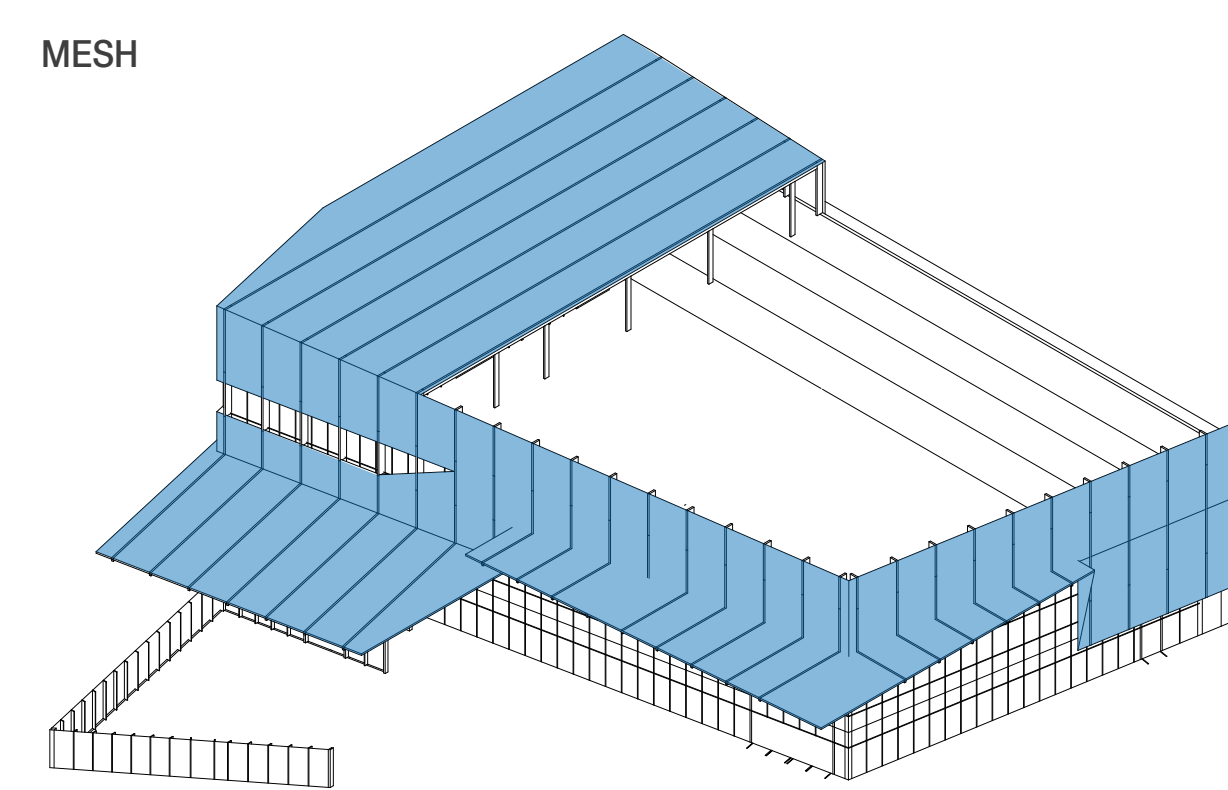

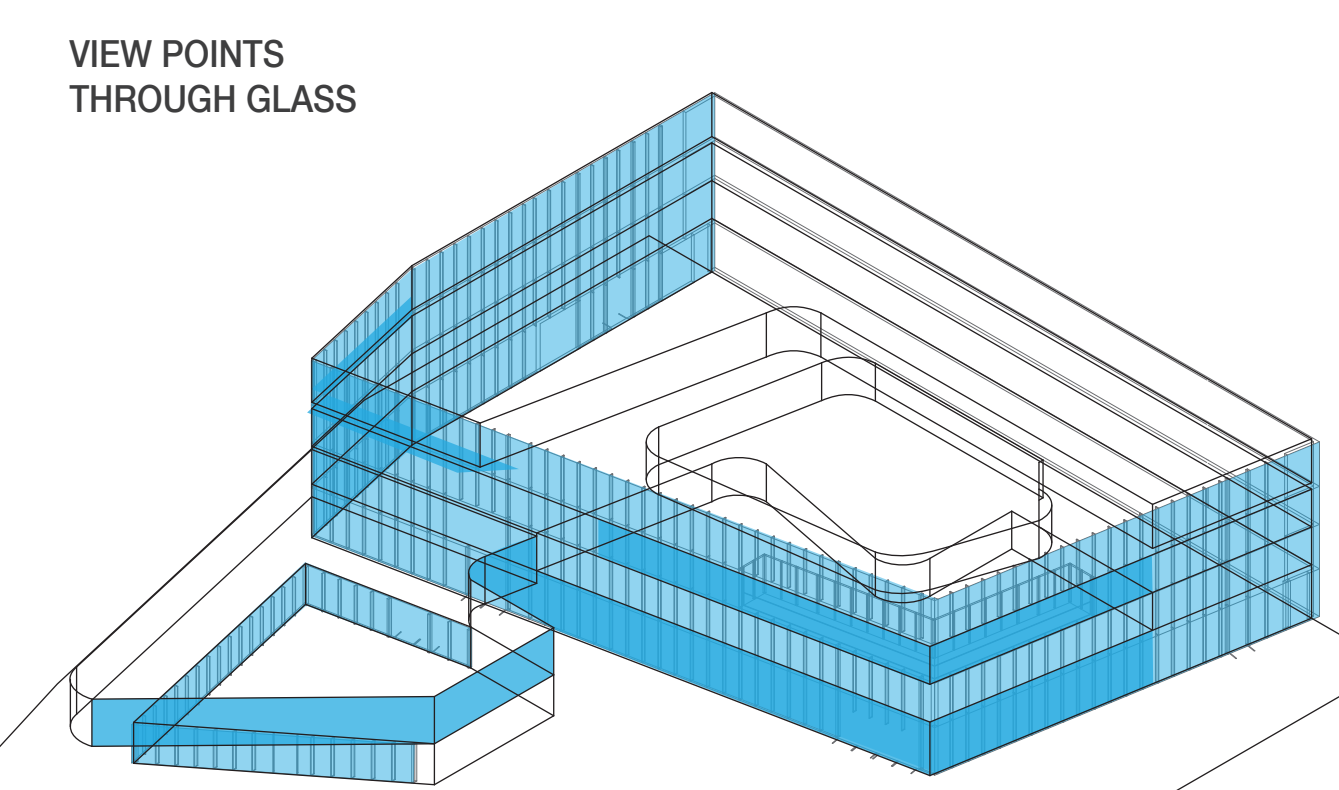

VIEW POINTS THROUGH GLASS

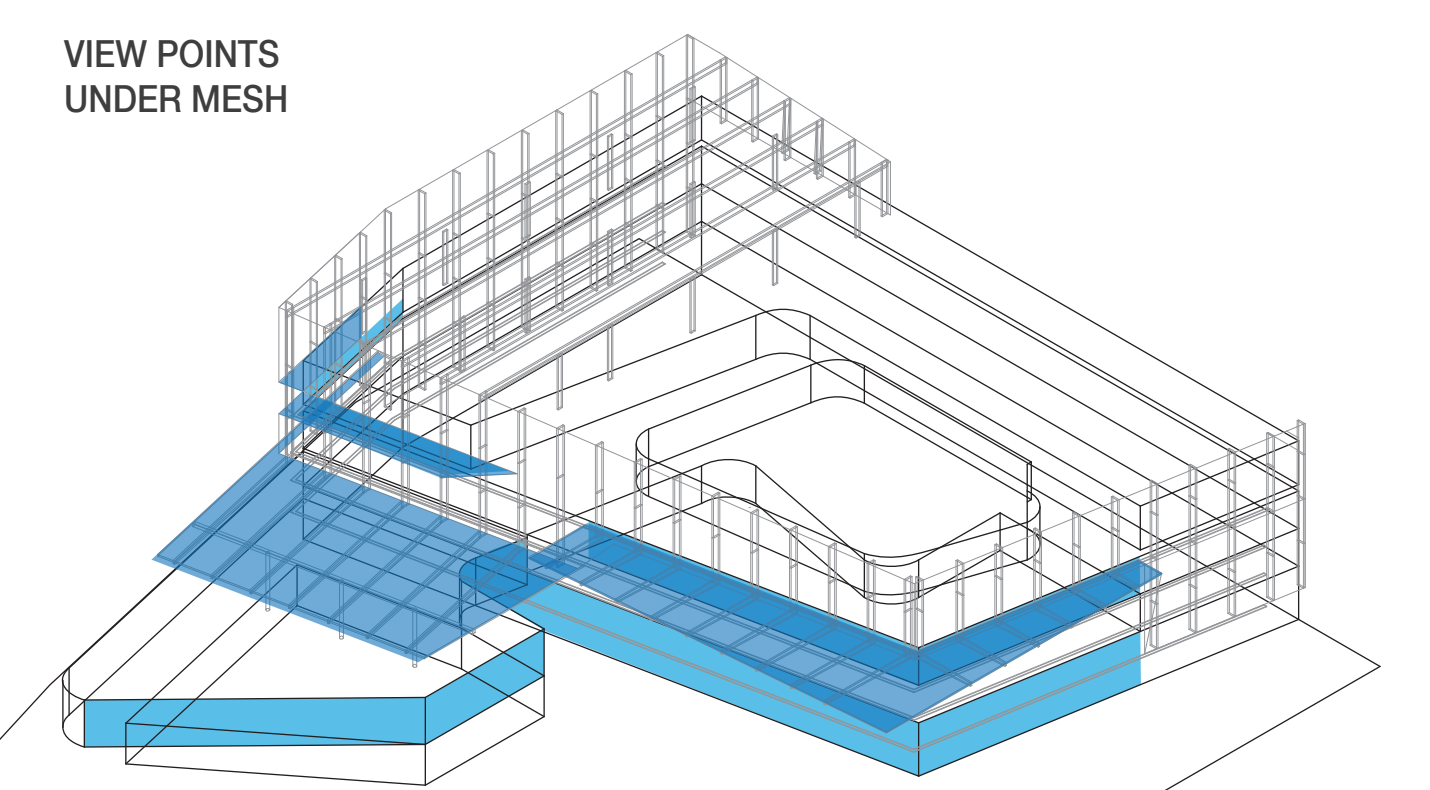

VIEW POINTS UNDER MESH



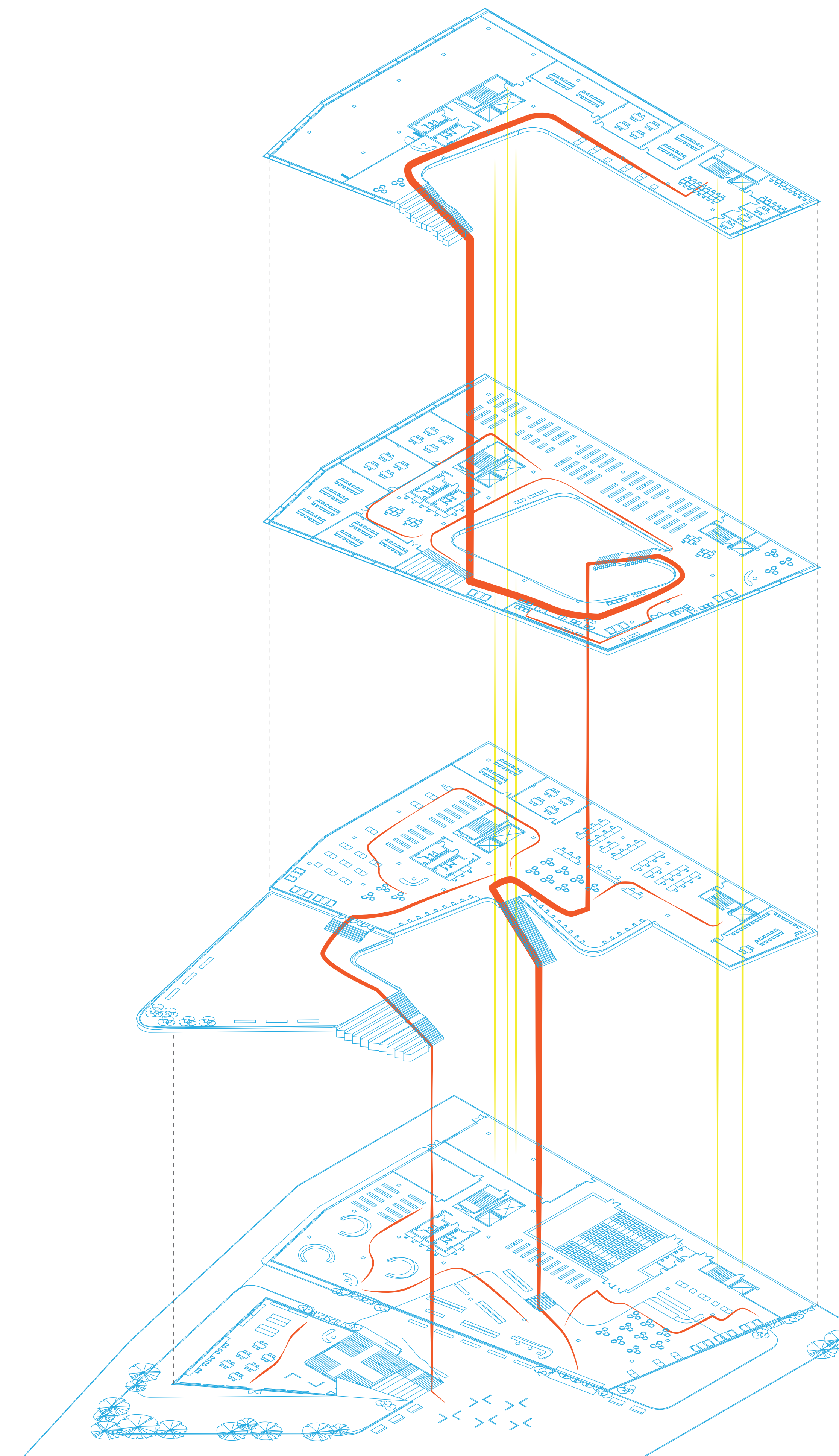

CIRCULATION

-  FLOOR CIRCULATION
-  CORE CIRCULATION



ACCESSIBILITY

-  ACCESS WITH PERMISSION
-  PARTIAL ACCESS
-  OPEN ACCESS

GROUND FLOOR
1/16' SCALE

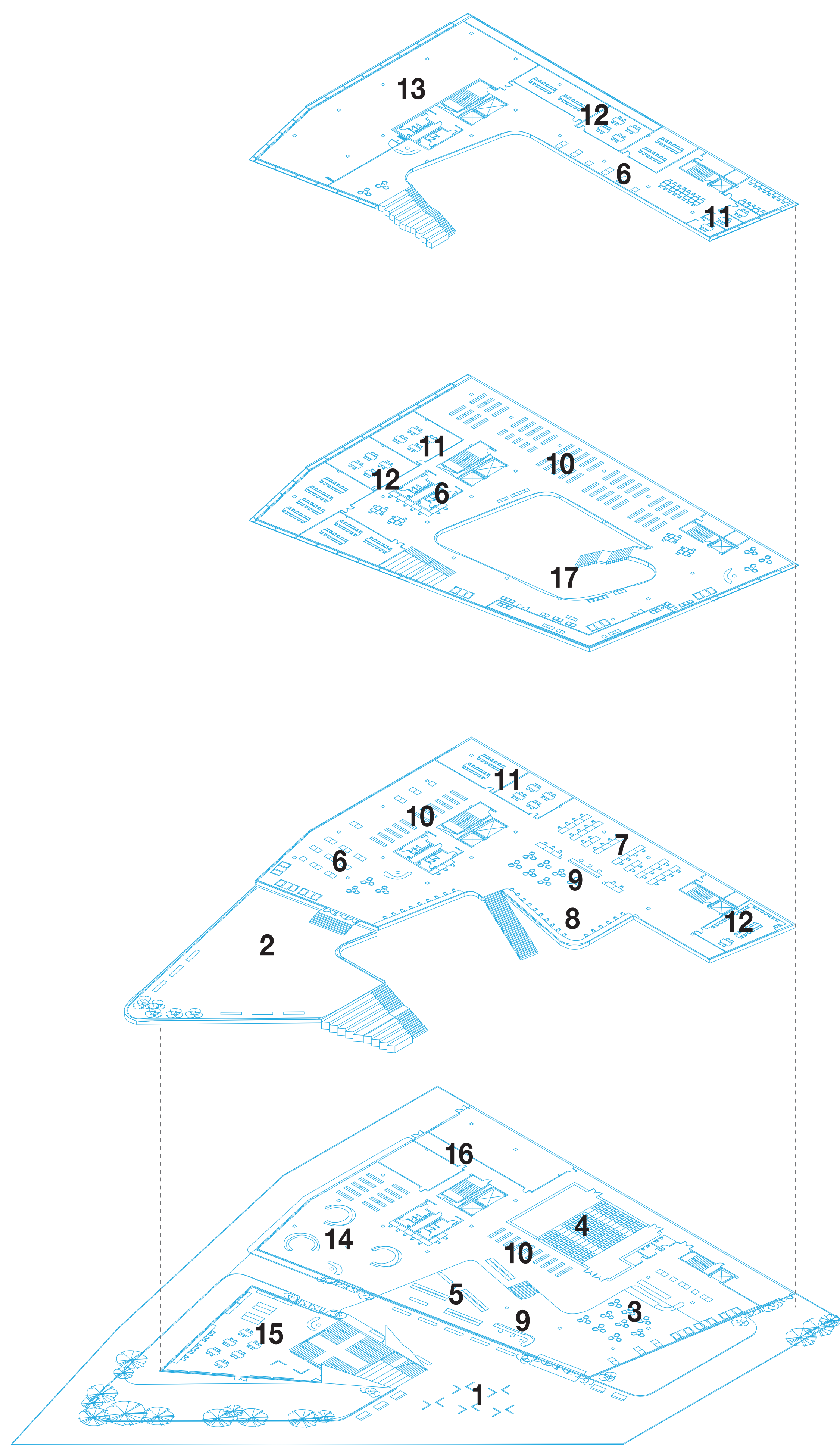

PROGRAM

- | | |
|---------------------------------|--|
| 1 GROUND PLAZA | 10 BOOK STACKS |
| 2 ELEVATED PLAZA | 11 MEETING ROOMS |
| 3 CAFE | 12 CLASSROOMS |
| 4 AUDITORIUM | 13 EVENT SPACE |
| 5 SEATING AREA | 14 CHILDREN'S |
| 6 STUDY AREA | 15 GENEALOGY |
| 7 COMPUTER CLUSTER | 16 STAFF OFFICE |
| 8 PERSONAL COMPUTER AREA | 17 LIVING ROOM
COMFORTABLE SEATING |
| 9 INFORMATION | |

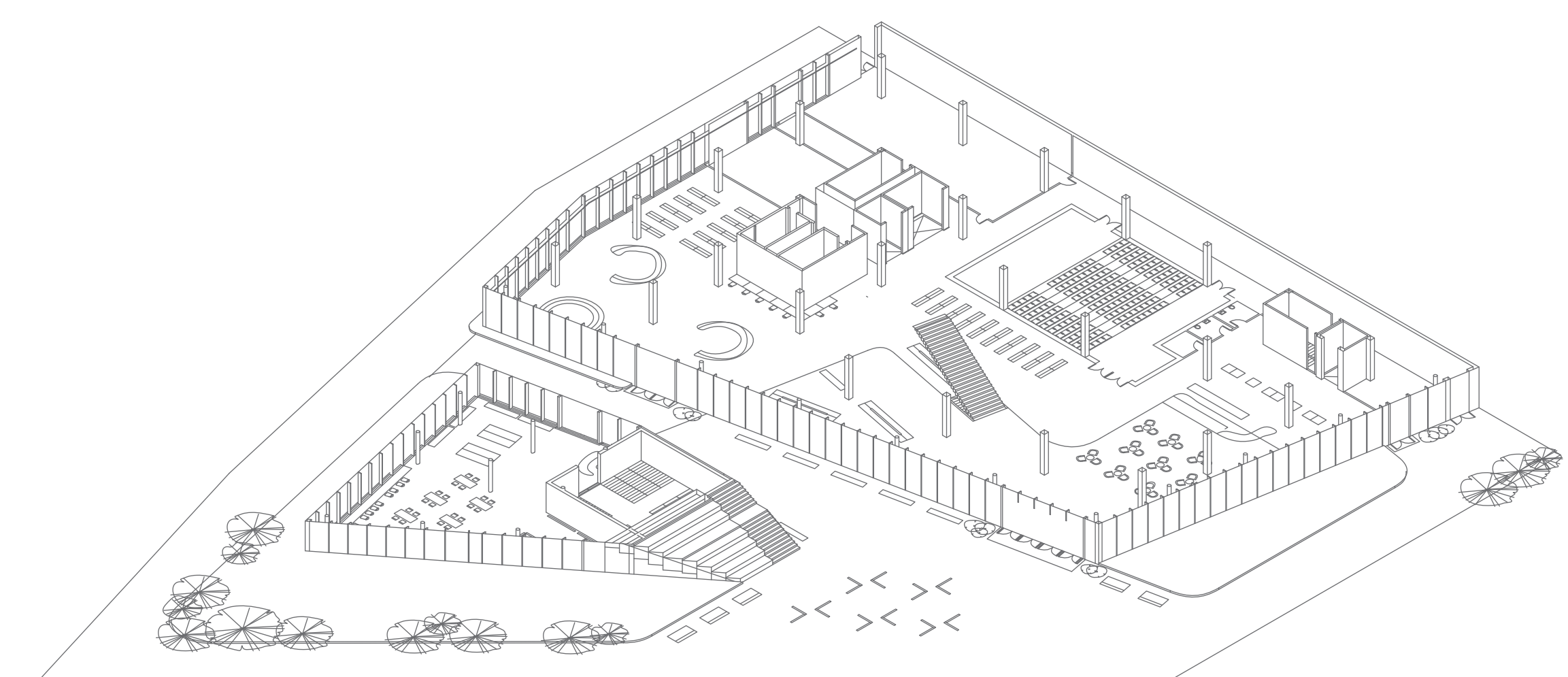
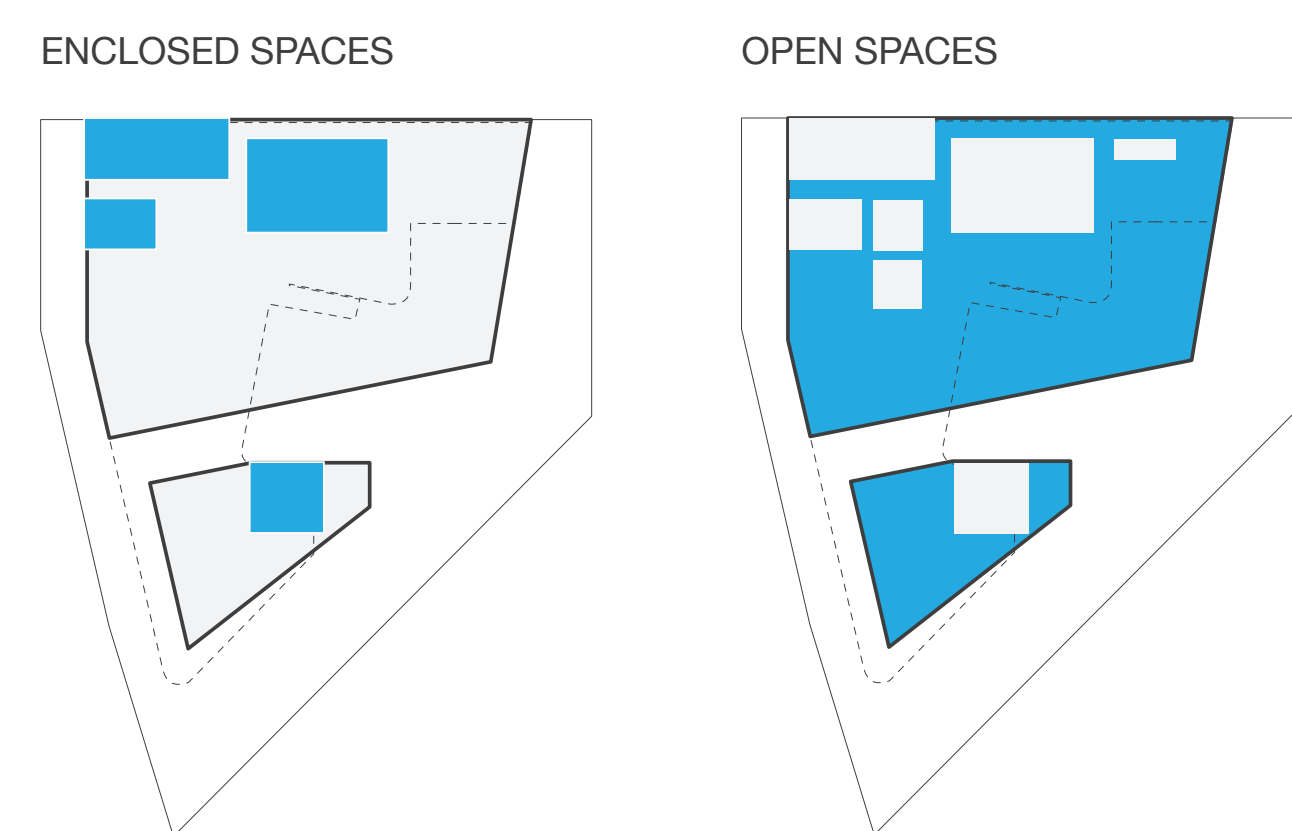
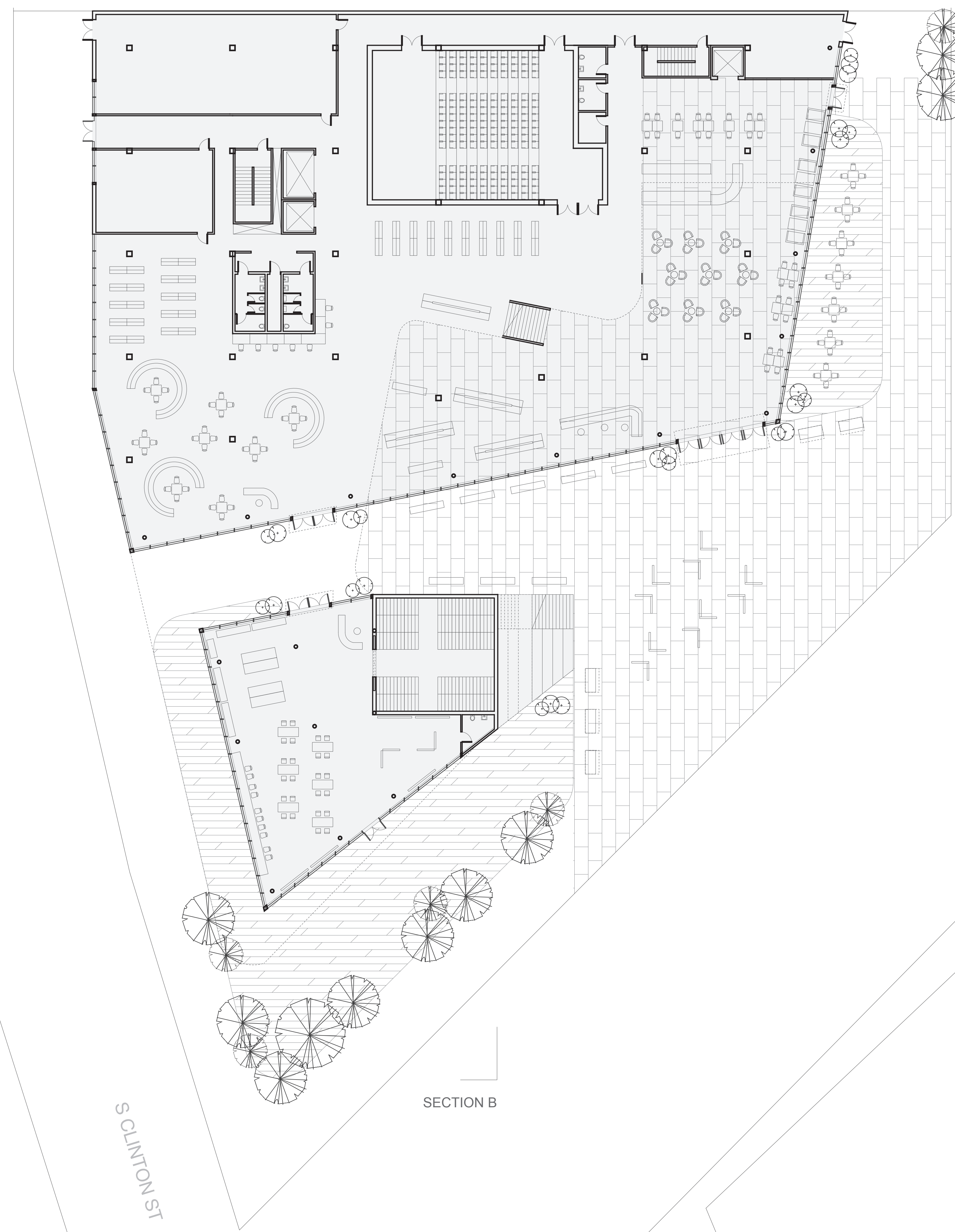

SECOND FLOOR

TECHNOLOGY /
SERVICE AND SUPPORT

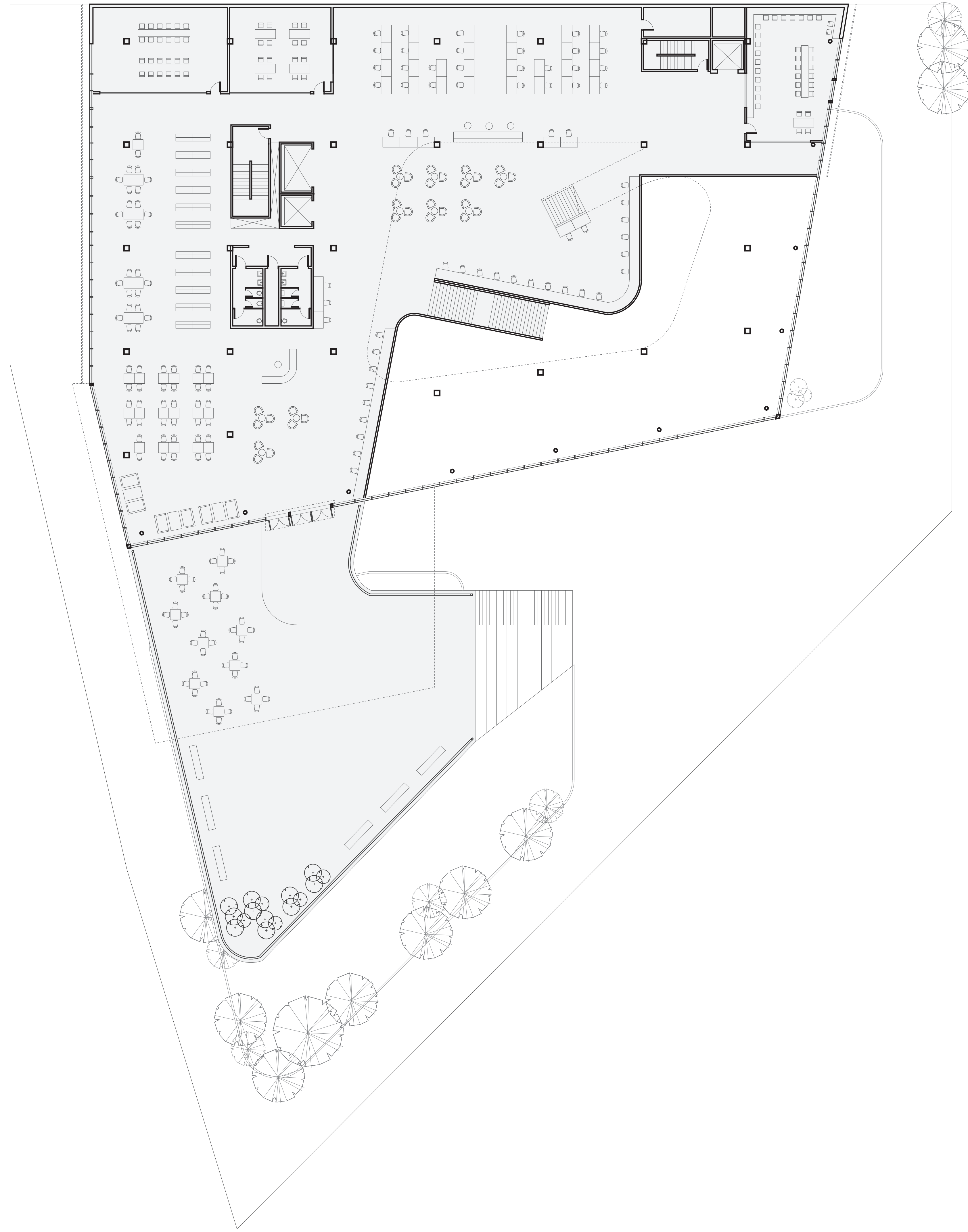

THIRD FLOOR

BOOK STACK /
READING SPACE

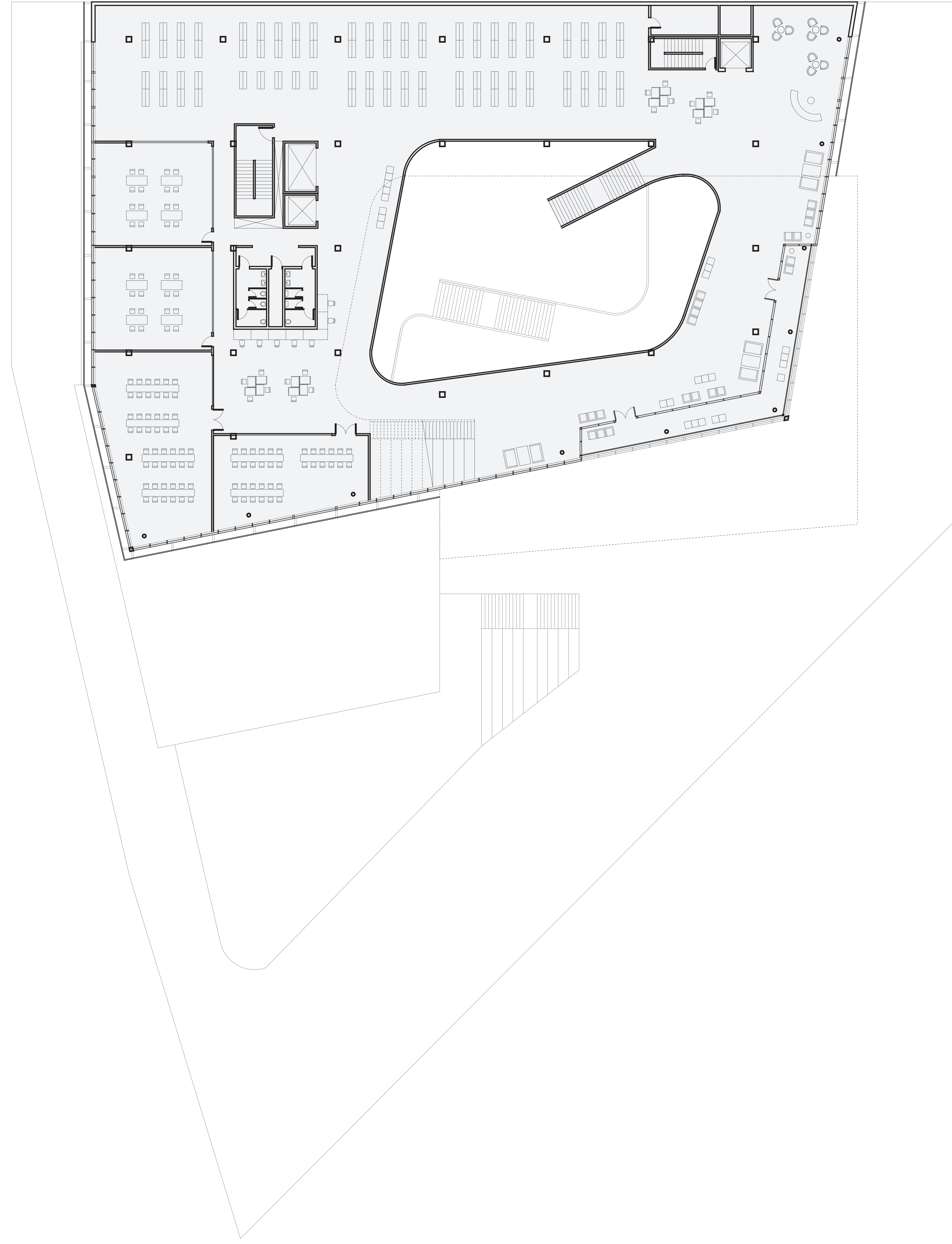

FOURTH FLOOR

EVENT SPACE /
CLASS AND MEETING ROOMS

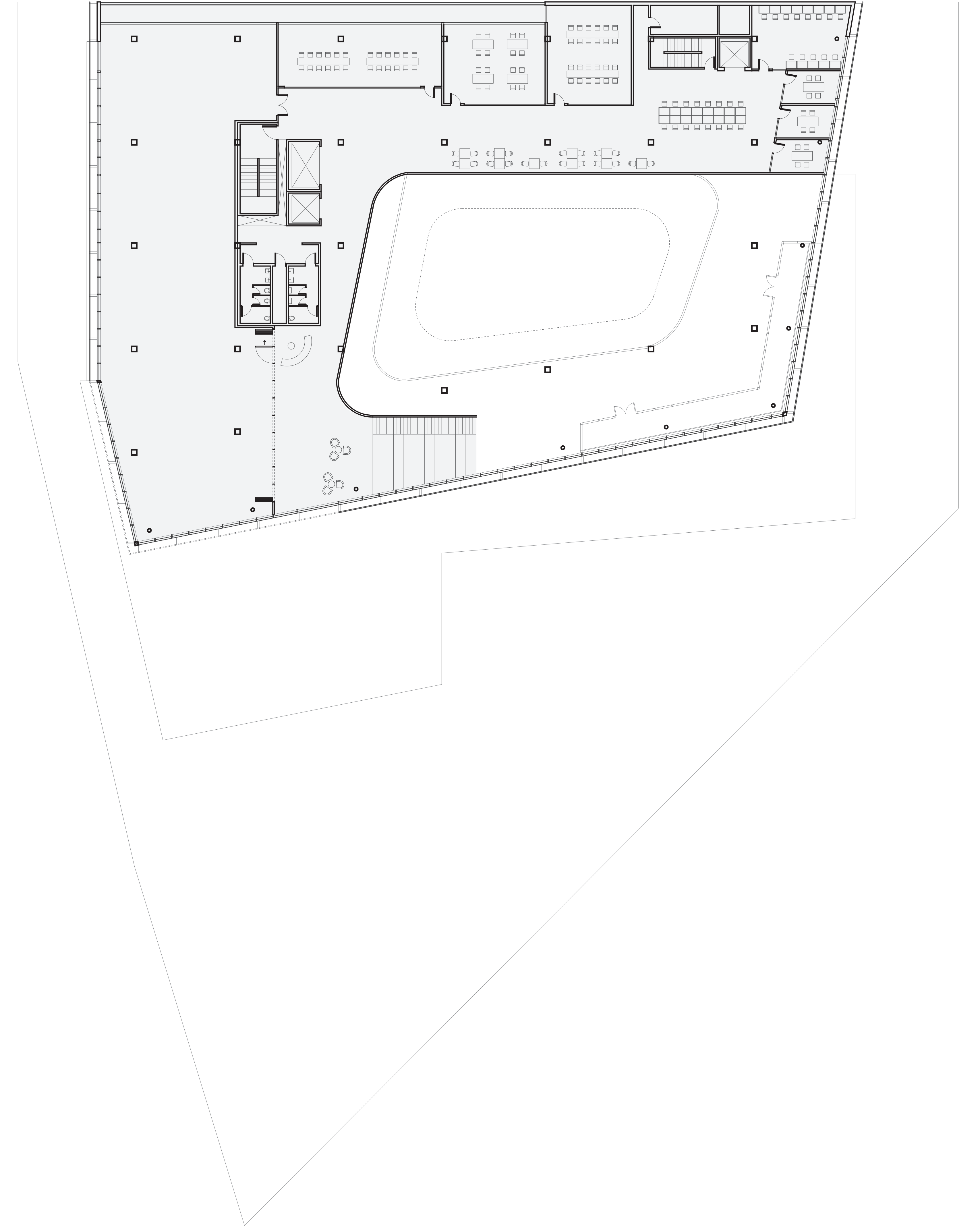

ENCLOSED SPACES

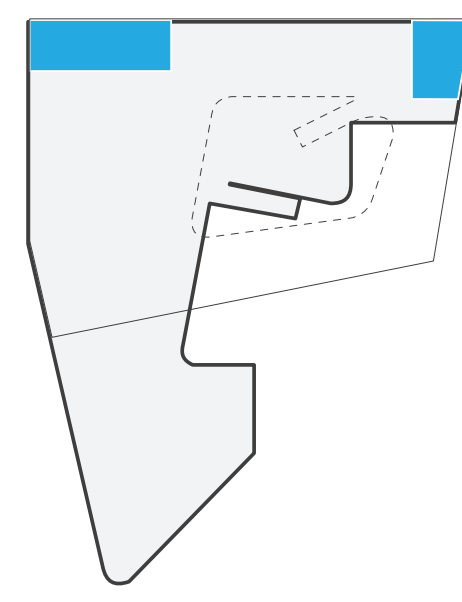

OPEN SPACES

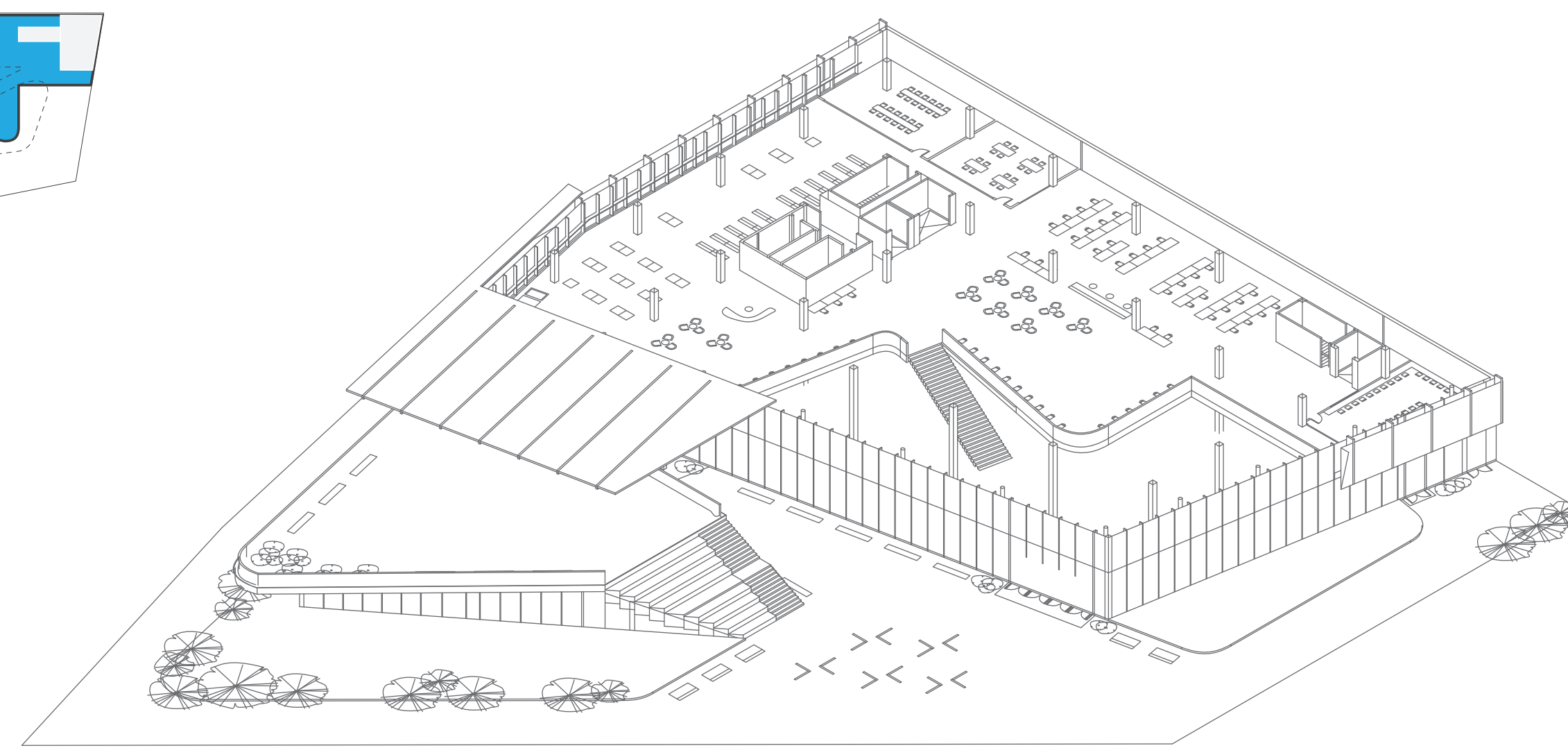
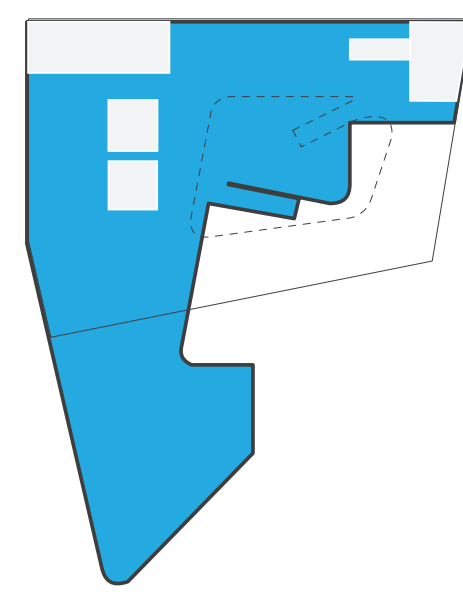

ENCLOSED SPACES

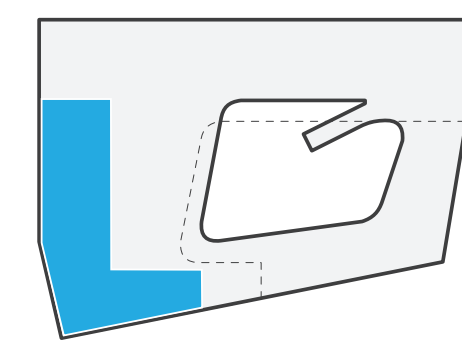

OPEN SPACES

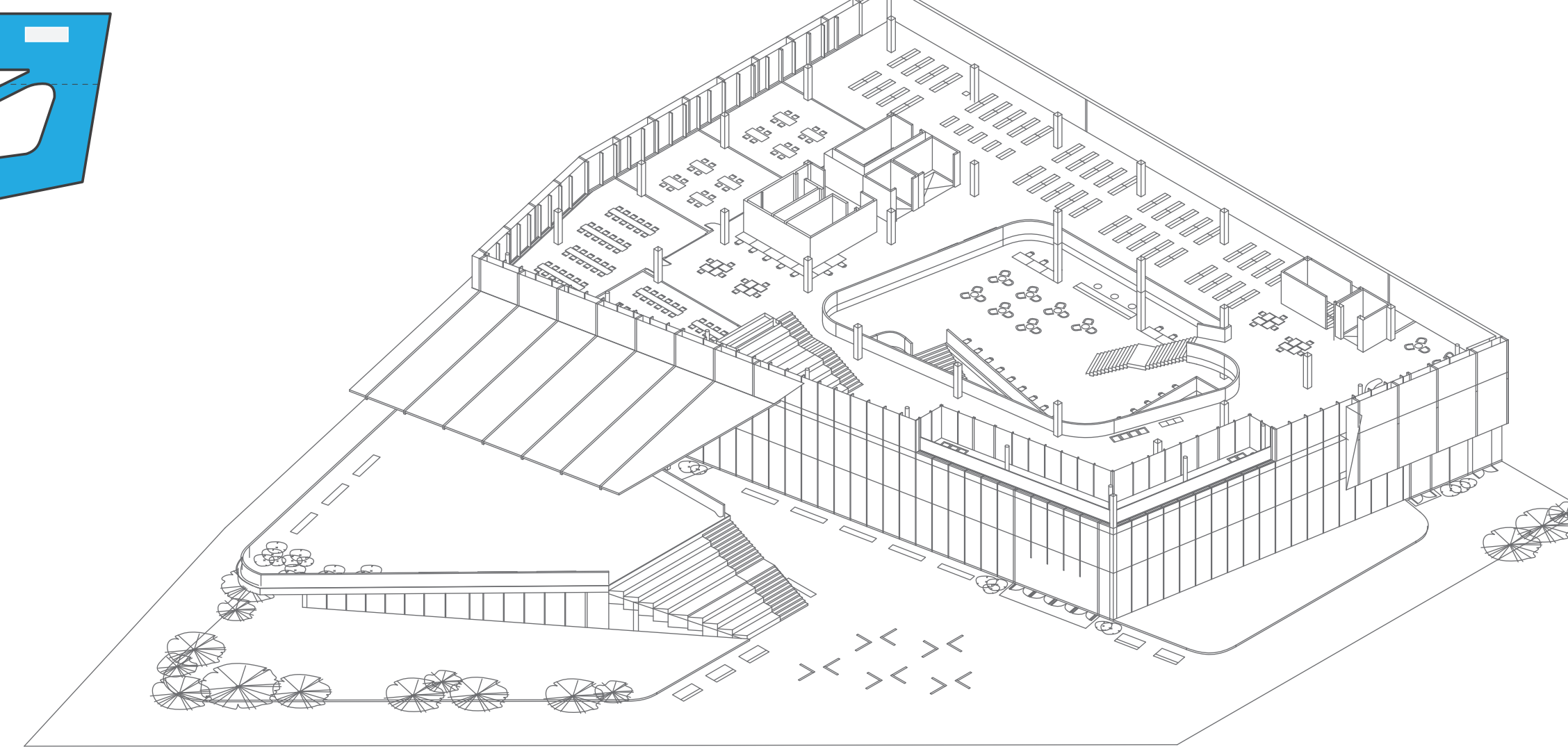
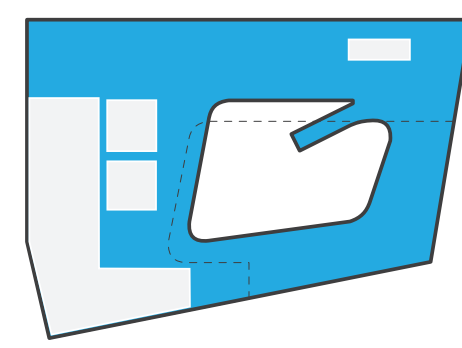

ENCLOSED SPACES

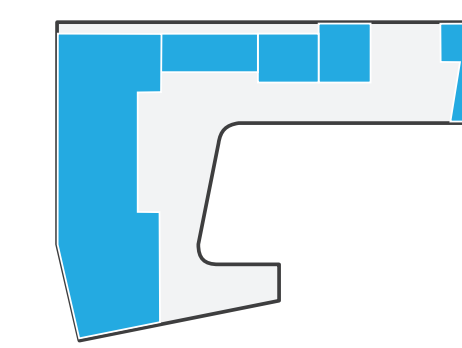

OPEN SPACES

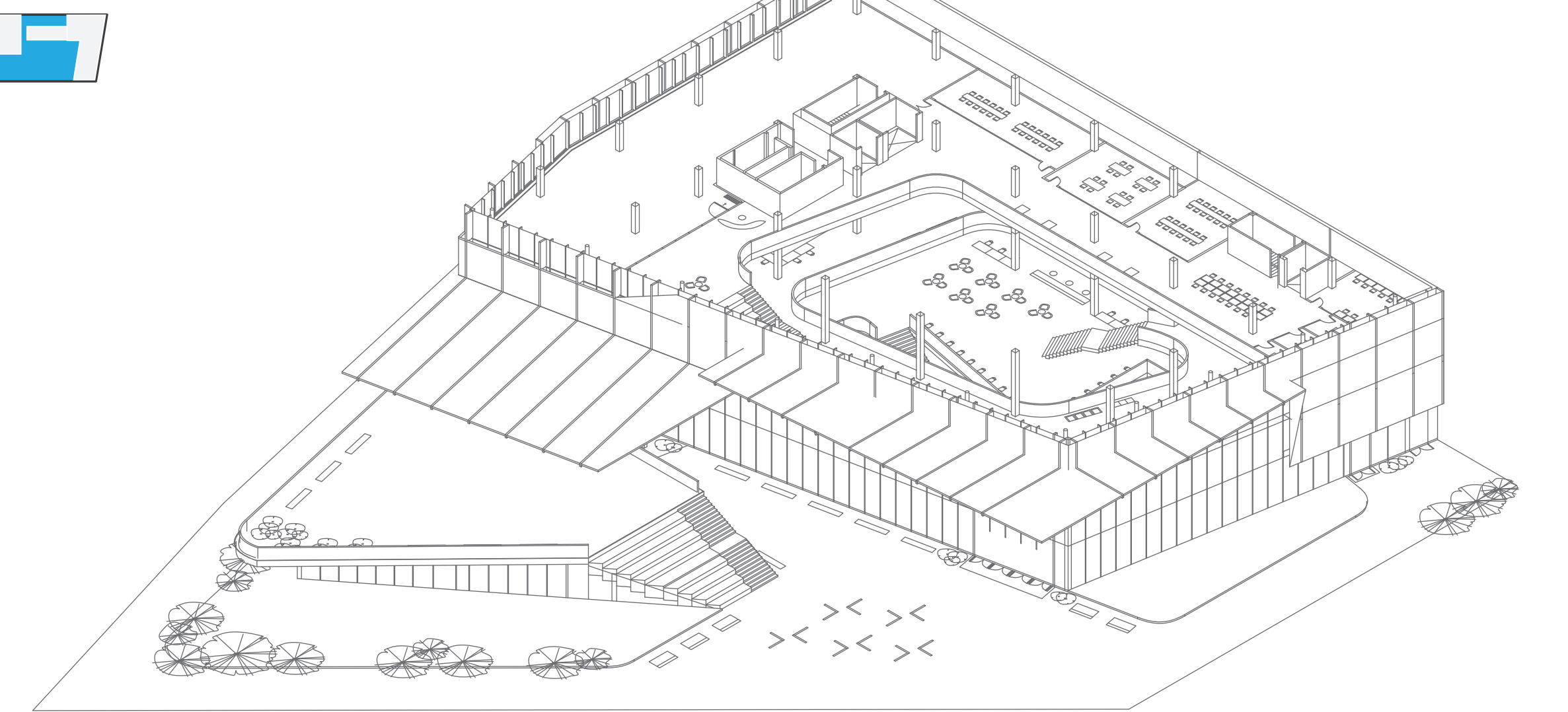
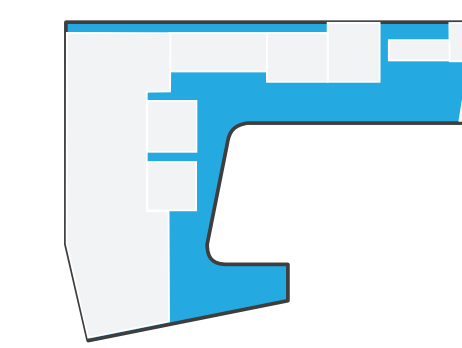

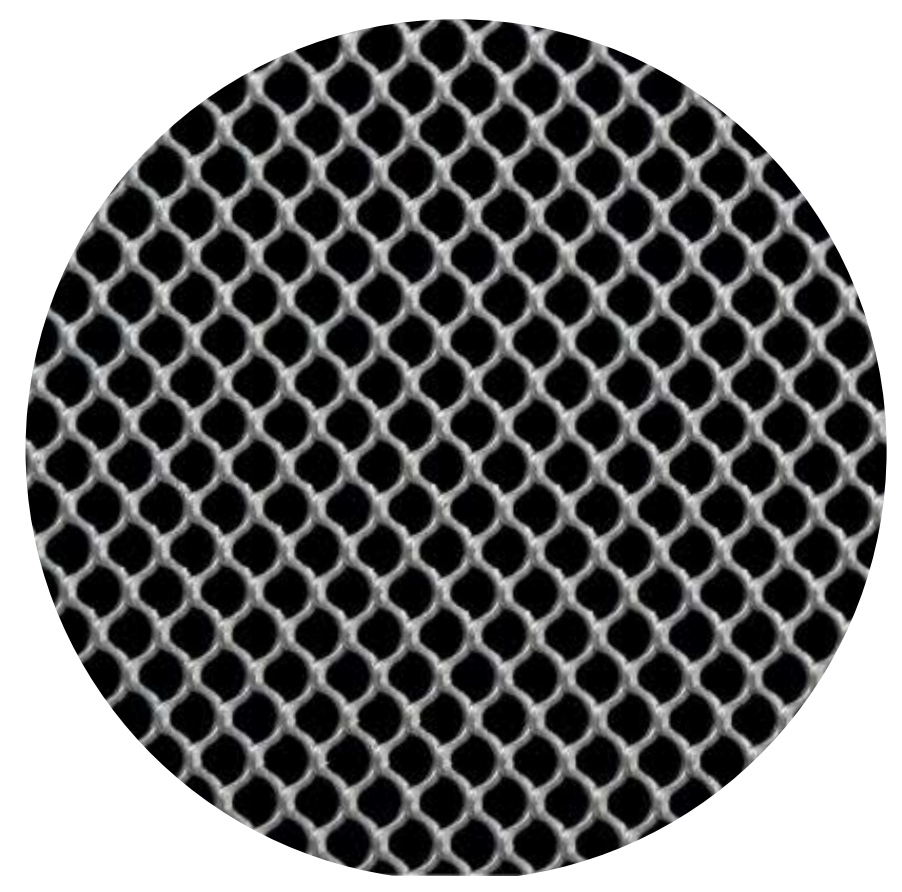

METAL MESH

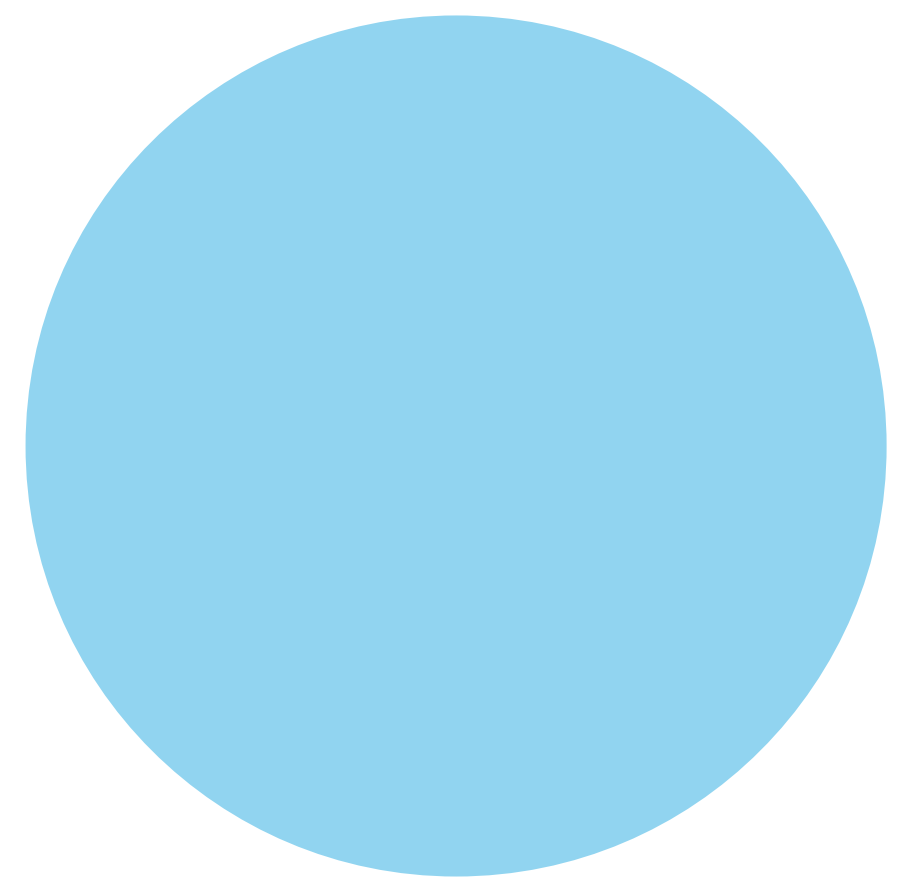

CLEAR GLASS



CONCRETE

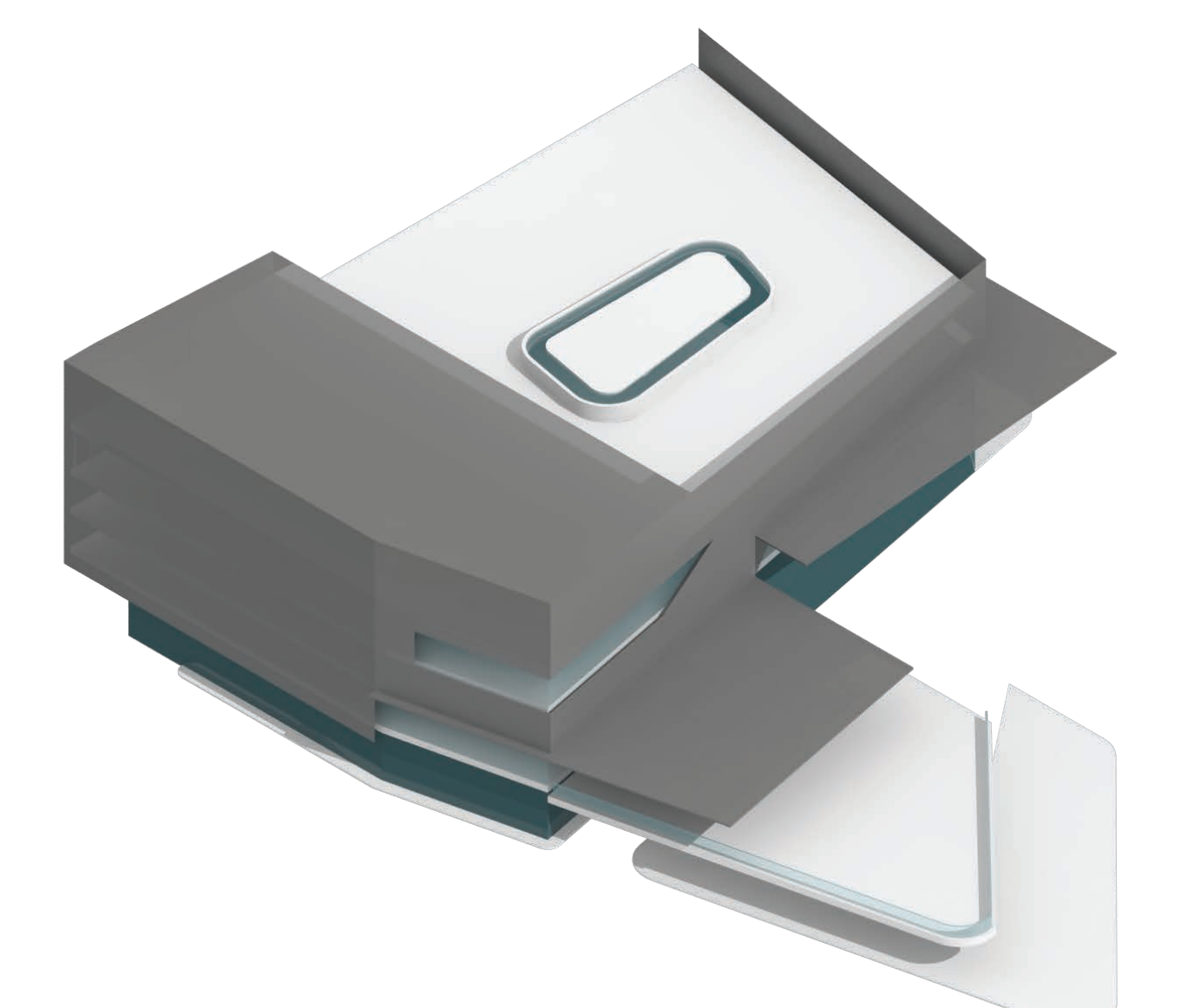
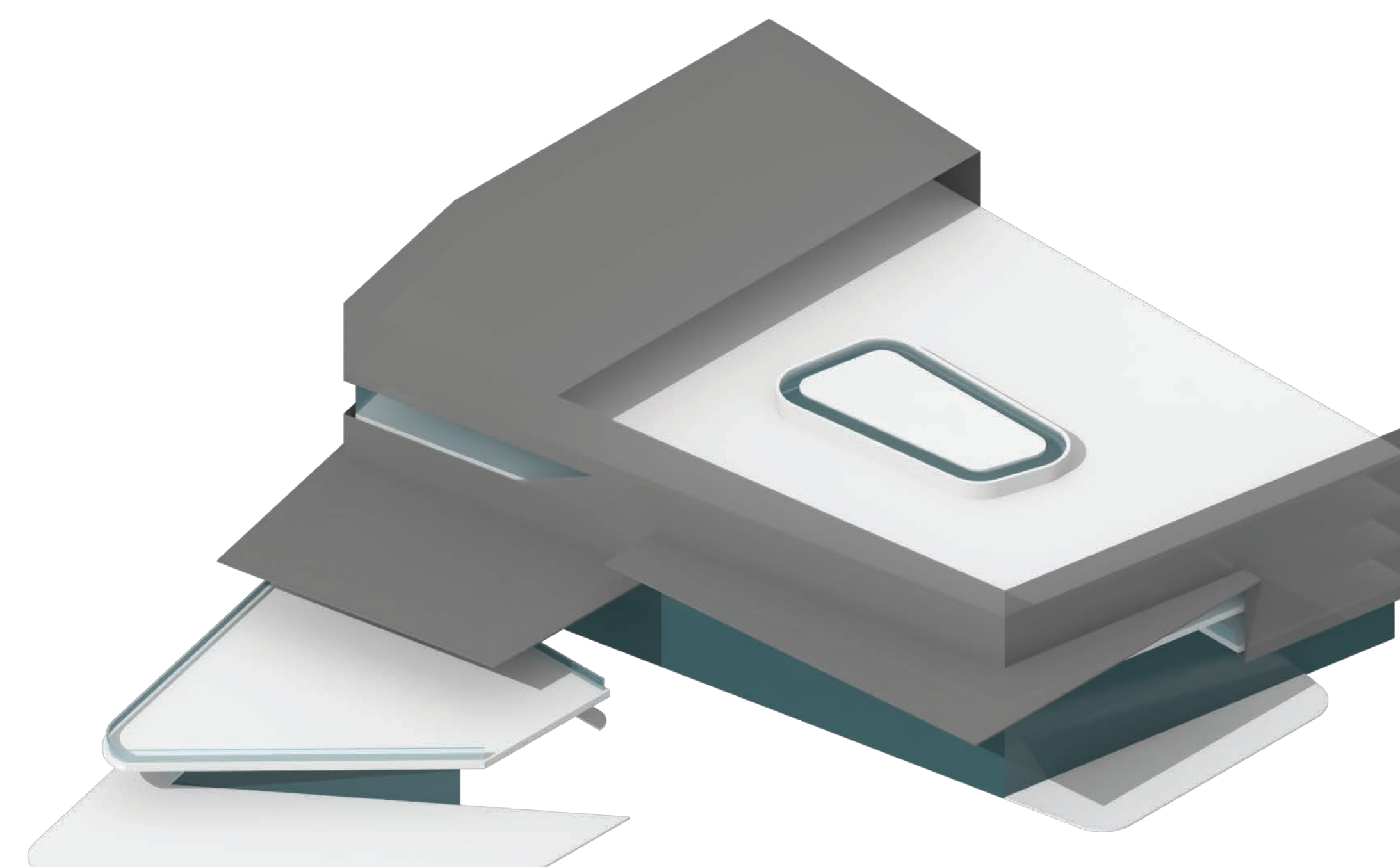
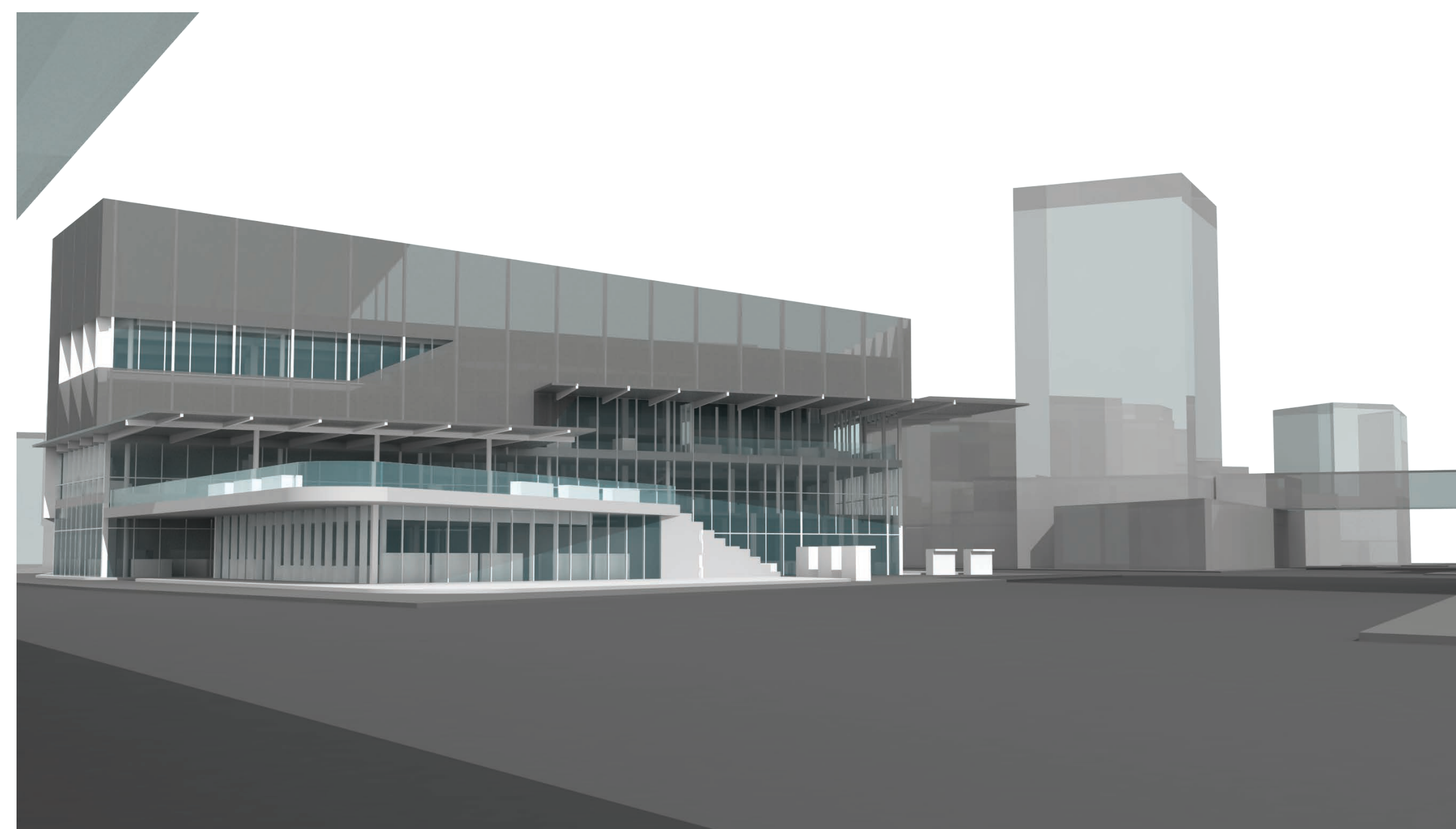
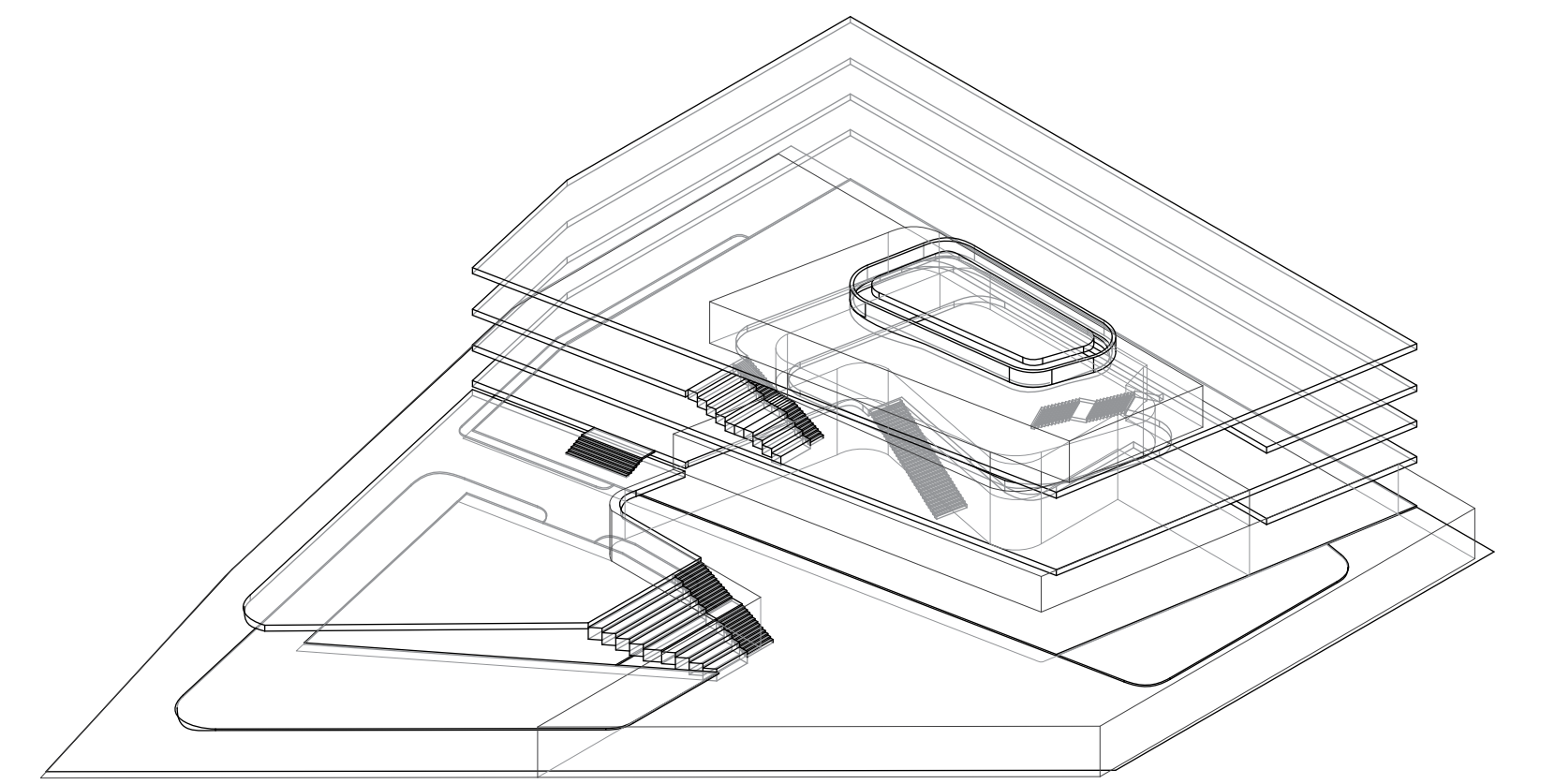
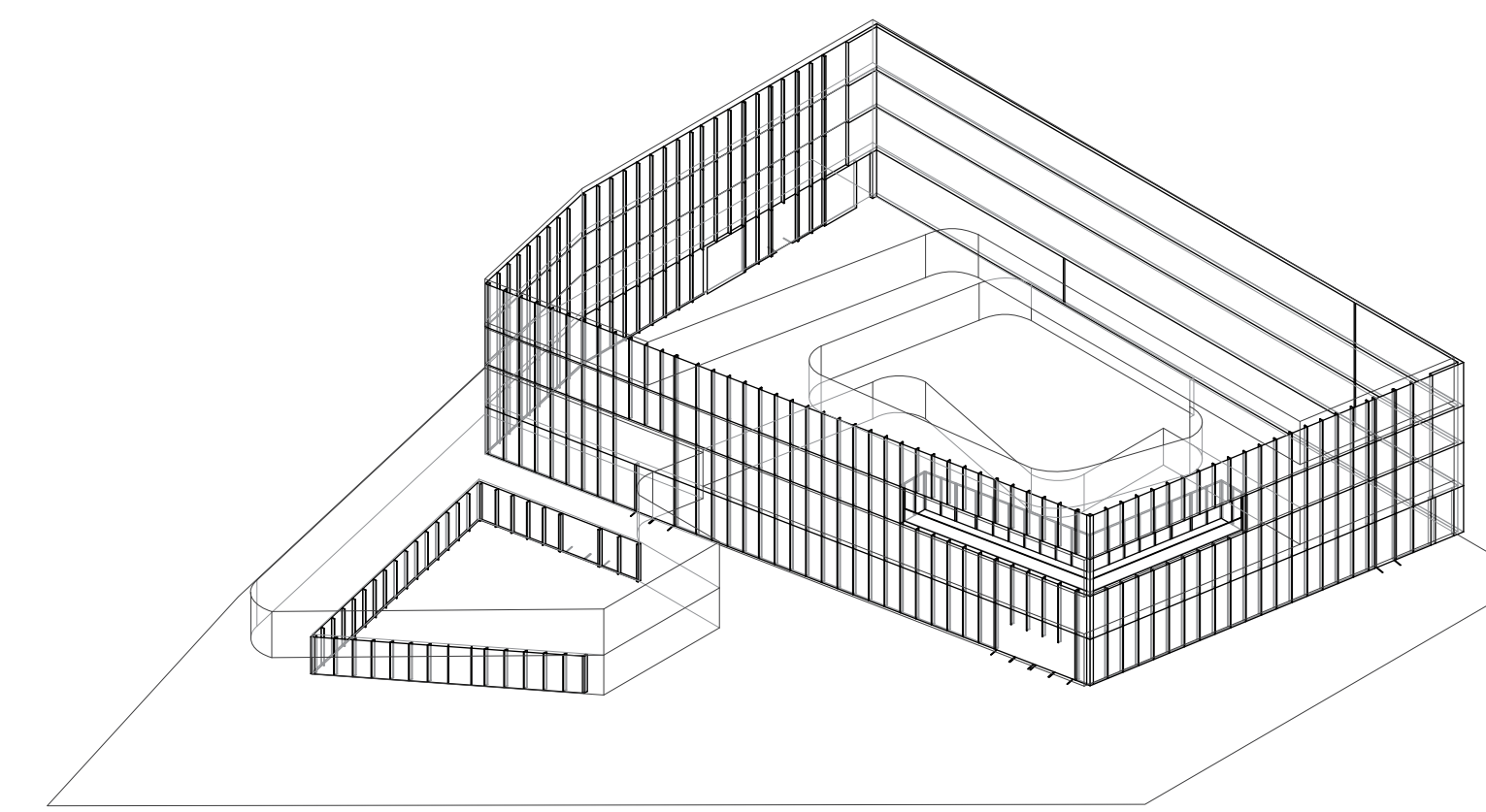
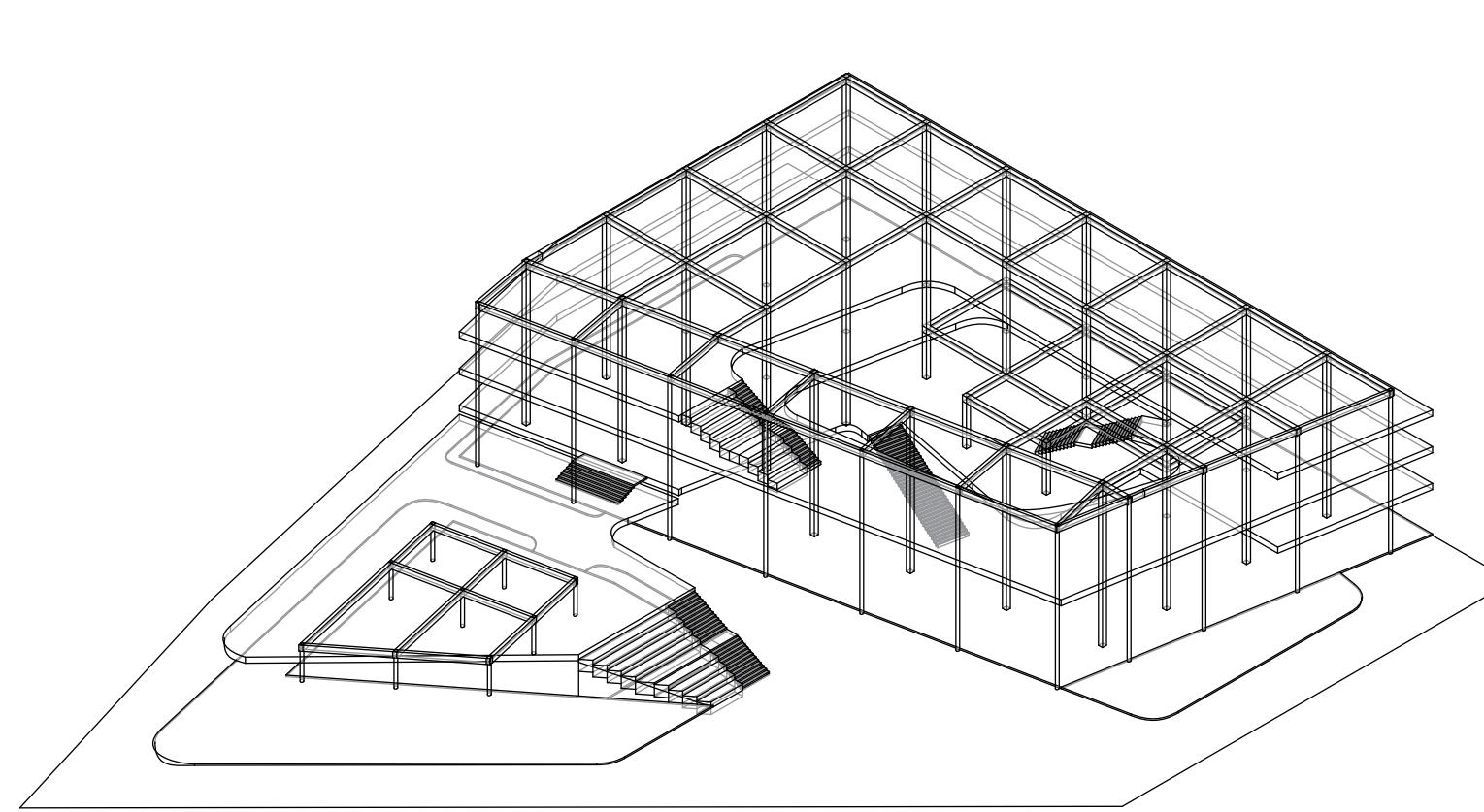
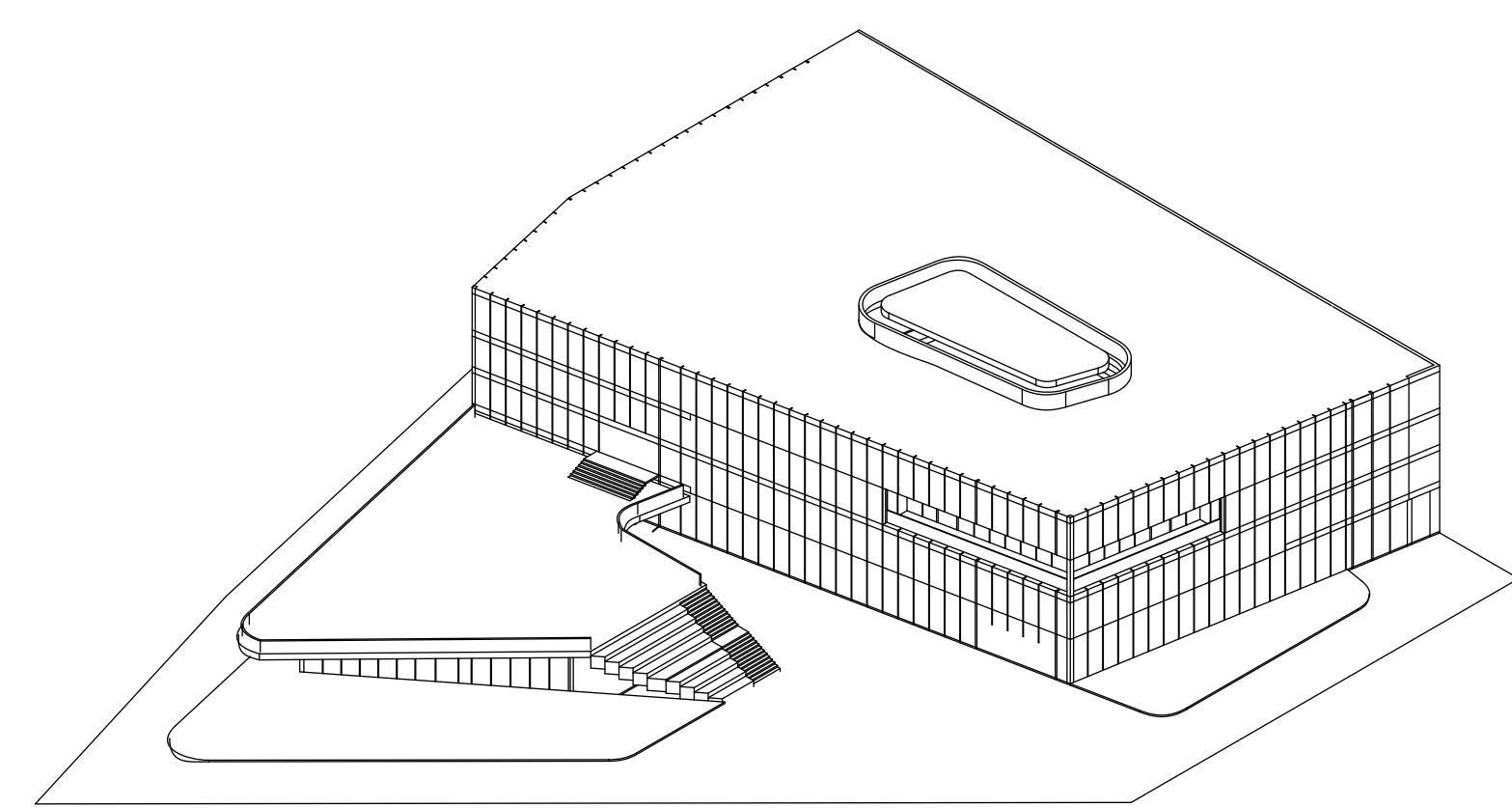
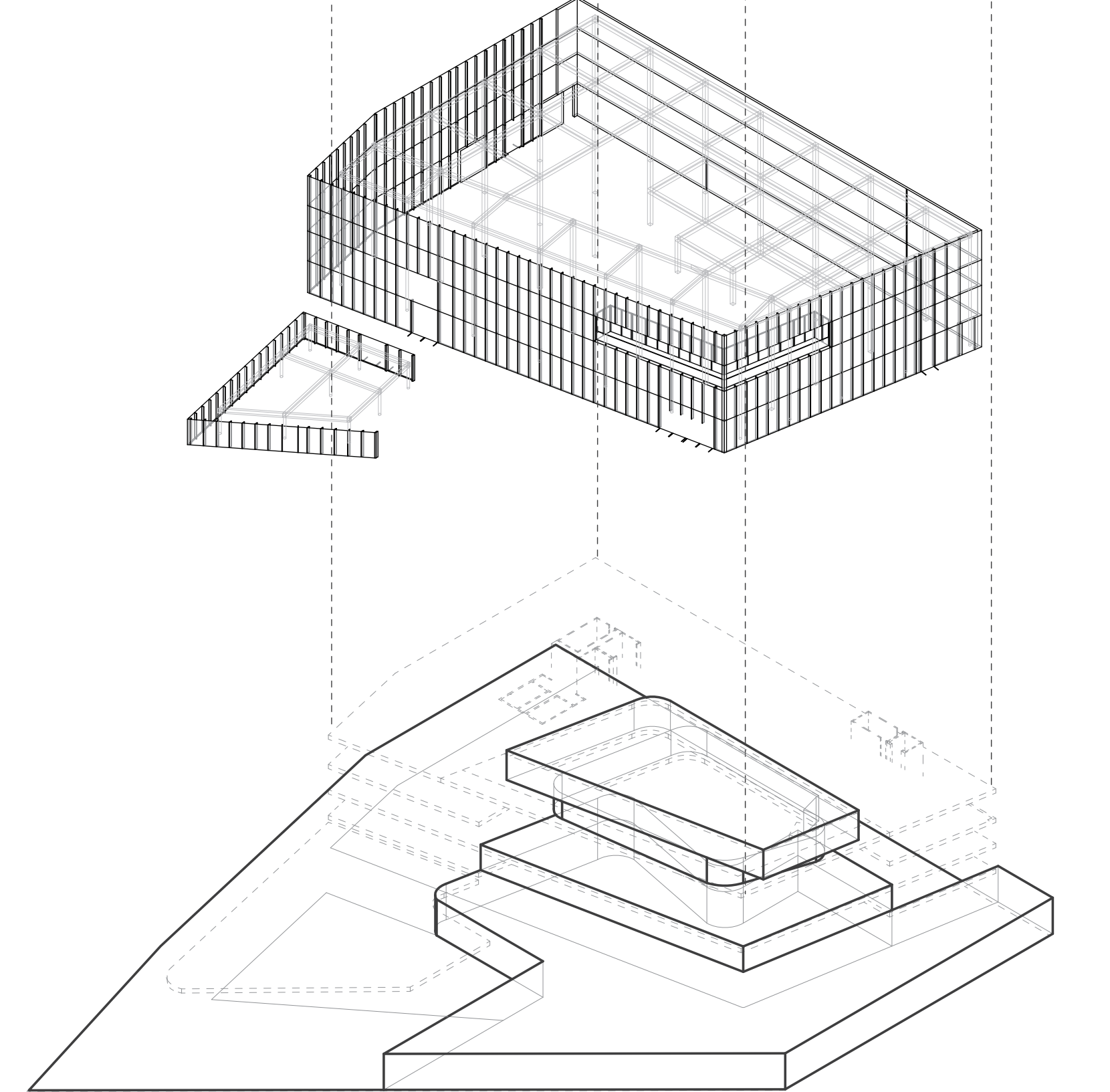
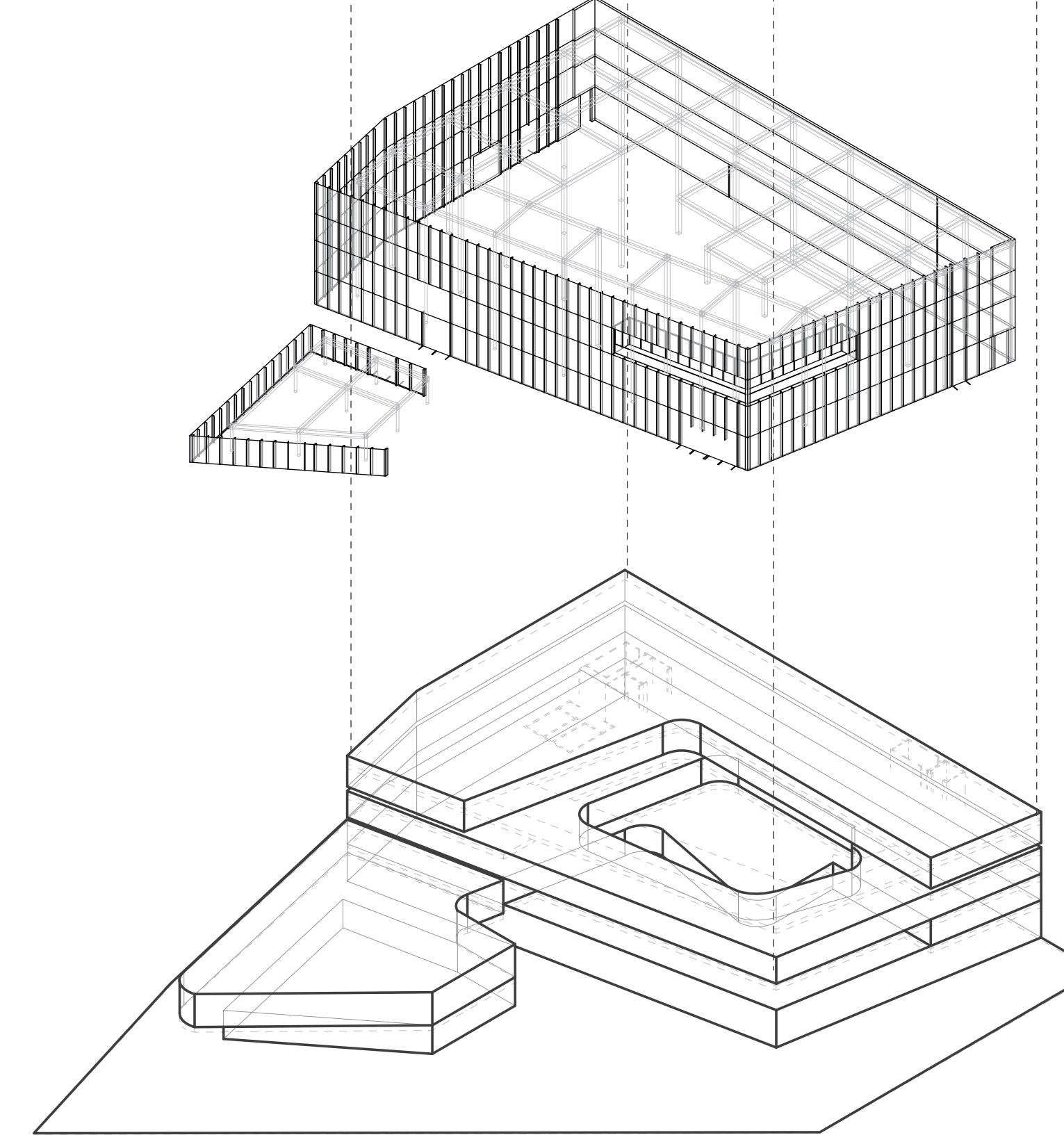
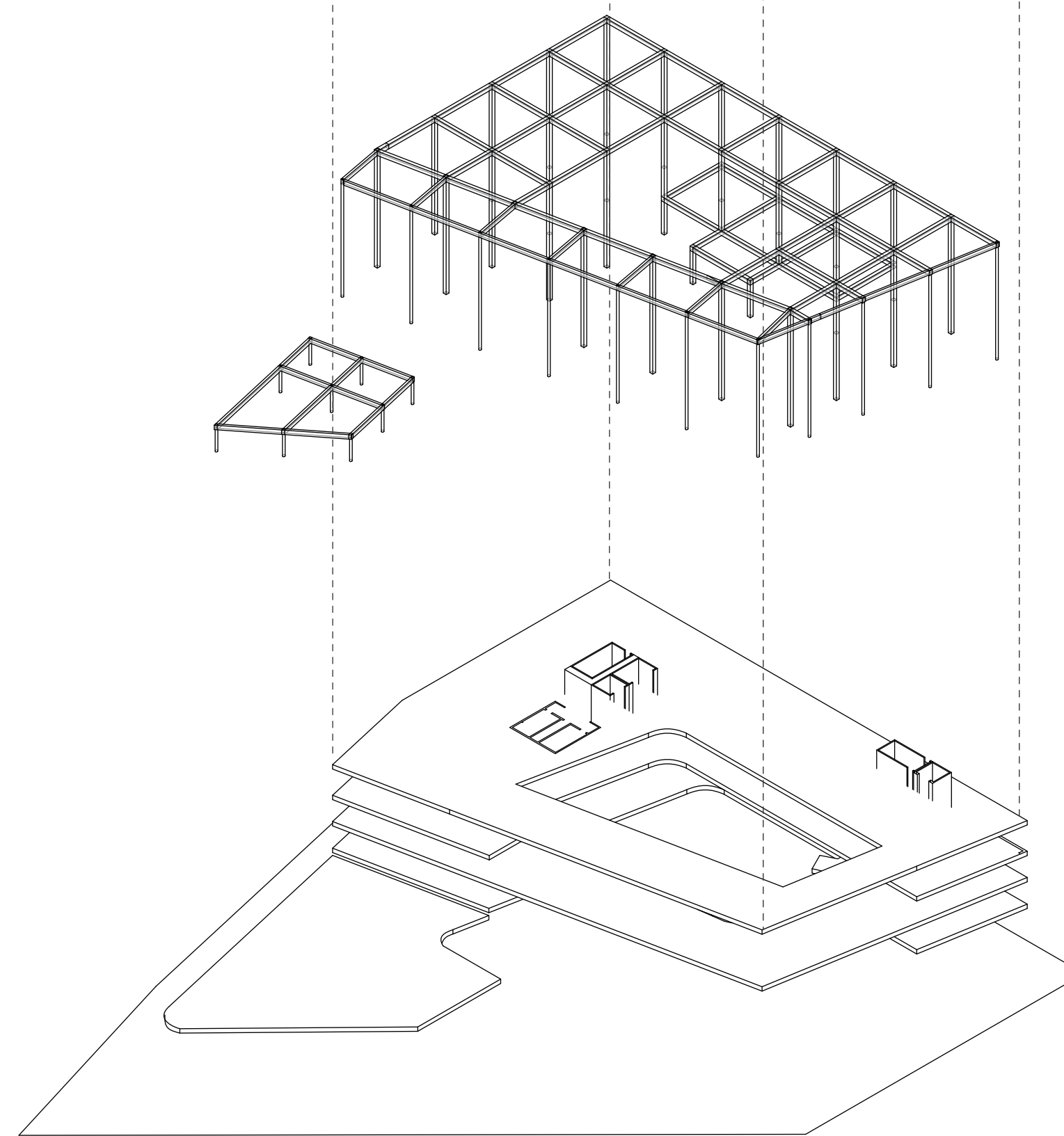
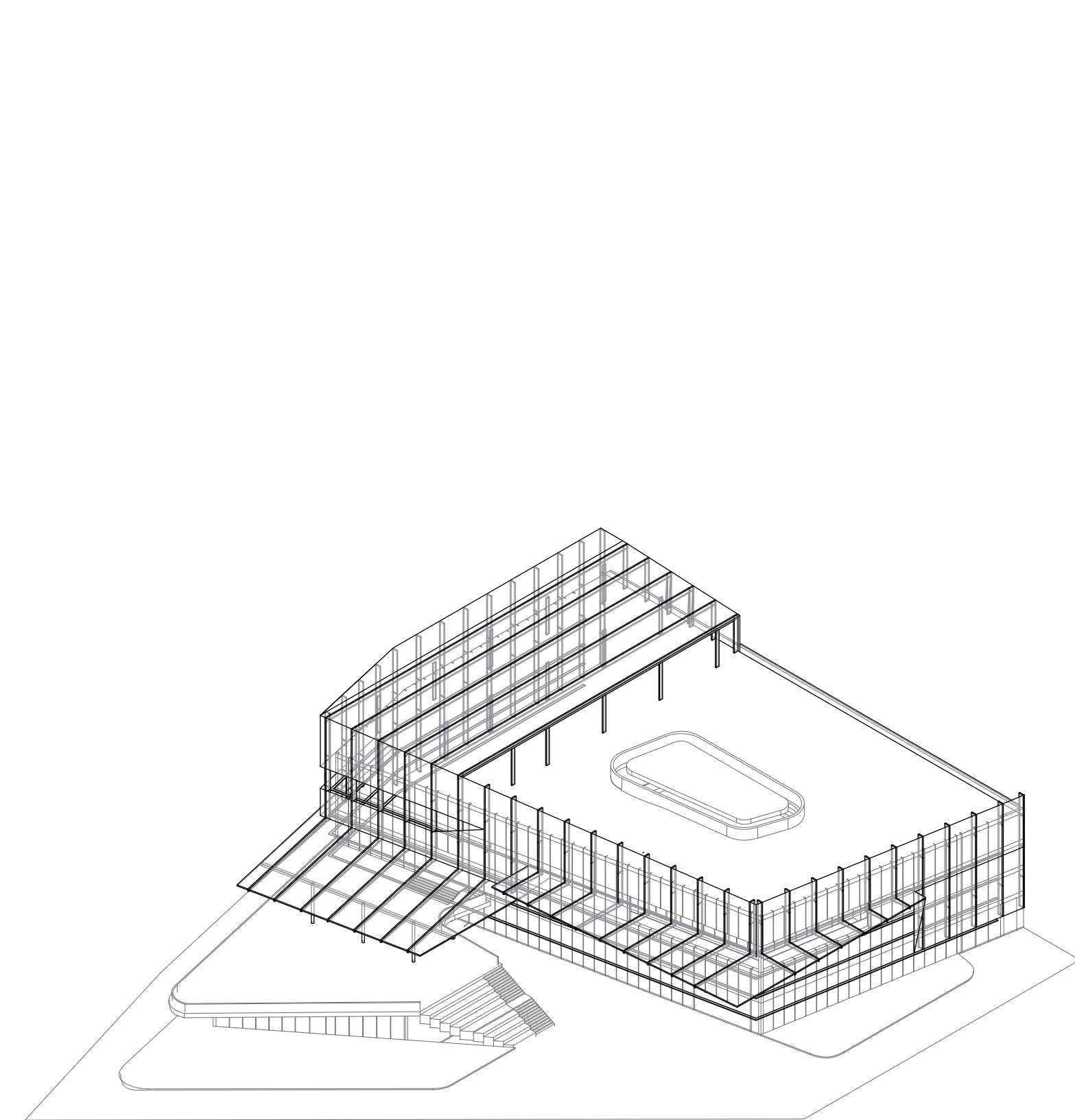
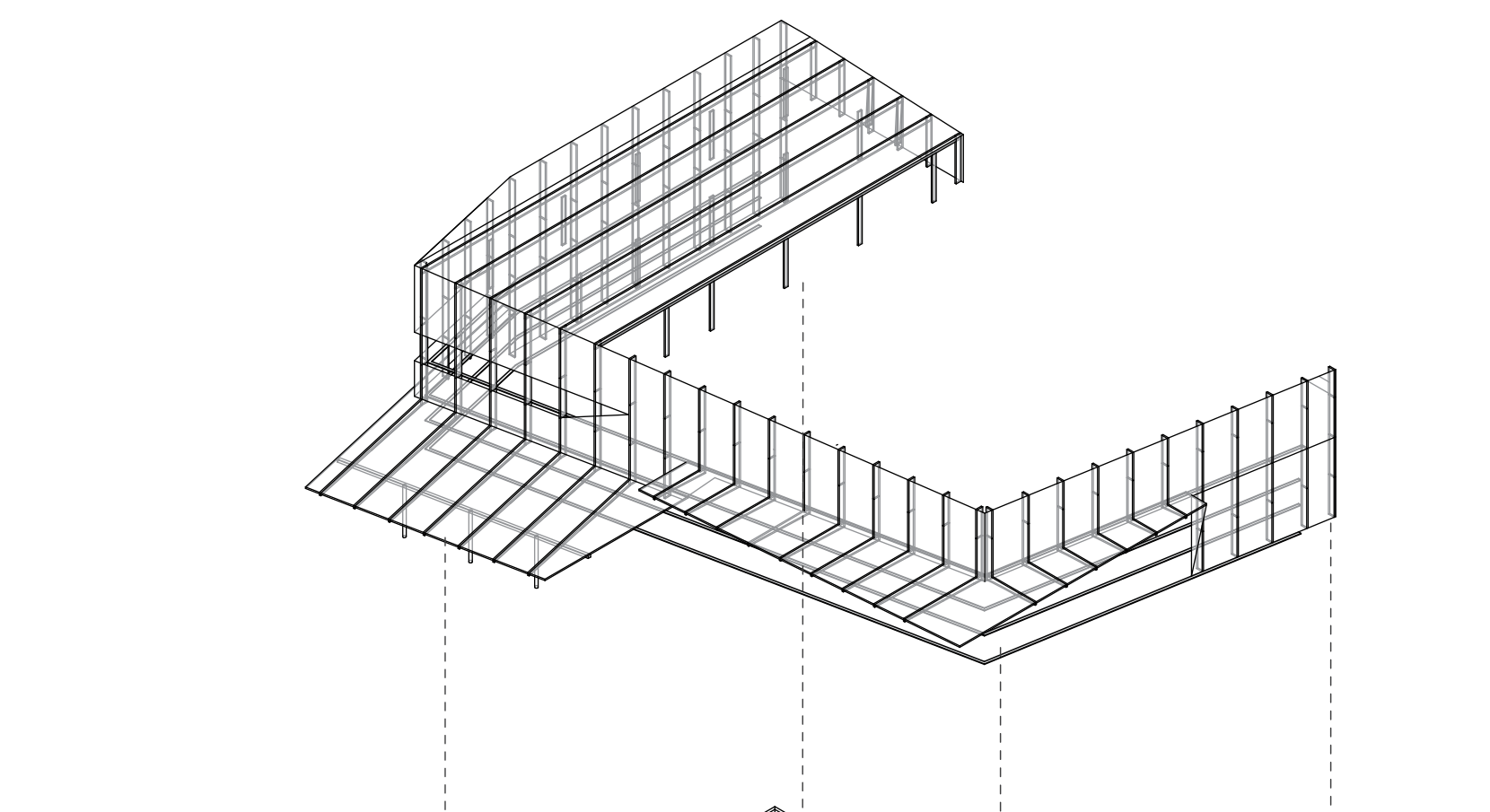
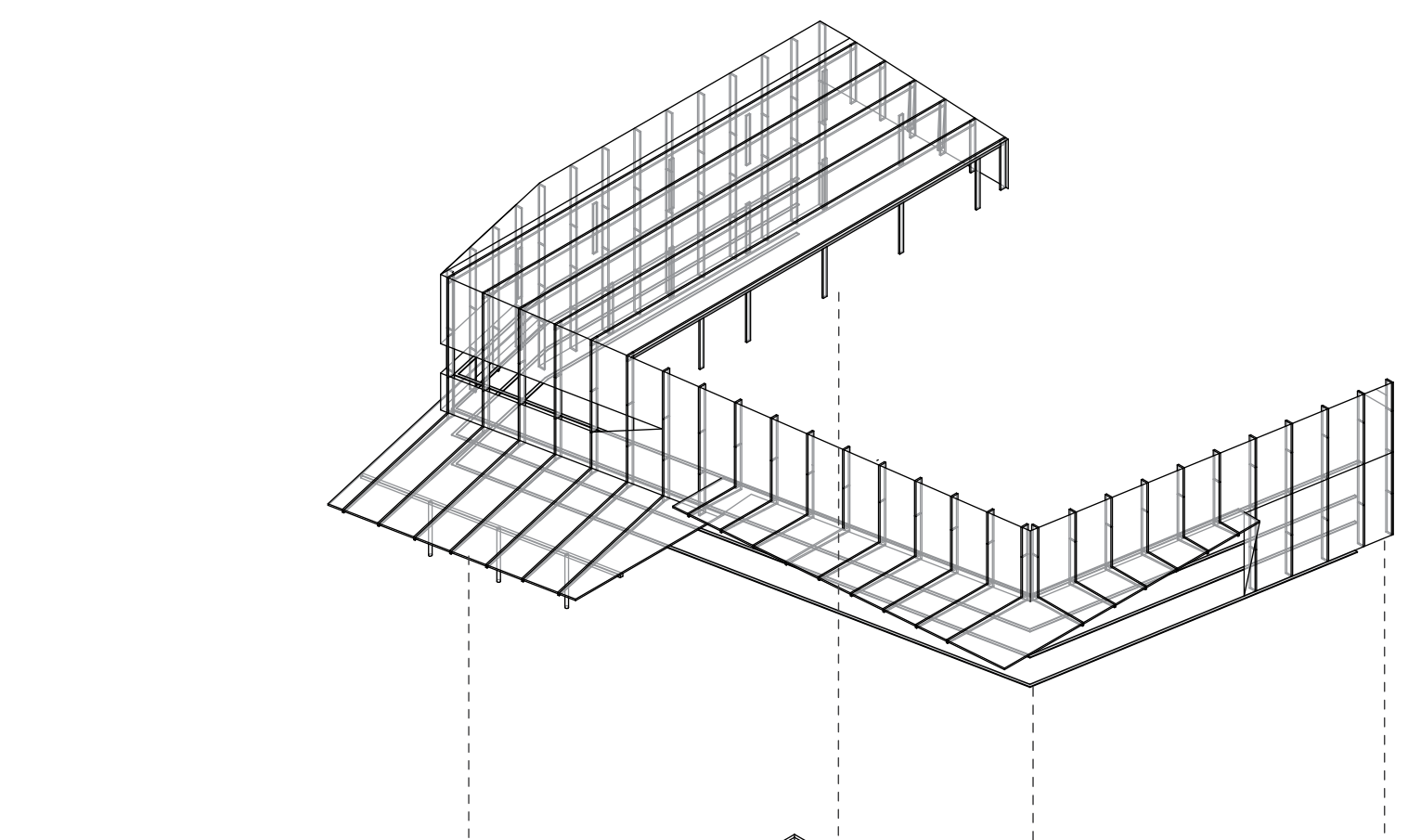
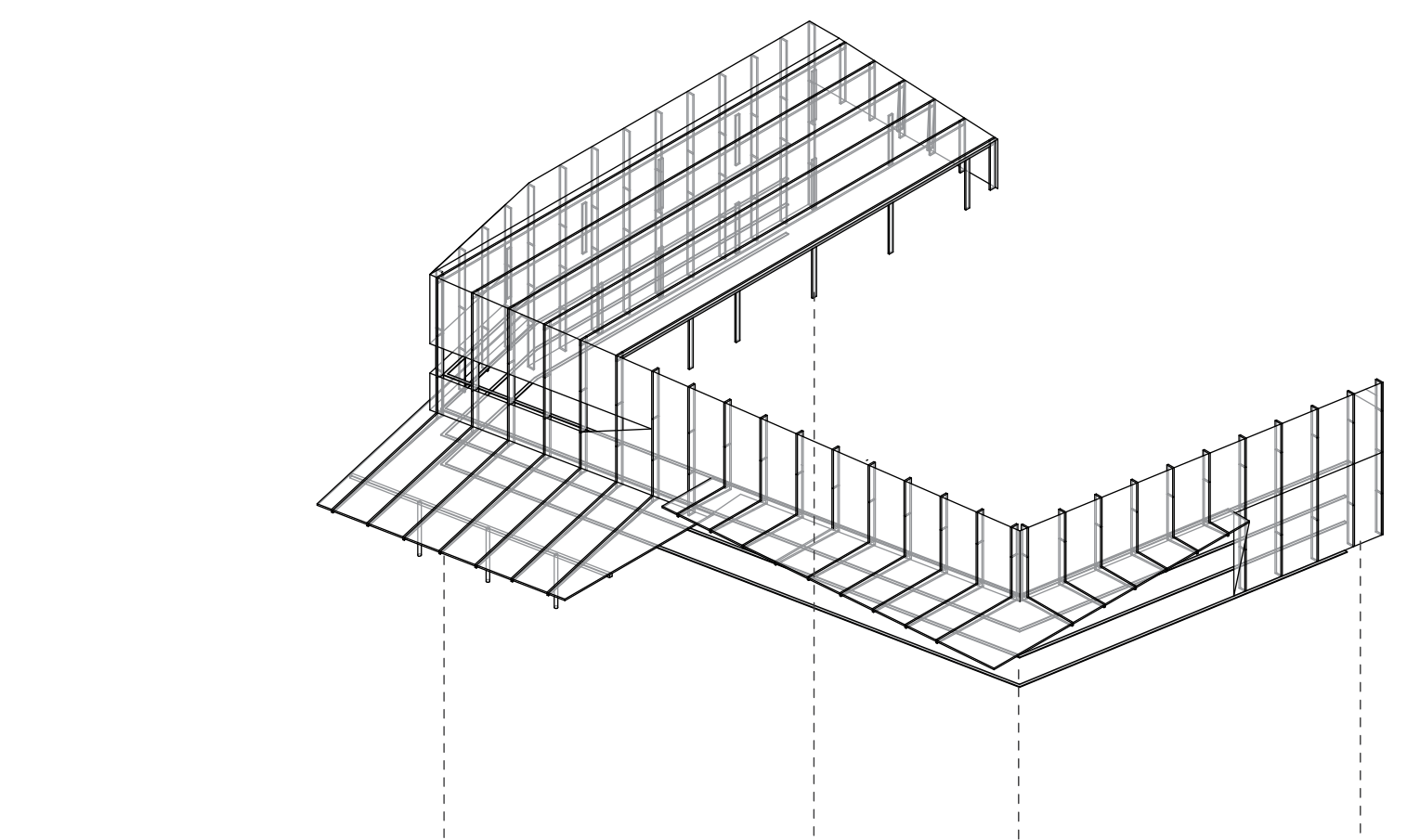
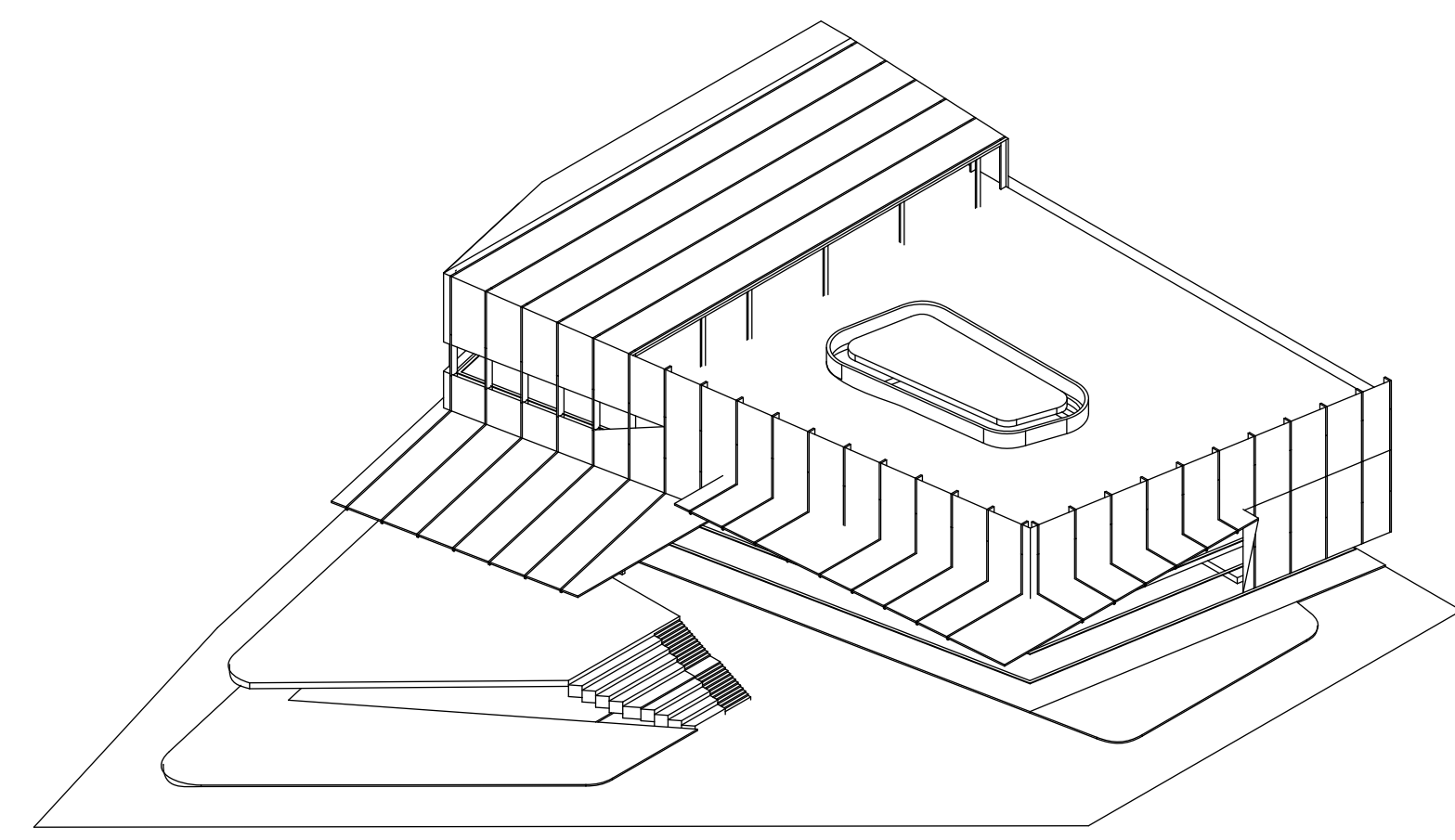

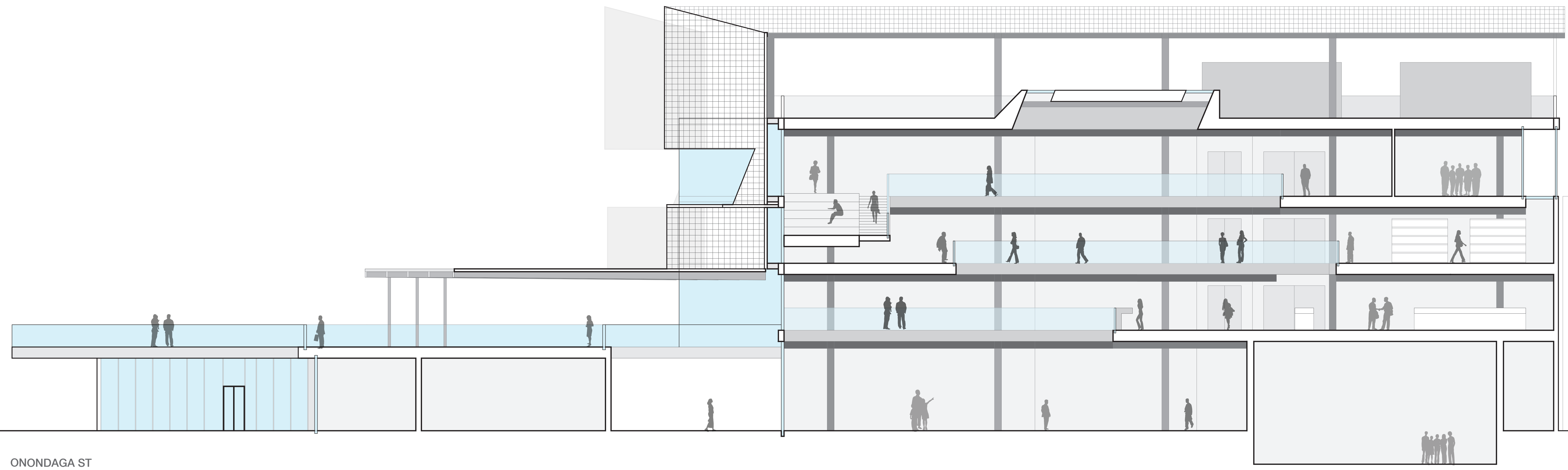
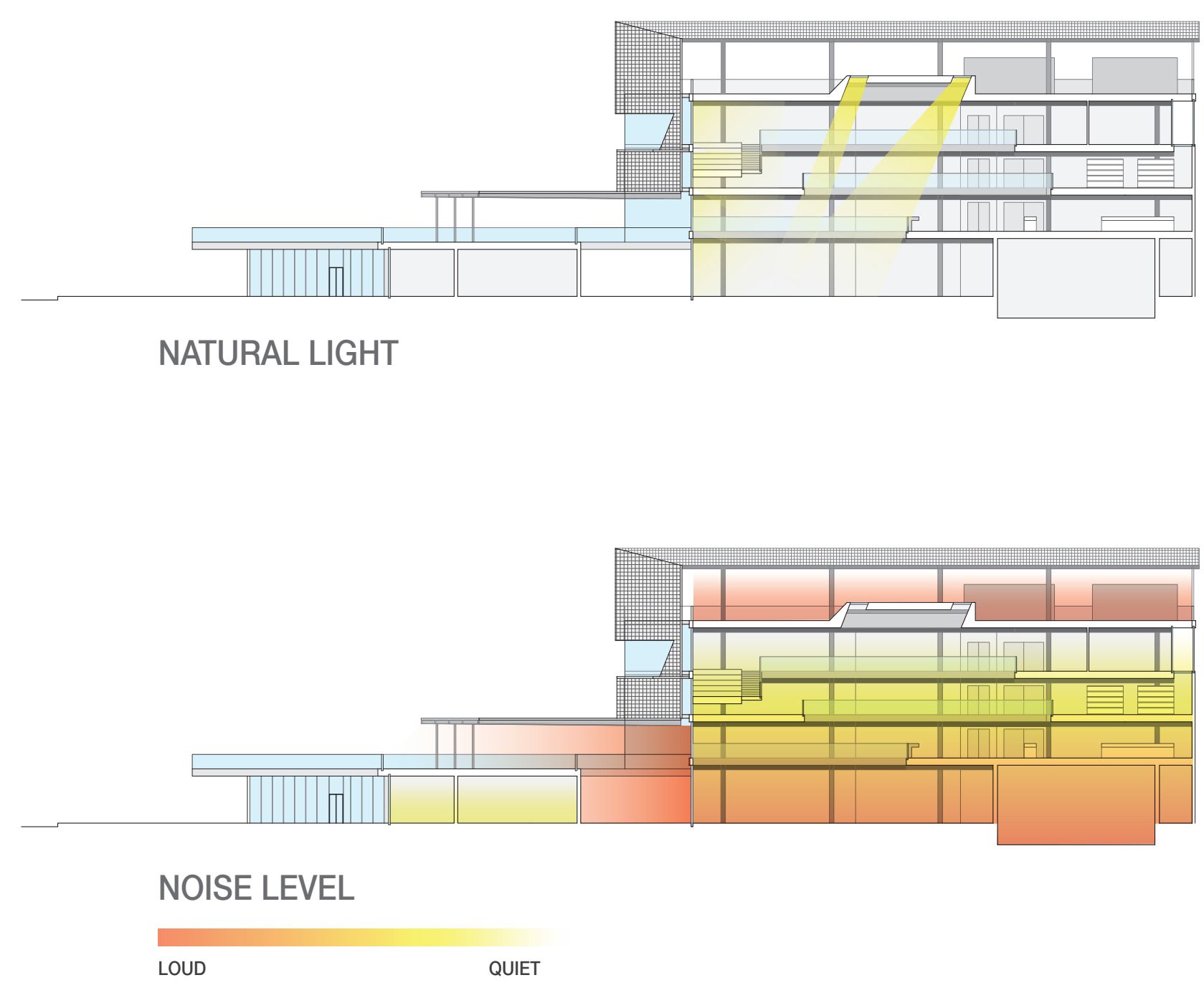

SECTION B
1/8" SCALE

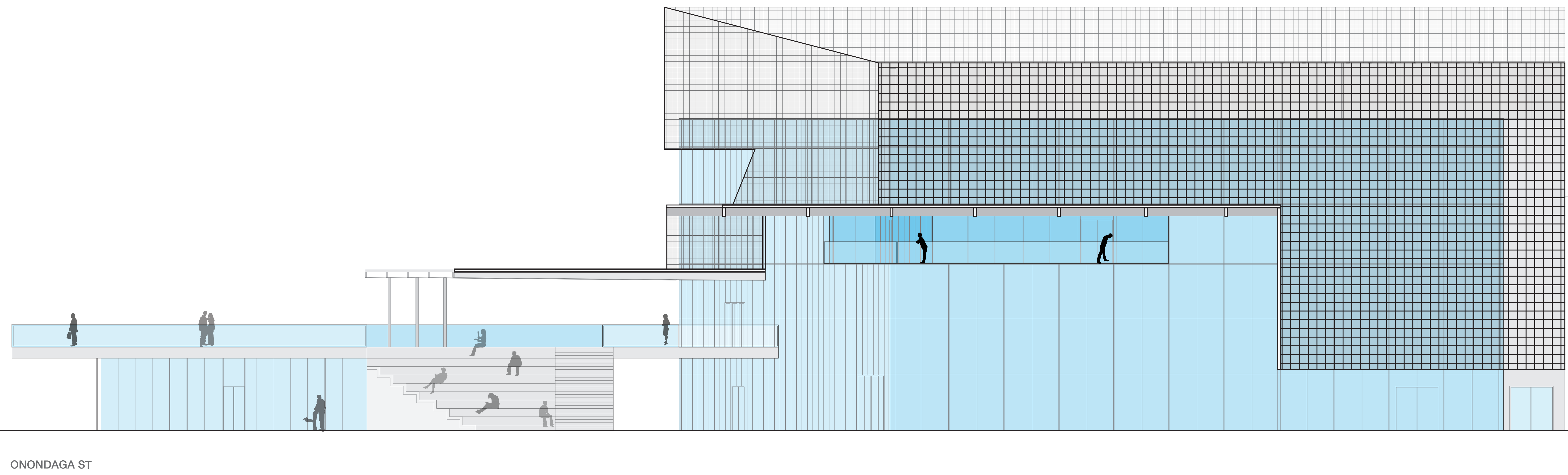
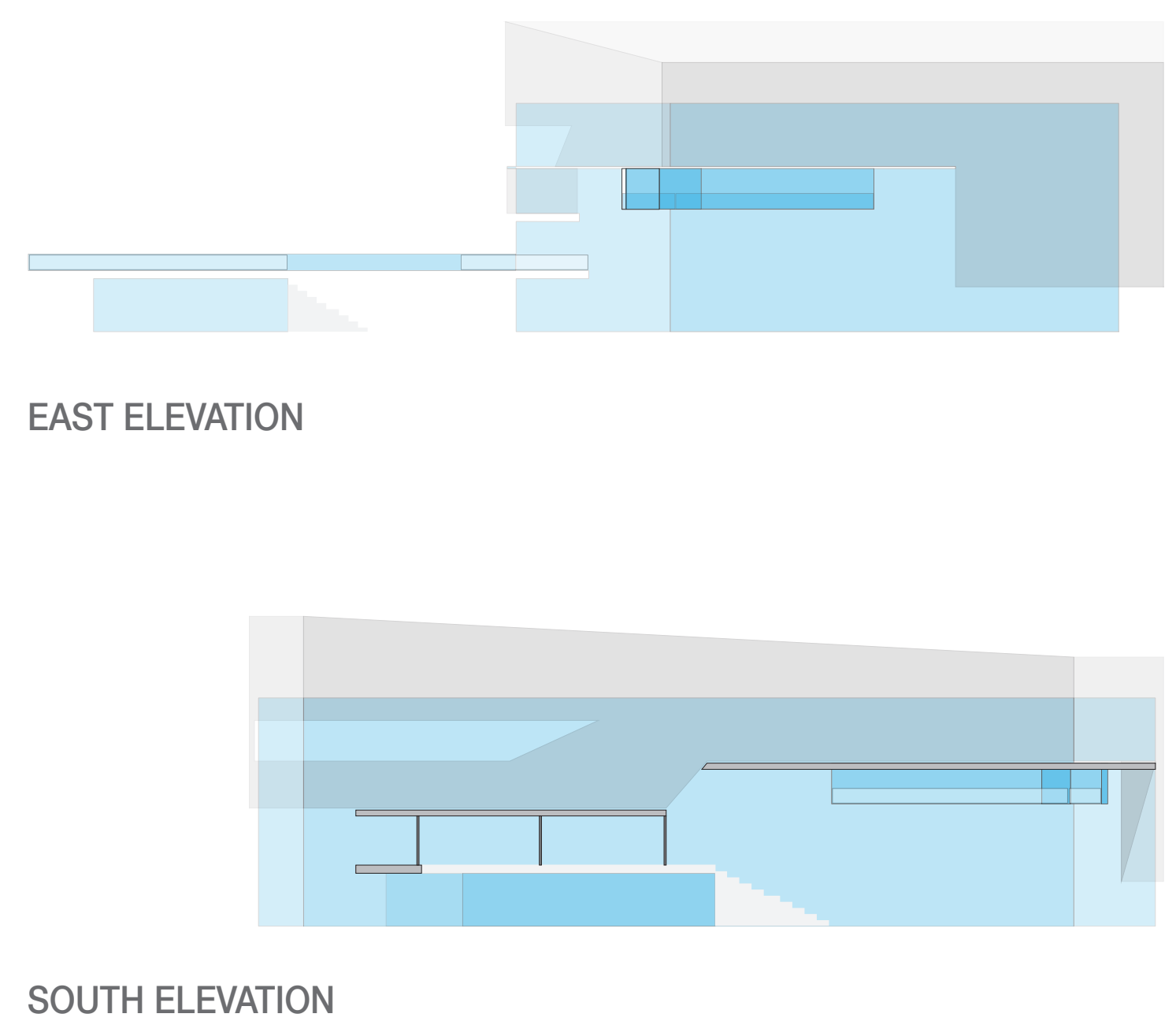

EAST ELEVATION
1/8" SCALE

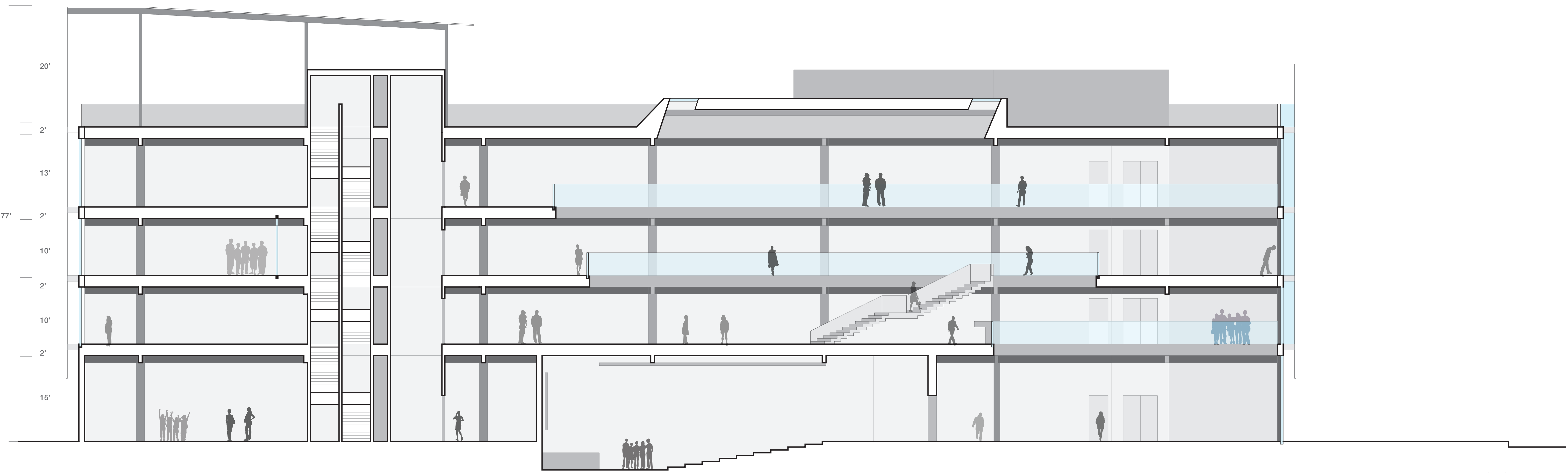

SECTION A
1/8' SCALE

ONONDAGA ST

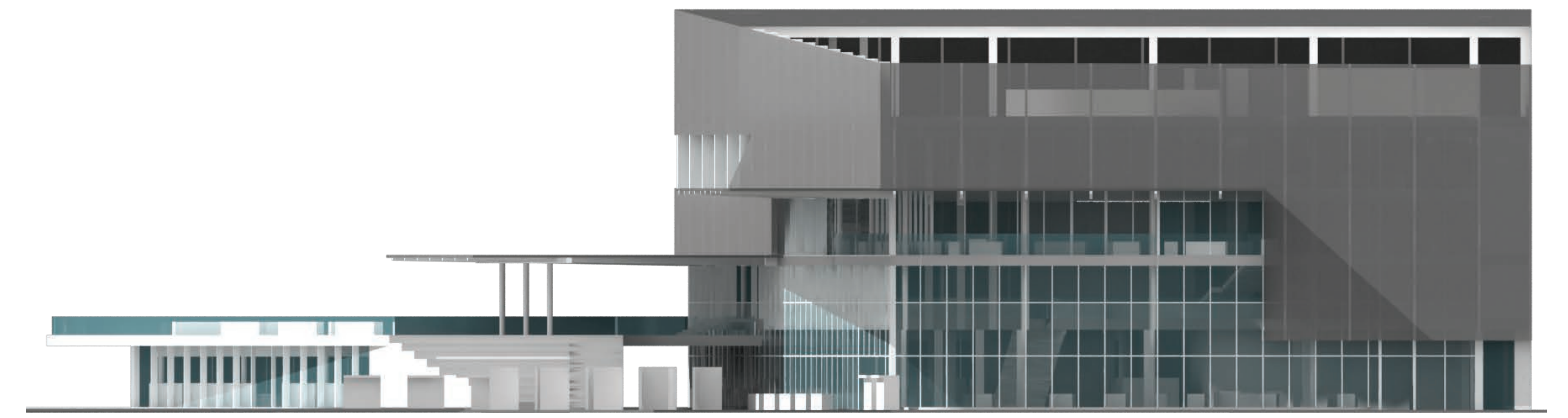

EAST ELEVATION

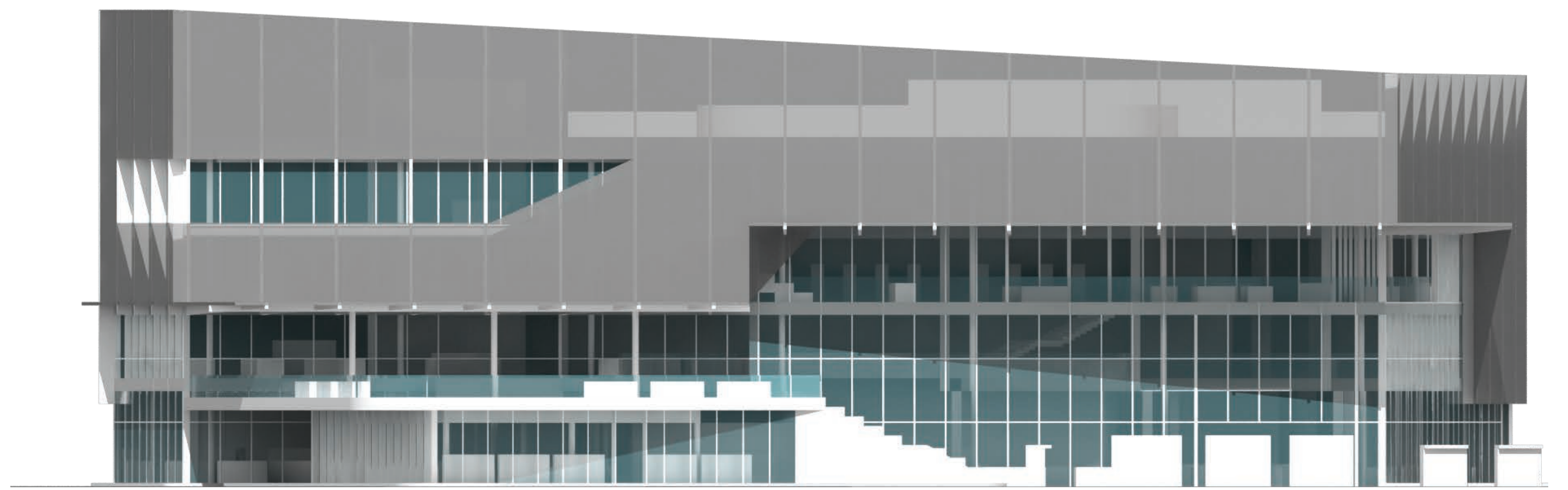

SOUTH ELEVATION

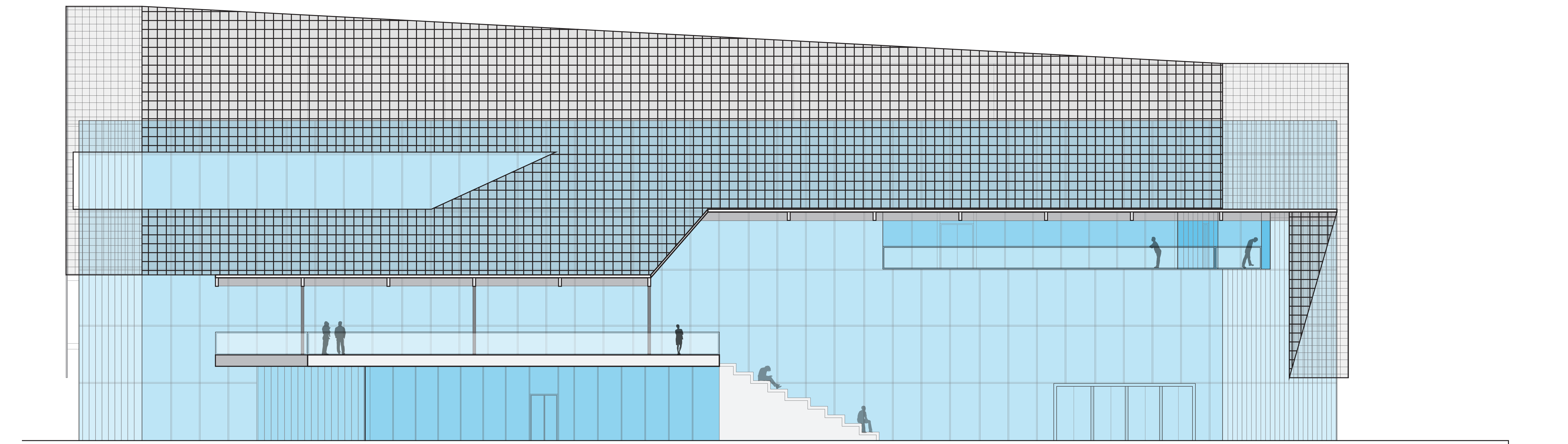

SOUTH ELEVATION
1/8' SCALE

ONONDAGA ST

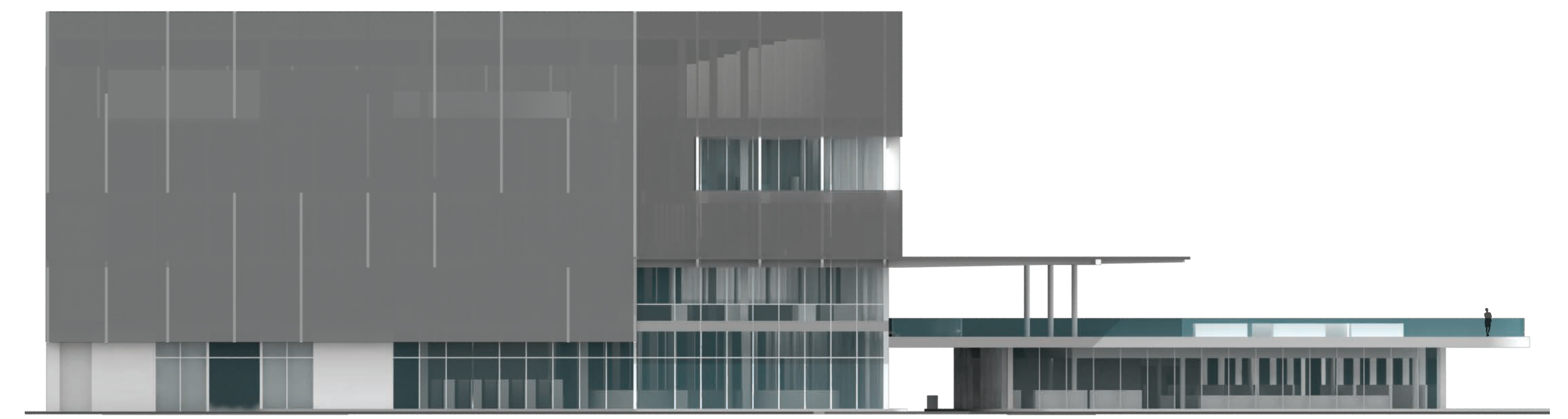

WEST ELEVATION



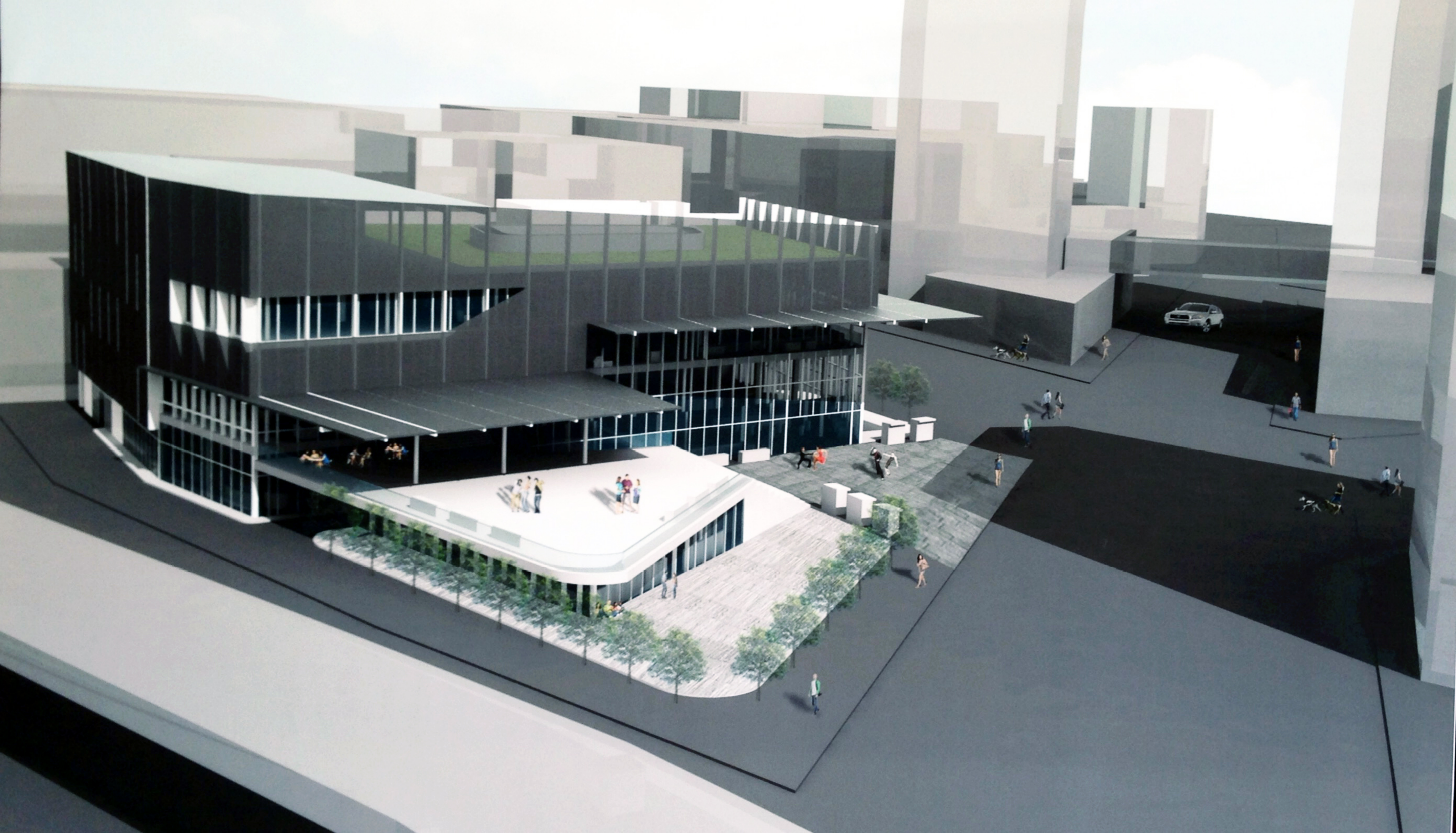



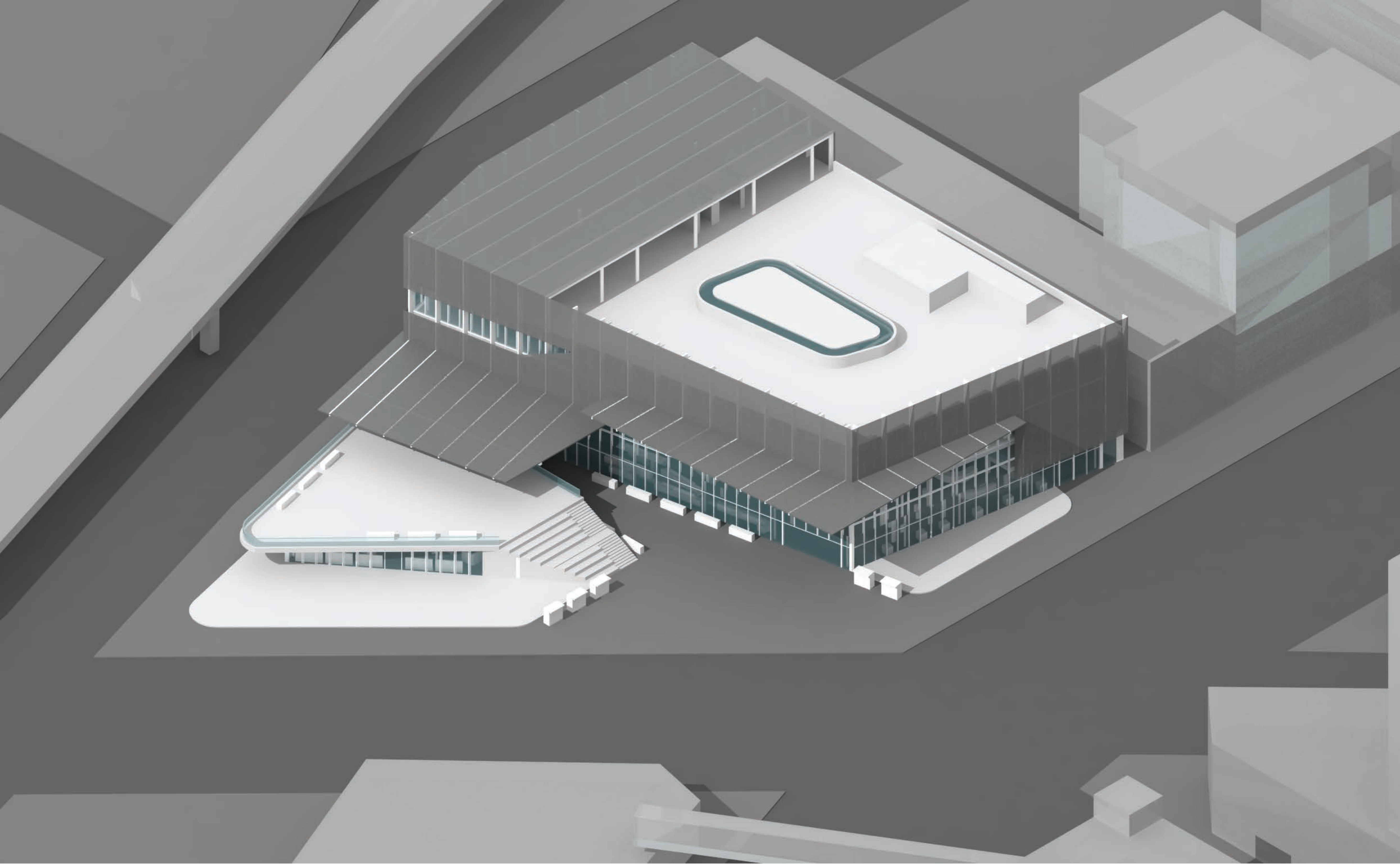

SOUTH EAST ISOMETRIC



NORTH EAST ISOMETRIC

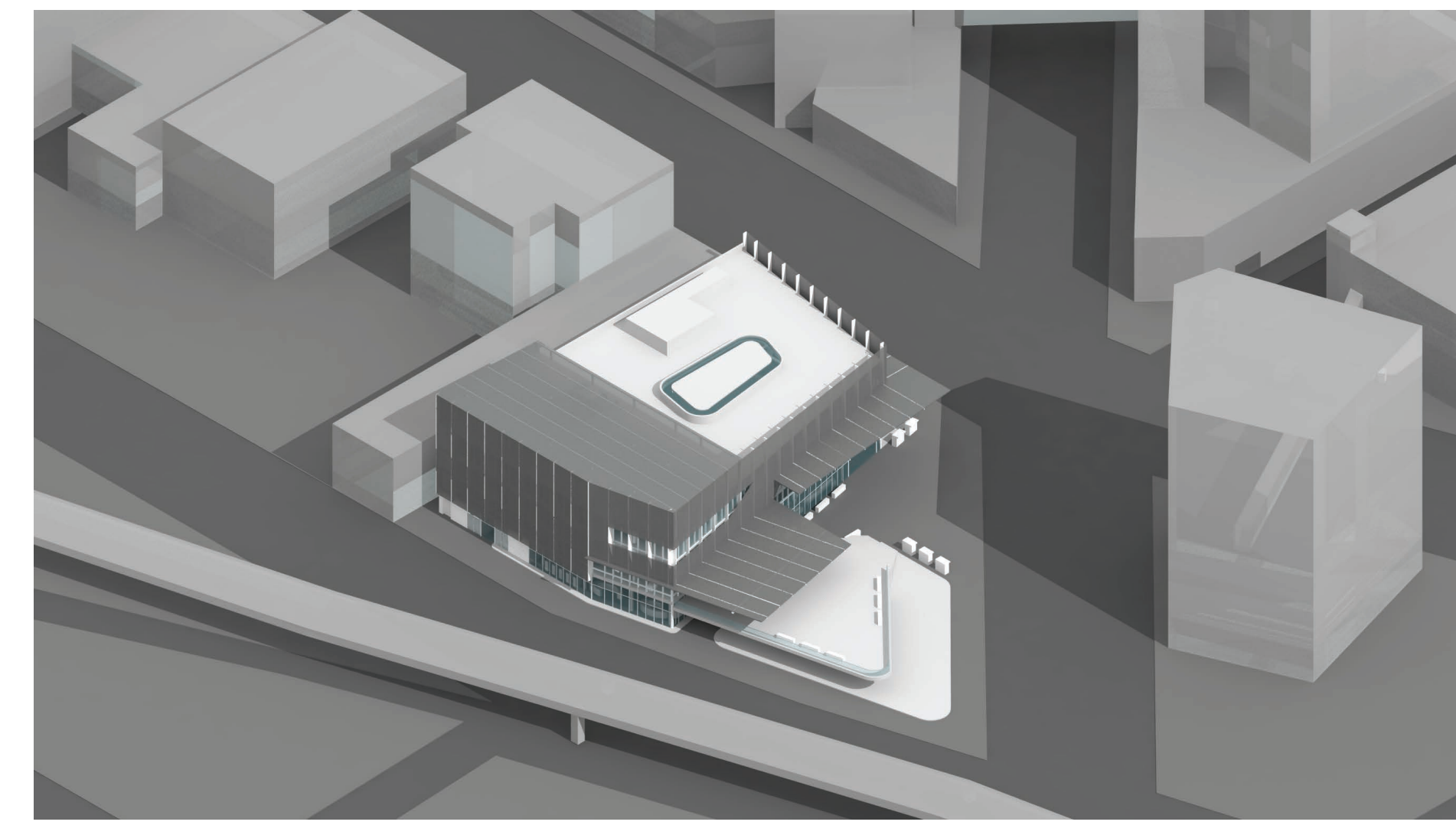

SOUTH WEST ISOMETRIC



GROUND LEVEL



SECOND LEVEL



THIRD LEVEL



FOURTH LEVEL

