

Syracuse University

**SURFACE**

---

Physics

College of Arts and Sciences

---

8-4-2005

## Isobar Rescattering Model and Light Scalar Mesons

Joseph Schechter

*Department of Physics, Syracuse University, Syracuse, NY*

Follow this and additional works at: <https://surface.syr.edu/phy>



Part of the [Physics Commons](#)

---

### Recommended Citation

Schechter, Joseph, "Isobar Rescattering Model and Light Scalar Mesons" (2005). *Physics*. 271.  
<https://surface.syr.edu/phy/271>

This Article is brought to you for free and open access by the College of Arts and Sciences at SURFACE. It has been accepted for inclusion in Physics by an authorized administrator of SURFACE. For more information, please contact [surface@syr.edu](mailto:surface@syr.edu).

## ISOBAR RESCATTERING MODEL AND LIGHT SCALAR MESONS

J. SCHECHTER

*Physics Department,  
Syracuse University,  
Syracuse, NY 13244-1130, USA.  
E-mail: schechte@phy.syr.edu*

We use a toy model to discuss the problem of parameterizing the possible contribution of a light scalar meson, sigma, to the final state interactions in the non leptonic decays of heavy mesons.

Keywords: Dalitz diagram; Chiral symmetry; Rescattering.

PACS numbers: 12.39.Fe, 13.75.Lb

### 1. Introduction

A nice feature of recent results from BABAR, BELLE, CESAR and FERMI-LAB is the historically unprecedented number of points in the Dalitz diagrams obtained for decays like  $D^0 \rightarrow \pi^+ \pi^- \bar{K}_0$ . It is not only favorable for learning more about CP violation and associated problems in the weak interactions but for learning about properties of resonances in the strong interactions. This involves a resonance dominated description<sup>1</sup> (so-called isobar model) as illustrated in Fig. 1. Typically, a Breit-Wigner shape as well as an arbitrary overall complex number is assumed for each resonance. While it is hard to rigorously justify such a procedure from fundamental QCD, it is made plausible by the large  $N_C$  approximation<sup>2</sup> which actually suggests that such a procedure should hold when the resonances are quark anti-quark composites. Of course, this kind of procedure has worked very well in the past for many established resonances like the  $\rho(770)$ .

Recently, there has been a great deal of interest (See ref<sup>3</sup>-ref<sup>7</sup>) in the possibility of observing the seemingly elusive light scalar mesons, like the sigma ( $f_0(600)$ ) and its strange analog, kappa, from such Dalitz diagrams. Evidence for their existence had been previously obtained by many workers

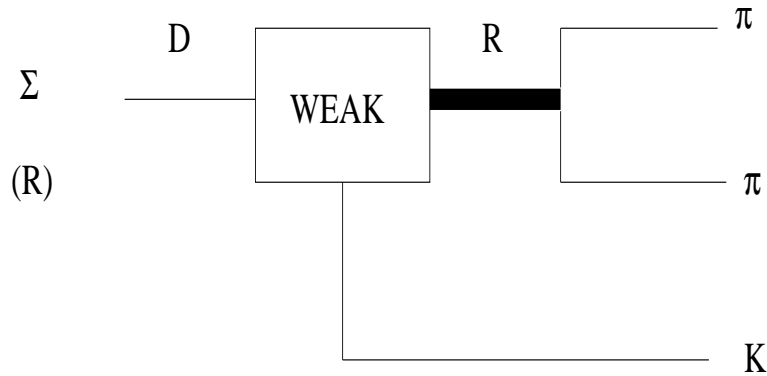

### + Strange resonance contributions

Figure 1. Isobar model for the decay  $D \rightarrow \pi\pi\bar{K}$

based on constructing theoretical models and comparing with experimentally obtained phase shifts. This evidence suggests that these resonances are “hidden”- they do not have obvious Breit Wigner shapes but seem to contain a lot of interference with the background. Furthermore, their structure seems more likely to be two quarks- two antiquarks rather than quark-antiquark; this is deduced from the fact that, when amalgamated in a putative  $SU(3)$  nonet, they display an upside-down ordering with the degenerate iso-singlet, isotriplet states ( $f_0(980)$ ,  $a_0(980)$ ) appearing as heaviest rather than lightest members. It should be noted that such a “four quark” structure is theoretically disfavored for resonances in the leading tree order of the large  $N_c$  approximation. So, on both experimental and theoretical grounds, one may expect that the parameterization of these possible resonances in the Dalitz analysis might very well be different from the parameterization of ordinary quark- antiquark resonances.

What is the crucial ingredient in a suitable parameterization of low energy scalar resonances? We will argue that it is chiral symmetry.

## 2. Chiral symmetry

The problem of the scalar channel in pion physics goes back about fifty years. Using the Yukawa (pion exchange) model, the value of the pi-nucleon

coupling constant,  $g_{\pi NN}$  was well established from the long distance behavior of the nucleon-nucleon potential. However, when this value of coupling constant was applied to try to calculate the s-wave pion nucleon scattering length using the nucleon exchange diagrams, the answer turned out to be more than ten times larger than experiment. The cure was eventually realized to involve upgrading the iso-spin or SU(2) symmetry to two separate iso-spin symmetries for the left and right handed components of the nucleon. This chiral SU(2) symmetry would be manifest if the nucleons were massless. However, Nambu had the insight to propose that the symmetry is there anyway and that the nucleon receives a mass because the symmetry is “spontaneously broken”. The simplest realization of this mechanism is embodied in the Gell Mann - Levy linear sigma model<sup>8</sup>. The chiral symmetry meson multiplet in this model contains, in addition to the pions, a scalar particle denoted the sigma. When the mass of the sigma is considerably higher than the pion mass, the effect of sigma exchange cancels out almost all of the much too large result for the s-wave pion nucleon scattering and leaves the right answer.

The same situation prevails for the s-wave pion pion scattering amplitude. The meson part of the chiral invariant linear sigma model Lagrangian is given in terms of the pion and sigma fields as:

$$L = -\frac{1}{2}(\partial_\mu\pi \cdot \partial_\mu\pi + \partial_\mu\sigma\partial_\mu\sigma) + a(\sigma^2 + \pi^2) - b(\sigma^2 + \pi^2)^2, \quad (1)$$

where the real parameters  $a$  and  $b$  are both taken positive to insure spontaneous breakdown of chiral symmetry. The vacuum value  $\langle\sigma\rangle$  of the  $\sigma$  field is related to the pion decay constant as

$$F_\pi = \sqrt{2}\langle\sigma\rangle, \quad (2)$$

where  $F_\pi = 0.131$  GeV. The parameter  $a$  is given by

$$a = \frac{1}{4}m_{\sigma B}^2, \quad (3)$$

where  $m_{\sigma B}$  is the tree level (or bare) value of the sigma mass. The only unknown parameter at the moment in this simple model is  $m_{\sigma B}$  since one has  $b = m_{\sigma B}^2/(2F_\pi)^2$ . Then, calculating the conventional pion pion amplitude as the sum of the 4-point pion term plus the sigma exchange term gives the result,

$$A(s, t, u) = \frac{2(m_{\sigma B}^2 - m_\pi^2)}{F_\pi^2} \left[ \left(1 - \frac{s - m_\pi^2}{m_{\sigma B}^2 - m_\pi^2}\right)^{-1} - 1 \right]. \quad (4)$$

Here,  $s, t, u$  are the Mandelstam variables and we have included the effect of the small pion mass by adding a term linear in the field  $\sigma$  to Eq. (1).

The last entry “-1” in this equation represents the 4 point pion term. Near threshold ( $s = 4m_\pi^2$ ) and for  $m_{\sigma B}^2$  large compared to  $m_\pi^2$ , most of this is seen to be canceled away and one is left with Weinberg’s formula<sup>9</sup> for near threshold scattering,

$$A(s, t, u) = \frac{2}{F_\pi^2}(s - m_\pi^2), \quad (5)$$

which works very well. The inelegant feature of the present derivation is that it arises as the near cancellation between two large quantities. This can be cured by “integrating out” the relatively heavy sigma (as was done for a different reason already by Gell Mann and Levy). Then the pion field appears non-linearly; this non-linear sigma model treats the interaction strength as properly “small” and is convenient to use for further calculations (Chiral perturbation theory program). However, we shall use the original linear model here since our purpose is to provide a simple toy model to illustrate how to parameterize the effects of the sigma meson. From the above we can already draw the lesson that a simple pole term for the sigma without the associated 4 pion contact term is likely to be misleading. Both are needed for the chiral symmetry to hold.

It is amusing that the SU(2) linear sigma model is identical to the Higgs sector of the standard electroweak theory when one scales up  $F_\pi$  by a factor of about 2660. The sigma becomes the Higgs particle and the pions become the longitudinal components of the W and Z bosons. Our present understanding of “precision” electroweak theory suggests that the quantity  $m_{\sigma B}$  scales up by a slightly reduced factor so that the dimensionless quantity  $b$  (which measures the strength of the Higgs self coupling) is smaller than for the possible low energy QCD application.

### 3. Pion pion scattering

The needed  $I=J=0$  partial wave amplitude for pi pi scattering at tree level is obtained from Eq. (4) as:

$$[T_0^0]_{\text{tree}}(s) = \alpha(s) + \frac{\beta(s)}{m_{\sigma B}^2 - s} \quad (6)$$

where

$$\alpha(s) = \frac{\sqrt{1 - \frac{4m_\pi^2}{s}}}{32\pi F_\pi^2} (m_{\sigma_B}^2 - m_\pi^2) \left[ -10 + 4 \frac{m_{\sigma_B}^2 - m_\pi^2}{s - 4m_\pi^2} \ln \left( \frac{m_{\sigma_B}^2 + s - 4m_\pi^2}{m_{\sigma_B}^2} \right) \right],$$

$$\beta(s) = \frac{3\sqrt{1 - \frac{4m_\pi^2}{s}}}{16\pi F_\pi^2} (m_{\sigma_B}^2 - m_\pi^2)^2. \quad (7)$$

The normalization of the amplitude  $T_0^0(s)$  is given by its relation to the partial wave S-matrix

$$S_0^0(s) = 1 + 2iT_0^0(s). \quad (8)$$

While, as just discussed, this tree-level formula works well at threshold it does involve large coupling constants and cannot be expected to be a priori reasonable even several hundred MeV above threshold. In addition, at the point  $s = m_{\sigma_B}^2$ , the amplitude Eq. (6) diverges. The solution to this problem, which is adopted in the conventional isobar rescattering parameterizations, is to include a phenomenological width term in the denominator by making the replacement:

$$\frac{1}{m_{\sigma_B}^2 - s} \longrightarrow \frac{1}{m_{\sigma_B}^2 - s - im_{\sigma_B}\Gamma}. \quad (9)$$

However this standard approach is not a good idea in the present case. As emphasized by Achasov and Shestakov<sup>10</sup>, the replacement Eq. (9) completely destroys the good threshold result which is a consequence of chiral symmetry. This is readily understandable since the threshold result was seen to arise from a nearly complete cancellation between the first and second terms of Eq. (6). However, the pole in the linear sigma model can be successfully handled by using, instead of Eq. (9), K-matrix regularization, which instructs us to adopt the exactly unitary form

$$S_0^0(s) = \frac{1 + i [T_0^0]_{\text{tree}}(s)}{1 - i [T_0^0]_{\text{tree}}(s)} \quad (10)$$

Using Eq. (8) we get

$$T_0^0(s) = \frac{[T_0^0]_{\text{tree}}(s)}{1 - i [T_0^0]_{\text{tree}}(s)}. \quad (11)$$

Near threshold, where  $[T_0^0]_{\text{tree}}(s)$  is small, this reduces to  $[T_0^0]_{\text{tree}}(s)$  as desired. Elsewhere it provides a unitarization of the theory which is seen to have the general structure of a “bubble-sum”. We will adopt this amplitude

as our toy model for (the strongly coupled) QCD in the low energy I=J=0 channel.

The obvious question is whether this toy model can explain the experimental data. The only parameter available is  $m_{\sigma B}$ . In Fig. 2 the real part of the  $T_0^0$  amplitude (sufficient in the elastic regime) is plotted against existing data for several values of  $m_{\sigma B}$ . It is seen that there is at least a rough fit to the data up till about 0.8 GeV if  $m_{\sigma B}$  lies in the range 0.8 - 1.0 GeV. Clearly, the energy region between about 0.8 and 1.2 GeV is not at all fit by the model. However this is due to the neglect of a second scalar resonance which is expected to exist in low energy QCD. As shown in <sup>11</sup> if the SU(2) Lagrangian is “upgraded” to the three-flavor case (so that another scalar field  $\sigma'$  identifiable with the  $f_0(980)$  is contained) the entire region up to about  $\sqrt{s} = 1.2$  GeV can be reasonably fit with the same K matrix unitarization scheme.

In assessing the validity of this toy model for low energy QCD one should also consider the role of the vector mesons. These are known to be important in many low energy processes and give the dominant contributions to the “low energy constants” of the chiral perturbation theory expansion. Nevertheless it was found <sup>12</sup> that, while rho meson exchange does make a contribution to low energy s-wave pion pion scattering, its inclusion does not qualitatively change the properties of the light  $\sigma$  resonance which seems crucial to explain the I=J=0 partial wave. More specifically, the effect of the rho meson raises the  $\sigma$  mass by about 100 MeV and lowers its width somewhat.

Thus, we have seen that the given toy model provides a reasonable description of low energy s-wave pion pion scattering. At the same time we have seen a couple of its drawbacks and how to improve them. Before going to the rescattering application, it seems worthwhile to mention an interesting feature of the K-matrix unitarization. The criterion for the model to be in the non-perturbative region is that the dimensionless coupling constant  $b = \left(\frac{m_{\sigma B}}{2F_\pi}\right)^2$  is greater than unity. Here  $b$  is around 10. Thus one might expect the physical parameters like the sigma mass and width to differ from their “bare” or tree-level values. To study this we look at the complex sigma pole position in the partial wave amplitude in Eqs. (11) and (7):

$$T_0^0(s) = \frac{(m_{\sigma B}^2 - s)\alpha(s) + \beta(s)}{(m_{\sigma B}^2 - s)[1 - i\alpha(s)] - i\beta(s)}. \quad (12)$$

This is regarded as a function of the complex variable  $z$  which agrees with

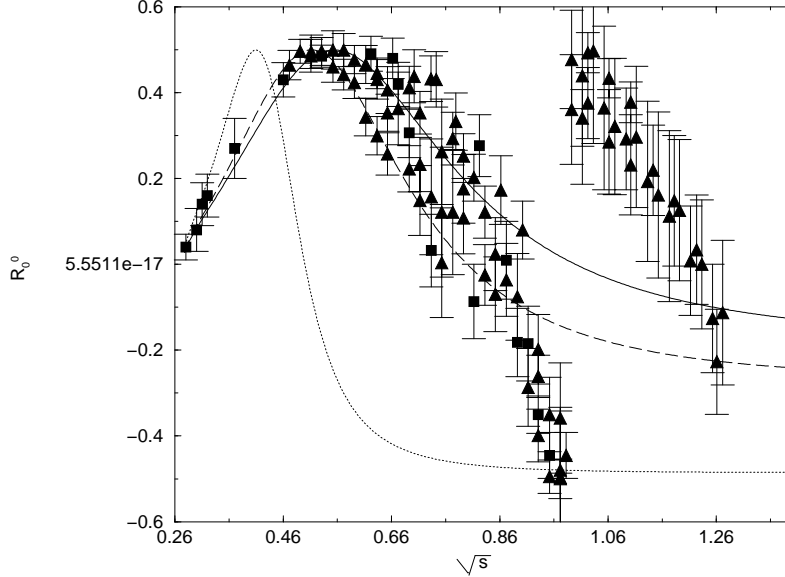

Figure 2. Comparison with experiment of Real part of the  $I=J=0$   $\pi\pi$  scattering amplitude in the SU(2) Linear Sigma Model, for  $m_{\sigma B} = 0.5$  GeV (dots),  $m_{\sigma B} = 0.8$  GeV (dashes) and  $m_{\sigma B} = 1$  GeV (solid). Experimental data<sup>13</sup> are extracted from Alekseeva *et al* (squares) and Grayer *et al* (triangles).

$s + i\epsilon$  in the physical limit. The pole position  $z_0$  is then given as the solution of:

$$(m_{\sigma B}^2 - z_0)[1 - i\alpha(z_0)] - i\beta(z_0) = 0. \quad (13)$$

Note that  $\alpha(s)$  remains finite as  $q^2 = s - 4m_\pi^2 \rightarrow 0$ , so there are no poles due to the numerator of Eq. (12). In Fig. 3 we show how  $\sqrt{\text{Re}(z_0)}$ , a measure of the “physical” sigma mass, depends on the choice of  $m_{\sigma B}$ . Note that there is a maximum physical mass and correspondingly two different values of  $m_{\sigma B}$  will result in the same physical mass. In fact, the best fit value lies a bit to the right of the peak; there the physical mass is considerably less than the bare mass. Similarly, the physical width comes out considerably smaller than the bare width.

It is amusing to observe that the peak of  $|T_0^0(s)|$  occurs at the bare sigma mass,  $s = m_{\sigma B}^2$ . This may be seen by noting that, since  $T_0^0(s)$  can be expressed in terms of the phase shift as  $\exp(i\delta_0^0(s)) \sin \delta_0^0(s)$ , the peak will occur where  $|\delta_0^0(s)| = \pi/2$ . In other words, the peak will occur where  $T_0^0(s)$



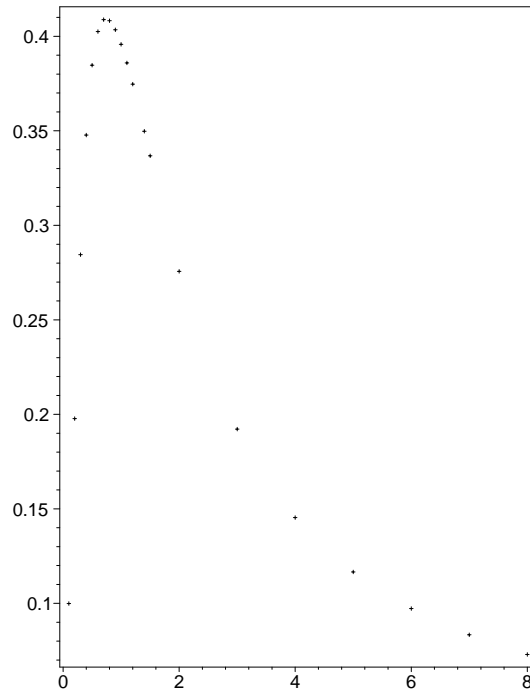

Figure 3. Plot of  $\sqrt{\text{Re}(z_0)}$  in GeV as a function of  $m_{\sigma B}$  in GeV. Here we have set  $m_\pi = 0$ .

is pure imaginary. This is immediately seen from Eq (12) to be the case when  $s = m_{\sigma B}^2$ . It should also be remarked that the shape of  $|T_0^0(s)|$  differs considerably from a corresponding Breit-Wigner shape for the parameter choice which fits the s-wave pion pion scattering data.

#### 4. Rescattering

We have argued against using for the rescattering term representing the sigma in Fig. 1, the usual choice:

$$\frac{g_{\sigma\pi\pi}}{m_{\sigma B}^2 - s - im_{\sigma B}\Gamma}, \quad (14)$$

where  $g_{\sigma\pi\pi}$  is the sigma pi pi coupling constant in the model (which will anyway get absorbed in an unspecified “production” factor). In the K-matrix unitarization we do not introduce the width by hand. Rather the rescattering is represented by the “bubble sum” factor  $(1 - i[T_0^0]_{tree})^{-1}$  as

in Eq. (11). Then, the proper rescattering factor <sup>10</sup> is,

$$\frac{g_{\sigma\pi\pi}}{m_{\sigma B}^2 - s} \frac{1}{1 - i[T_0^0]_{\text{tree}}} = \frac{g_{\sigma\pi\pi}}{m_{\sigma B}^2 - s} \cos \delta_0^0 \exp i\delta_0^0, \quad (15)$$

where we used the relation for the phase shift  $\delta_0^0$  in the K-matrix unitarization scheme:  $\tan \delta_0^0 = [T_0^0]_{\text{tree}}$ , where in turn the unitarized I=J=0 S-matrix element is given by  $S_0^0 = \exp 2i\delta_0^0$ . It is important to examine the quantity  $\cos \delta_0^0(s)$ . Using Eq. (6) it is straightforward to find

$$\cos \delta_0^0(s) = \frac{m_{\sigma B}^2 - s}{[(m_{\sigma B}^2 - s)^2 + (\alpha(s)(m_{\sigma B}^2 - s) + \beta(s))^2]^{1/2}}. \quad (16)$$

The numerator cancels the pole at  $s = m_{\sigma B}^2$  in Eq. (15) so one has a finite result for the rescattering factor expressed in terms of the functions  $\alpha(s)$  and  $\beta(s)$  defined in Eq.(7). In contrast to  $|T_0^0|$ , the magnitude of the rescattering factor  $|\cos \delta_0^0 e^{i\delta_0^0} / (m_{\sigma B}^2 - s)|$  peaks at the much smaller physical value rather than the bare value of the sigma mass <sup>14</sup>. This is understandable since there is a trivial numerator and the denominator has the same structure as the denominator used to find the physical pole position.

To sum up, we have stressed that it is necessary to take chiral symmetry into account when parameterizing the final state rescattering into two pions in the I=J=0 channel. We presented a simple toy model <sup>15</sup> which seems able to do the job. In this model the quantity  $m_{\sigma B}$  may be considered a parameter. Evidently there is a lot more to do in this area and hopefully the possibility of improving our understanding of low energy strong dynamics will emerge.

### Acknowledgments

This talk is mainly based on reinterpreting <sup>14</sup> which deals with production of longitudinal electroweak gauge bosons by the "gluon fusion" mechanism. More complete referencing is included there. I am happy to thank my collaborators A. Abdel-Rehim, D. Black, A. H. Fariborz, M. Harada, R. Jora, S. Moussa, S. Nasri and F. Sannino for many exciting discussions. Amir Fariborz deserves a vote of thanks for excellently organizing this stimulating conference. An earlier version of the talk was presented at the BaBar Dalitz Workshop (SLAC, Dec. 5, 2004) and I am grateful to B. Meadows and A. Palano for inviting me to that interesting event. The talk was written up at the University of Valencia; I sincerely thank J. W. F. Valle and his colleagues there for providing gracious hospitality and a stimulating

physics environment. The work was supported in part by the U. S. DOE under Contract no. DE-FG-02-85ER 40231.

### References

1. See, for example, D. M. Asner et al, arXiv:hep-ex/0311033.
2. G.'t Hooft, Nucl. Phys. **B72**, 461 (1974); E. Witten, Nucl. Phys. **160**, 57 (1979).
3. E791 Collaboration, Phys. Rev. Lett. **89**, 121801 (2002).
4. CLEO Collaboration, Phys. Rev. Lett. **89**, 251802 (2002).
5. Belle Collaboration, arXiv:hep-ex/0308043.
6. BaBar Collaboration, arXiv:hep-ex/0408088.
7. J. A. Oller, arXiv:hep-ph/0411105.
8. M. Gell-Mann and M. Levy, Nuovo Cimento 16, 705 (1960).
9. S. Weinberg Phys. Rev. Lett. **18**, 188 (1967).
10. N.N. Achasov and G.N. Shestakov, Phys. Rev. **D49**, 5779 (1994).
11. D. Black, A.H. Fariborz, S. Moussa, S. Nasri and J. Schechter, Phys. Rev. D **64**, 014031 (2001).
12. M. Harada, F. Sannino and J. Schechter, Phys. Rev. Lett. **78**, 1603 (1997).
13. E.A. Alekseeva *et al.*, Sov. Phys. JETP **55**, 591 (1982), G. Grayer *et al.*, Nucl. Phys. **B75**, 189 (1974).
14. A. Abdel-Rehim, D. Black, A. H. Fariborz, S. Nasri and J. Schechter, Phys. Rev. D **68**, 013008 (2003).
15. We argued that the sigma meson is likely to be an exotic resonance with a four quark structure, which does not appear as a pole at leading order in the  $1/N_c$  approximation. However, in the linear sigma model it is the chiral partner of the pion and hence presumably a p wave quark antiquark state. As far as the  $1/N_c$  expansion is concerned, it should then appear at leading order. We can explain this feature by saying that the bare sigma in the model is heavy and as such not apparently relevant for dynamics below 1 GeV. However, the unitarization, which has the effect of emphasizing the two meson (or four quark) component, is a sub leading large  $N_c$  feature which is important in lowering the bare sigma mass in our world of  $N_c = 3$ . In addition there is another effect which seems to push in the same direction. It has been argued that in the linear sigma model approach it is better to start with two chiral fields- one representing bare two quark states and the other bare four quark states. The low lying scalars in this picture tend to have relatively large four quark components. See section V of <sup>11</sup> above, M. Napsuciale and S. Rodriguez, arXiv:hep-ph/0407037 and A. H. Fariborz, R. Jora and J. Schechter, arXiv:hep-ph/0506170.