

7th International Building Physics Conference

IBPC2018

Proceedings

SYRACUSE, NY, USA

September 23 - 26, 2018

Healthy, Intelligent and Resilient
Buildings and Urban Environments

ibpc2018.org | [#ibpc2018](https://twitter.com/ibpc2018)



Experimental investigations of wooden beam ends in masonry with internal insulation: results contrasting three years of the experiment

Pavel Kopecký¹, Kamil Staněk¹, Michal Bureš¹, Jan Richter¹, Jan Tywoniak¹

¹University Centre for Energy Efficient Buildings, Třinecká 1024, Buštěhrad, Czech Republic

**Corresponding email: pavel.kopecky@fsv.cvut.cz*

ABSTRACT

This paper deals with hygro-thermal performance of wooden beam ends embedded in masonry walls with lime-cement plaster applied on the external side. Three different insulation systems are attached on the internal side of masonry. The real scale experiment has been monitored for three consecutive years. Microclimatic conditions in joist pockets were assessed by VTT mold growth index. The paper shows the influence of two changes of boundary conditions on the microclimate in joist pockets. First, moisture load on the internal side of building enclosure was increased (24 °C, 60 % in winter 2016/2017 instead 20 °C, 50 % in winter 2015/2016). Then, the artificial short-time rain event brought liquid water onto the external surface of building enclosure in July 2017. The rain intensity was chosen so as to mimic the intensive summer thunderstorm. The increase of water vapor concentration in the air on the internal side led to suitable conditions for mold growth in unsealed joist pockets of a vapor open insulation system. On contrary, microclimate in sealed joist pockets in both vapor open and vapor closed insulation systems stayed in acceptable levels with no mold growth. The artificial rain event significantly changed the hygro-thermal performance of joist pockets. Drying season was shortened and the relative humidity in joist pockets overtook the time profile of external relative humidity.

KEYWORDS

internal insulation, wooden beam end, monitoring, moisture safety, mould growth

INTRODUCTION

Uninsulated brick buildings suffer from high energy consumption, poor thermal comfort and mould growth on the coldest spots of the internal side of the building enclosure. Such buildings were erected before the Second World War in many European cities and often form entire neighborhoods. Floors are often supported by wooden beams placed in pockets embedded in brick walls. The external insulation is usually excluded from refurbishment measures, either because of the fixed building line or because of the decorative façade with cultural value. The internal insulation is therefore the only possible technical solution in these cases. However, the internal insulation significantly changes hygro-thermal performance of the masonry wall.

As the wooden beam protrudes out thermal insulation it is also located in the cold part of the building enclosure. The lower temperature in this position inevitably leads to higher relative humidity of the air in the joist pocket. Moisture content of wood in contact with the air in the pocket is therefore higher (as follows from the sorption isotherm) than it would be if wood was placed on the warm side of the building enclosure. If moisture content of wooden beam end is high enough for sufficient period of time, mold growth or even biodegradation can occur.

This paper deals with hygro-thermal conditions in the air cavity behind wooden beam ends placed in masonry pockets. To study this phenomena long-time full-scale experiments were built in University Center for Energy Efficient Buildings (UCEEB) of Czech Technical University in Prague. Boundary conditions, temperatures, relative humidity, moisture content in wood, and heat fluxes, have been continually recorded for three years. It is assessed whether microclimate of the joist pockets was suitable for mold growth on the wooden beam ends.

EXPERIMENTAL SETUP

Two “test windows” on the south west façade, with the dimension 3.0 m x 3.2 m each, are occupied by brick masonry walls (30 cm) with lime cement plaster (2 cm) on the external side. A climatic room with controlled internal environment is located on the internal side of test walls. Three different internal insulation systems are attached on the internal side of masonry: S1 - wood fiber insulation (8 cm, 14 cm) with thin plaster applied on the internal side (5 mm), S2 - soft mineral wool (9 cm) placed between aluminum studs with smart water vapor retarder and gypsum boards, S3 - vacuum insulation plates (2 cm) covered by EPS (2 × 1 cm) with thin internal plaster (5 mm). Joist pockets were treated by different means, see Fig. 1. For more details on the experimental setup see (Kopecký et al., 2016).

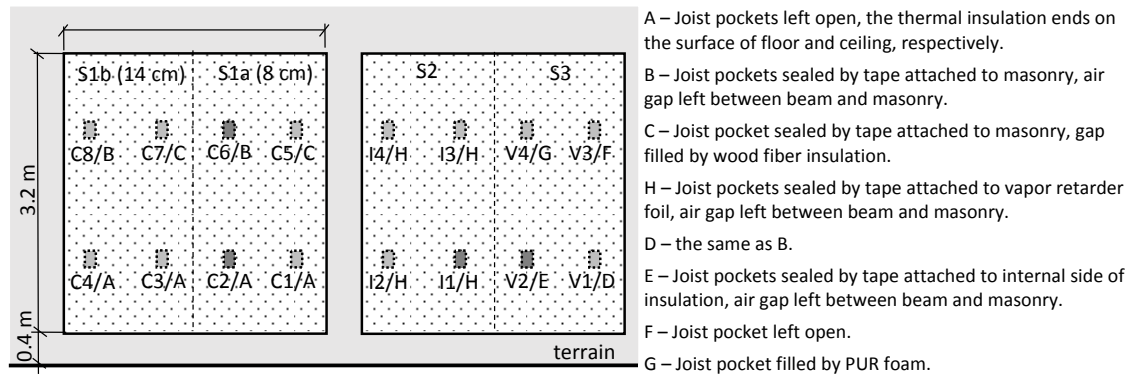

Figure 1. The view on the test fields (from exterior) with position of wooden beam ends.

The following sensors were used to monitor hygro-thermal conditions at the wooden beam end: 1) temperature sensors, 2) temperature + relative humidity sensors, 3) moisture content pins. Positions of the sensors are shown in Fig. 2. Thermostat and hygostat set points during the whole experiment are introduced in Fig. 3. The air handling unit is not equipped by dehumidifier. Therefore, the unit do not keep steady humidity during warm season.

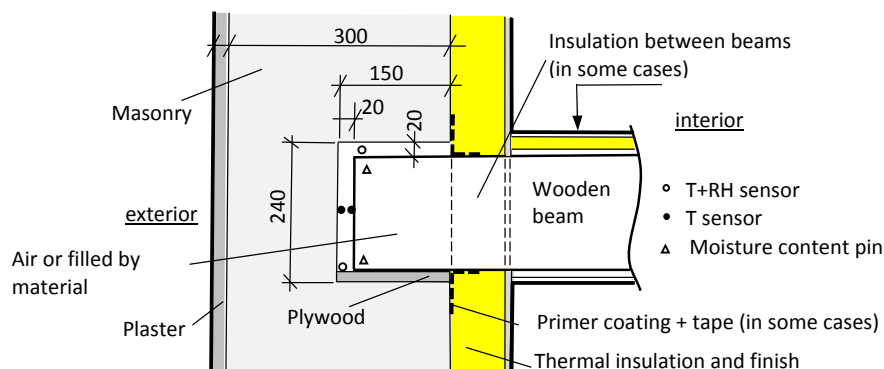

Figure 2. Position of measurement sensors in masonry pocket with wooden beam end.

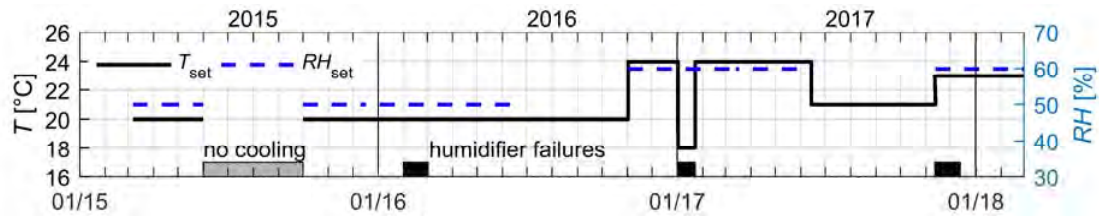

Figure 3. Thermostat and hygostat setpoints during experiment.

The artificial rain experiment was realized on 19.7.2017 by means of nine nozzles mounted on a supporting frame (see Fig. 4). Time duration of showering was 40 minutes. The artificial rain imitated a summer thunderstorm with exceptional but still realistic rain intensity in the climatic locality. The experiment was intentionally performed during morning time (i.e. without direct solar irradiation on the south west facade) so evaporation was relatively low. Since sprinklers were positioned more in the central part of the test fields, the narrow stripe near the perimeter of test fields stayed dry (see. Fig. 4). The total inflow of water into the sprinkler device was 1,7 litres/m²/min (68 litres/m²/40min). The value is much higher than the strongest wind driven rain observed on site during monitoring campaign. The total volume of water sucked by the test field was 13,4 litres/m²/40 min (related to wet area, outflowing and bypassed water was taken into account). Due to the limited size of the sprinkler device joist pockets located on both vertical sides of test walls were not loaded as much as joist pockets located in the central part of test walls. Based on the porosity of the plaster and bricks and the total amount of water absorbed, it can be estimated that the saturated zone was approximately located up to a depth of 5 cm when the artificial rain was finished.

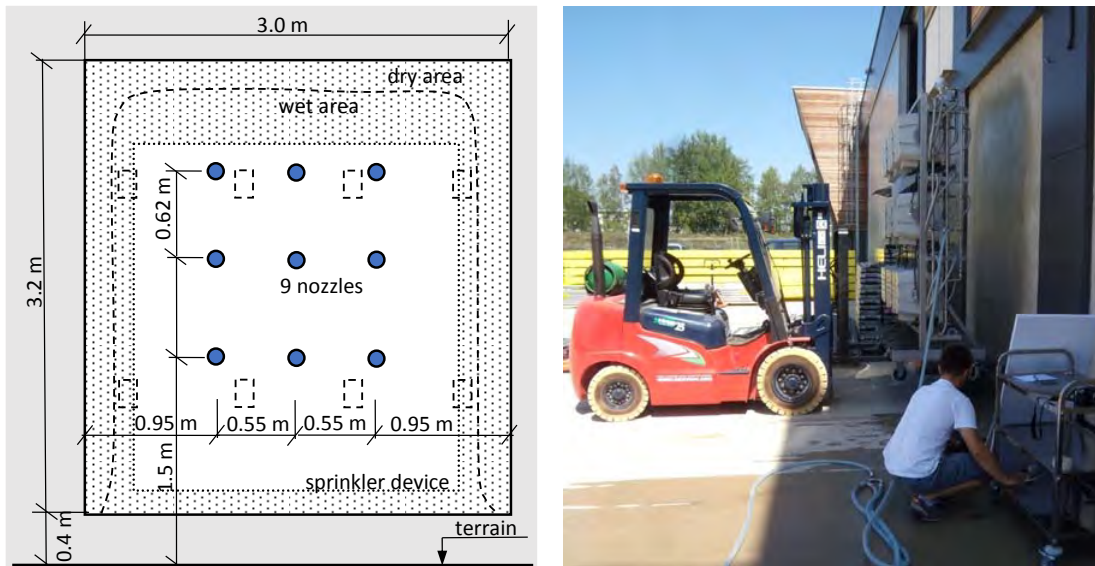

Figure 4. Left – the front view on the test field with position of sprinklers and wooden beam ends. Right – the sprinkler device positioned in the front of the test field.

RESULTS

Long-term measured data are summarized in Fig. 5.

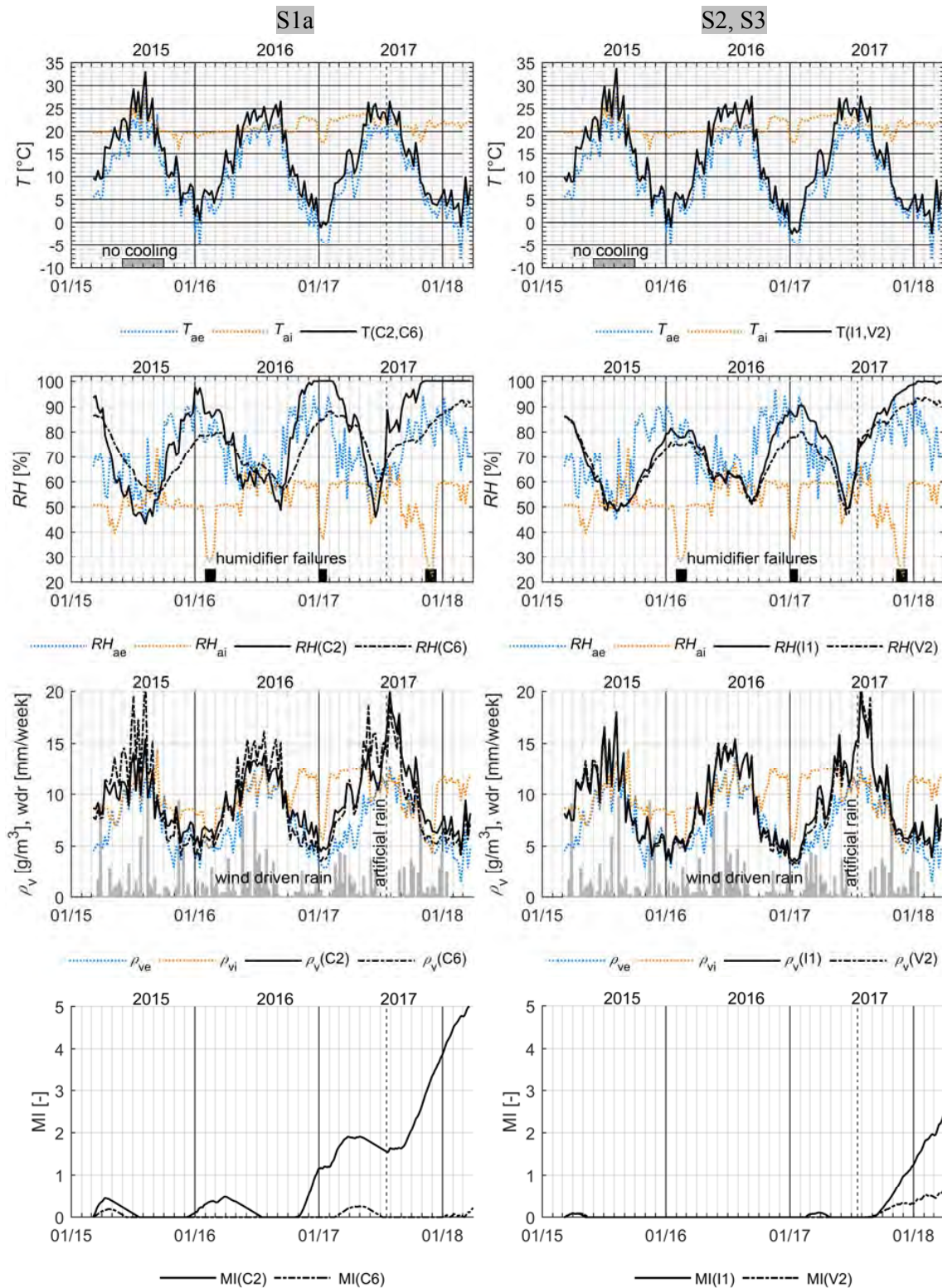

Figure 5. Measured data - temperature, relative humidity, water vapor concentration (weekly averages) and calculated mould growth index (hourly values) for selected joist pockets. Left column – system S1. Right column – systems S2 and S3. Temperature and relative humidity were measured in the bottom part of joist pockets (see Fig. 2).

Data depicted in Fig. 5 comprises weekly average values of temperature, relative humidity and water vapor concentration. Wind driven rain load was calculated by a simplified method of (Straube, 1998) for the spot near the ground in front of the test walls. Mould growth index was calculated by the improved version of VTT mold growth model (Viitanen and Ojanen 2007). The input parameters are material (spruce wood), wood surface quality (resawn) and hourly values of temperature and relative humidity measured in joist pocket.

Relative humidity in joist pockets exceeded 80 % during the experiment. Relative humidity in unsealed joist pocket (C2) of water vapor open system S1 reached 100 % in December 2016 resp. in November 2017. Relative humidity in sealed joist pocket (C6) of vapor open system S1 overshoot 90 % in February 2018. Relative humidity in the sealed pocket (I1) of vapor closed system S2 reached 100 % in January 2018. Relative humidity in the sealed pocket (V2) of vapor closed system S3 exceeded 90 %.

DISCUSSION

Similar patterns in time profiles of relative humidity in joist pockets were observed in the first two cold seasons of the experiment. There is obvious negative correlation of relative humidity in joist pocket with external air temperature. Moreover, relative humidity signals were delayed and dampened (with exception of amplitude amplification in the unsealed pocket C2) if compared with relative humidity of external air. Time lag and amplitude are related with the treatment of pockets and the type of insulation system. Relative humidity profiles during the last year of experiment differed from the patterns observed in the first two cold seasons. Relative humidity and water vapor concentration in joist pockets was increased after the rain experiment. Increase of relative humidity occurred even though mean external air temperature stayed near 20 °C for one and half month after the rain experiment. Relative humidity in joist pockets overtook relative humidity of the external air in time. Consequently, drying season was shortened. Surprisingly, only the sealed joist pocket C2 in vapor open system S1 did not show overtaking trend after the artificial rain experiment.

Water vapor concentration in joist pockets was systematically higher than water vapor concentration in the internal and external air during summer months. Both internal and external water vapor concentration were in equilibrium in summer months (no dehumidification incorporated in the air handling unit). Therefore, some other moisture sources than both ambient environments has to be responsible for that offset. Since the external surface temperature is on average higher than external air temperature during summer time and wind driven rain load tends to be higher in summer, it can be deduced that increased water vapor concentration in joist pockets is due to moisture flow from external side towards joist pockets. In addition, desorption of adsorbed moisture from wooden beam end also takes place.

Relative humidity in joist pockets was kept safe only during the first cold season of the experiment. Initial built-in moisture dried (as a consequence of very warm summer 2015). Even sealed joist pockets tended to overshoot the critical relative humidity 80 % in cold season under higher internal moisture load. Mould growth index indicated problems in unsealed joist pocket C2 in vapor open system S1 whereas mould growth was not predicted in joist pockets of vapor closed insulation systems S2 and S3 under higher internal moisture load. Even joist pockets in vapor closed systems suffered from possible mould growth after the artificial rain event (at the end of cold season 2018). It should be noted that probability of a rain event with similar intensity is low in the locality. Moreover, mould growth index is no

proof. Therefore, material samples will be taken from wooden beam ends at the end of the experiment (spring 2018). Samples will be tested in a laboratory for presence of molds. In addition, mutual comparisons of measured data in joist pockets with measured data from 1D section of insulation systems could introduce useful information.

Some unexpected results were registered after the artificial rain experiment:

- Sealed joist pocket C6 experienced slower increase of relative humidity than unsealed joist pocket C2. Due to the effect of tape on the outflow of vapor from joist pocket towards interior one would expect faster increase of vapor concentration than in unsealed joist pocket C2. Such performance might be caused by non-uniform rain load introduced by sprinkler device (i.e. joist pocket C6 did not receive the same amount of water as pocket C2).
- Sealed joist pocket V2 experienced slower increase of relative humidity than sealed joist pocket I1. This is suspect since diffusion resistance of internal layers should theoretically be much higher in case of insulation system S3. Such performance cannot be attributed with non-uniform rain load since both joist pockets are located next to each other at the same height. In this case, the slower increase of relative humidity might be related with joints between insulation plates of vacuum insulation panels (effective diffusion resistance of insulation system S3 is reduced).

The experiment will be modified in spring 2018. Some missing variants will be built (e.g. an unsealed joist pocket in uninsulated masonry either with or without metal anchor, joist pocket with non-hygroscopic beam, etc.). Moreover, sensor instrumentation so far is not sufficient to deduce directions of moisture flows. With this respect, combined temperature and relative humidity sensor should be placed at the external and internal side of test walls (close to the surfaces). Moreover, combined temperature and relative humidity sensor should be mounted at the interface of cold side of insulation layer and wooden beam.

CONCLUSIONS

The presented three-year long experimental results documented microclimatic conditions of wooden beam ends placed in joist pockets in three internal insulation systems attached to masonry walls located in semi-continental climate. The scope and nature of the data collected does not allow to state generally applicable recommendations. However, fundamental tendencies in performance and their relative significance can be evaluated. The more careful analysis of measured data and further real scale experiments are needed in future.

ACKNOWLEDGEMENT

This work has been supported by the Ministry of Education, Youth and Sports within National Sustainability Programme I (NPU), project No. LO1605 – University Centre for Energy Efficient Buildings.

REFERENCES

- Kopecký, P., Staněk, K., Bureš, M., Richter, J., Tywoniak, J., Experimental Investigations of Wooden Beam Ends in Masonry with Internal Insulation, *Energy Procedia* 132, 2017.
- Straube, J.F. Moisture Control and Enclosure Wall Systems. Ph.D. Thesis, Civil Engineering Department, University of Waterloo, Waterloo, Canada, 1998.
- Viitanen, J., Ojanen, T. Improved model to predict mold growth in building materials. In: *Proceeding of thermal performance of the exterior envelopes of whole buildings X*. American Society of Heating, Refrigerating and Air-Conditioning Engineers, 2007.