

Syracuse University

SURFACE

Architecture Senior Theses

School of Architecture Dissertations and
Theses

Spring 2010

Metamorphose

Elijah Yoon

Follow this and additional works at: https://surface.syr.edu/architecture_theses



Part of the [Architecture Commons](#)

Recommended Citation

Yoon, Elijah, "Metamorphose" (2010). *Architecture Senior Theses*. 103.
https://surface.syr.edu/architecture_theses/103

This Thesis, Senior is brought to you for free and open access by the School of Architecture Dissertations and Theses at SURFACE. It has been accepted for inclusion in Architecture Senior Theses by an authorized administrator of SURFACE. For more information, please contact surface@syr.edu.



[meta·mor·phose]

transitive verb

- 1: to change into a different physical form especially by supernatural means
- b: to change strikingly the appearance or character of : transform**
- 2: to cause (rock) to undergo metamorphism

intransitive verb

- 1: to undergo metamorphosis
- 2: to become transformed

Elijah Yoon

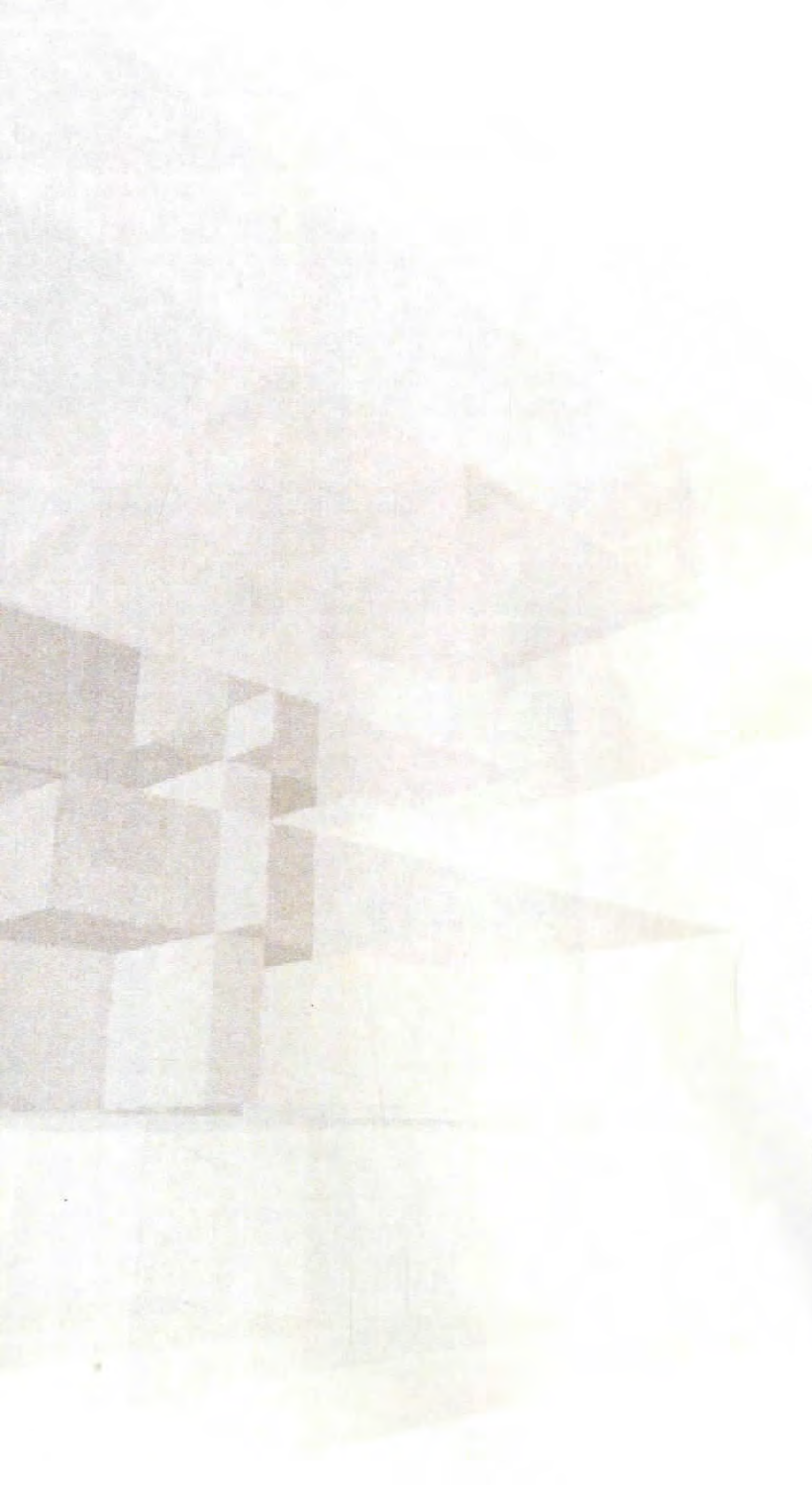

Thesis Advisors

Mark Linder
Victor Tzen

Syracuse University School of Architecture(Graduate)
ARC 998 spring 2010
Thesis



[CONTENTS]

01	Thesis Statement
02	Site Statement
04	Site History & Analysis
13	Existing Program Analysis
27	Existing Program Structure
32	Program Matrix
35	Proposed Program
40	Building Techniques
45	Program Study
48	Mapping Site Edge

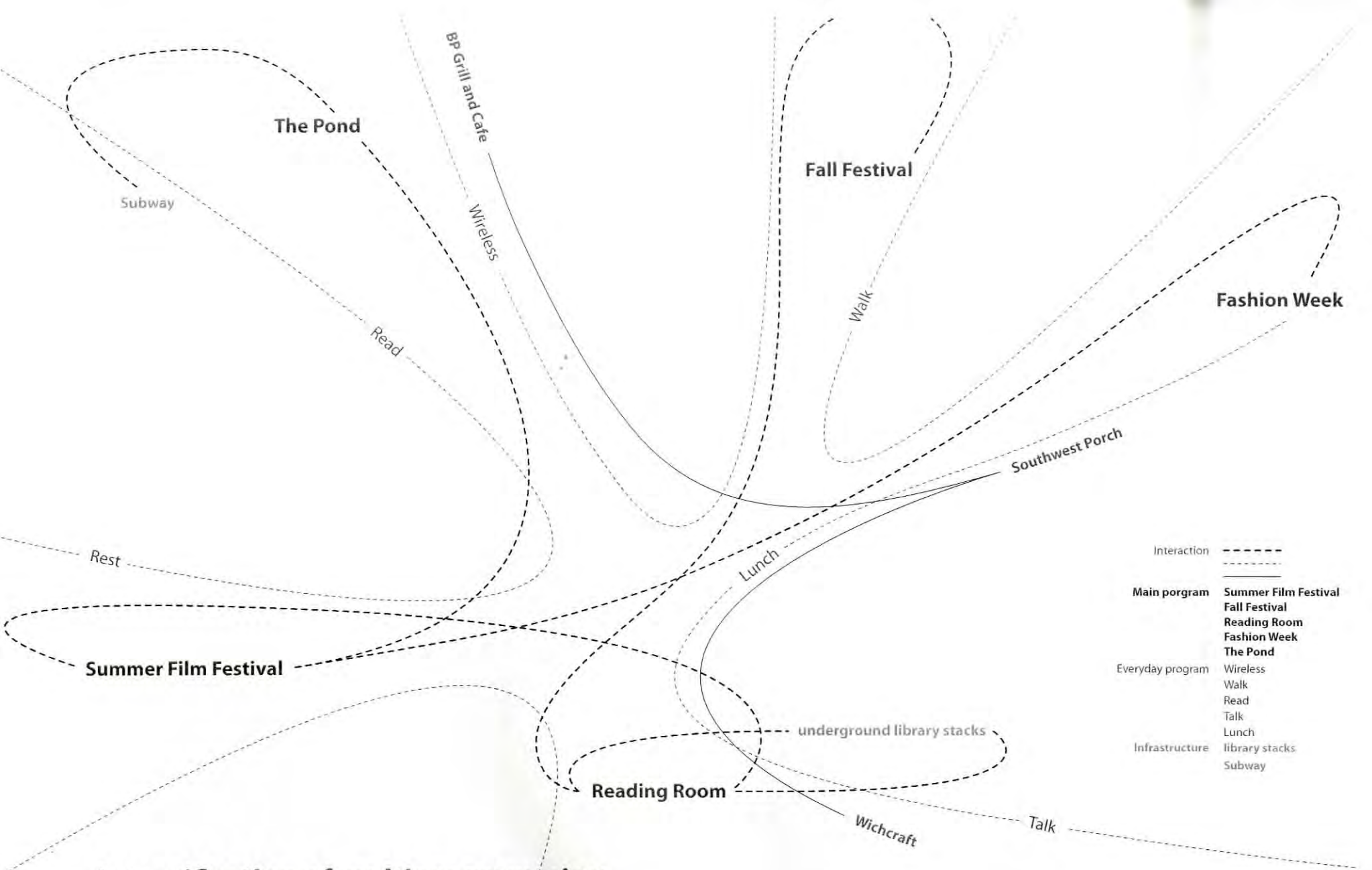

Intensification of multiprogramming

This thesis will test how Metamorphose Architecture can intensify a multi-program space as it changes over time. Metamorphose Architecture will transform as it responds to the purpose, inhabitation and structure of changing programs to allow maximum efficiency. This transformation will in turn create changes in the appearance and character of the space.

Site Statement

Bryant Park in New York City has great potential for testing out Metamorphose Architecture. During lunch hours on a sunny day, the site is frequented by 5,000 to 20,000 visitors. This pedestrian traffic is generated by the people who work in the offices surrounding the park, visitors to the New York Public Library, and tourists coming and going from Times Square, which is a block away. As a public forum, Bryant Park provides multiple events year round such as concerts, performances, fashion shows, film festivals, ice skating and product launches. Some of the programs are open to public while some are highly private. The challenges of accommodating such diverse programs in Bryant Park make it an ideal site for developing Metamorphose Architecture.

Metamorphose Architecture will enhance programs that exist in Bryant Park. At the moment, the only permanent structures are the restaurant and kiosk. Temporary structures have to be set up to accommodate other programs. For Bryant Park to meet its potential and develop as a public space, there needs to be a permanent yet flexible structure. This structure must be able to transform according to program as well as being able to house multi-programs simultaneously. Moreover Metamorphose Architecture proposes to solve the most pressing problem facing Bryant Park which is the loss of public space due to private functions such as Fashion Week. Fashion Week is one of the largest events at Bryant Park and also one of the most private. Its existence disrupts the public use of the park by closing off 90% of the main lawn from the public. Metamorphose Architecture will create a permanent space that can house such events without disrupting public access and use of the park.

Metamorphose Architecture will create the flexibility required to maintain a balance between public and private program. The flexibility of the structure itself will allow for maximum efficiency of program.

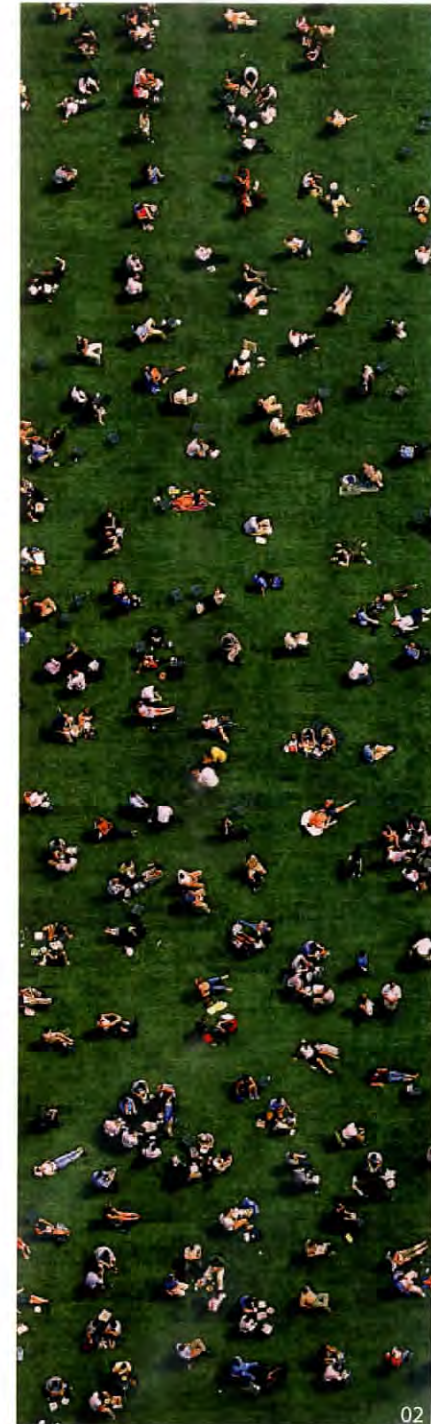



Bryant Park History

- 1686** New York's colonial governor Thomas Dongan designated as public property the land that is now Bryant Park.
- 1847** following the construction of one of the city's most imposing edifices, the Croton Distributing Reservoir, on the present site of the New York Public Library, the city designated the former potter's field to its west as a public park called Reservoir Square, a simple Victorian greensward.
- 1850** New York had grown to sufficient size and prominence that the city decided to host a major exhibition of the type that London had recently pioneered. Such early exhibitions were forerunners of the later world's fairs. The "Exhibition of the Industry of All Nations" opened on July 14, 1853, in a sparsely developed part of the city. Fortieth and Forty-second streets bounded the fair's four-acre site to the immediate west of the Croton Distributing Reservoir—today's Bryant Park.
- 1853** New York's first "world's fair," the Crystal Palace Exhibition, took place on the site of Bryant Park. The exhibition set off one of the first major tourism booms in New York, and many hotels were built to handle the influx of visitors. Over one million people visited the Crystal Palace Exhibition, which closed on November 1, 1854. The remarkable iron and glass structure erected to house the fair remained standing until 1858, when it burned down.
- 1884** Reservoir Square was renamed Bryant Park, to honor the recently deceased poet and editor William Cullen Bryant. Bryant (1794-1878) was a poet, newspaper editor, and civic reformer.
- 1878** The Sixth Avenue Elevated Railway was constructed.
- 1992** New York City's powerful parks commissioner, the legendary public-works "czar" Robert Moses, undertook to rescue and redesign the park during the Great Depression. Queens-based architect Lusby Simpson won a competition for the park's redesign, a classical scheme of a large central lawn, formal pathways, stone balustrades, and borders of London plane trees, together with an oval plaza, containing the Lowell Fountain, at the west end, separated from Sixth Avenue by a broad flight of steps. Moses's staff, including the architect Aymar Embury II and the landscape architect Gilmore D. Clarke, oversaw execution of Simpson's plan.

- 1980** The Rockefeller Brothers created the Bryant Park Restoration Corporation (BPRC), under the founding leadership of Andrew Heiskell, then Chairman of Time Inc. Harvard Business School graduate and systems consultant with a reputation as an innovator in downtown management. Heiskell and Biederman, in 1980, created a master plan for turning around the park. In the words of an Urban Land Institute case study, "Biederman began experimenting with a series of efforts to bring people back to the park, while also exploring how to generate revenue." A seven-year push combined supplementary park maintenance, temporary kiosks, and public events ranging from historical park tours to concerts, which reduced crime by 92 percent and doubled the number of annual park visitors.
- 1988** Summer 1988 saw city agencies approve BPRC's plans (drafted by Hanna/Olin Ltd.) to build new entrances for increased visibility from the street, to enhance the formal French garden design (with a lush redesign by Lynden Miller), and improve and repair paths and lighting. BPRC's plan also included restoration of the park's monuments, and renovation of its long-closed restrooms. That same summer, the city approved BPRC's designs (by Hardy Holzman Pfeiffer Associates), for two restaurant pavilions and four concession kiosks, which were to generate off-peak activity and added revenue for operations. These facilities opened in stages in the 1990s.
- 1992** Bryant Park reopened in April, 1992, to lavish praise from citizens and visitors, the media, and urbanists. And, as the Urban Land Institute wrote it in an award citation, "the success of the park feeds the success of the neighborhood." Soon the chorus was joined by the business community, whose assessments helped fund the renewal and now benefit from higher rents and property values.



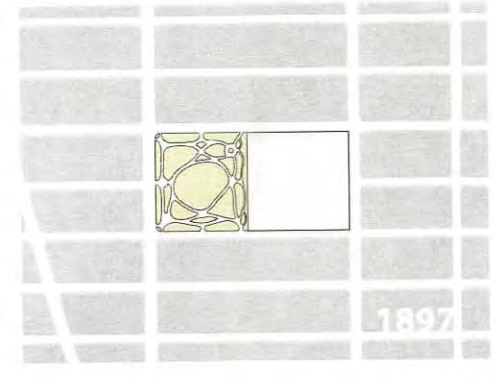
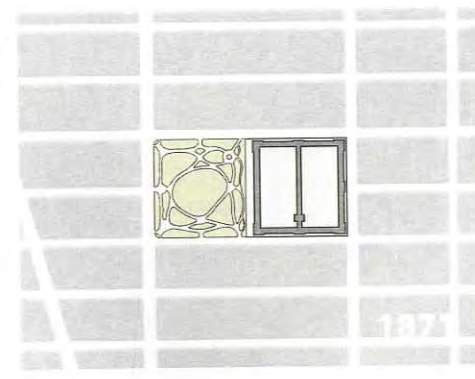
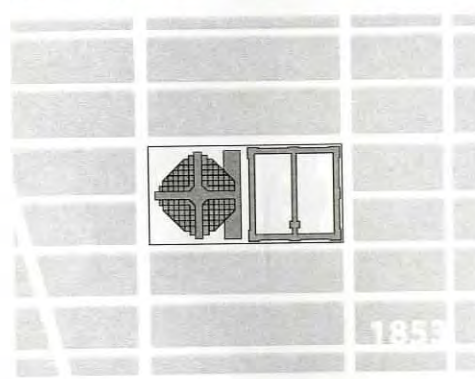
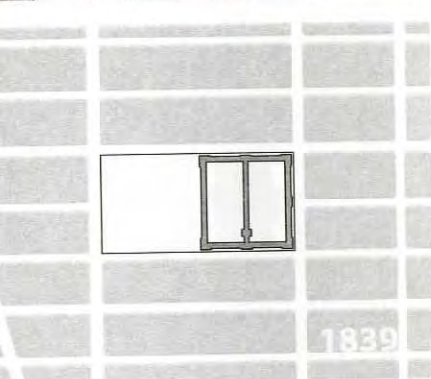

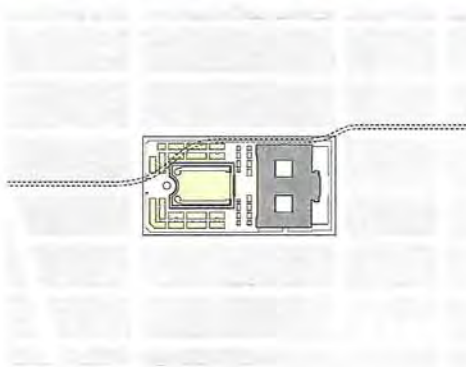
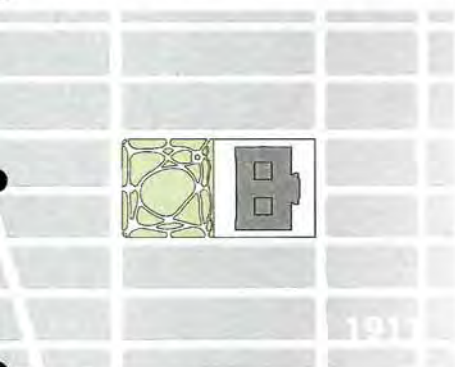

New Infrastructure
Subway Station(Queensboro subway)

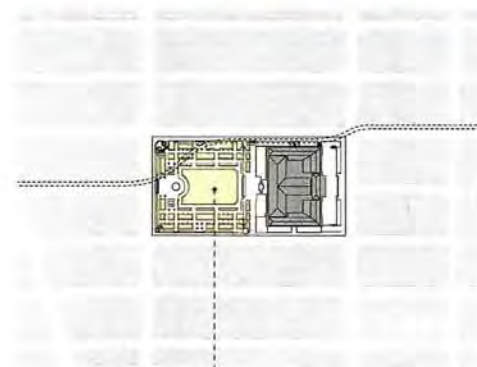

Underground Library Stacks



When this photo of the intersection of Sixth Ave. and 42d St. was taken in 1918, Bryant Park was used for the planting of WW I Victory Gardens, a patriotic activity to ease a scarcity of vegetables during the war. Bush Tower, the 30-story office building at left, loomed above the skyline, and the El ran along Sixth Ave.

New York's Changing Scene

N.Y. Sunday News Apr. 16, 1922



In 1932, as part of the George Washington bicentennial celebration, a replica of Federal Hall was erected in Bryant Park, behind the N. Y. Public Library. The original Federal Hall was at the corner of Wall and Nassau Sts. Looking east from Sixth Ave., at left is Salmon Tower on W. 42d St., and next to it the 500 Fifth Ave. Building.

New York's Changing Scene



Today, Bush Tower is matched in size by many buildings and dwarfed by others. The El was razed in 1938, and Sixth Ave., later renamed Ave. of the Americas, soon took on a taller look. Now enhanced with trees, fountains, and statues, Bryant Park is often the site of free concerts and art exhibits of large outdoor sculpture.



Today, Bryant Park is a lunch-time gathering place for office workers, the scene of rallies, flower shows, summer concerts and a dozen other all-season activities. A few new buildings have gone up in the area since the earlier photo, but the skyline is relatively unchanged. Soire at left center is stoop Chrysler Building.

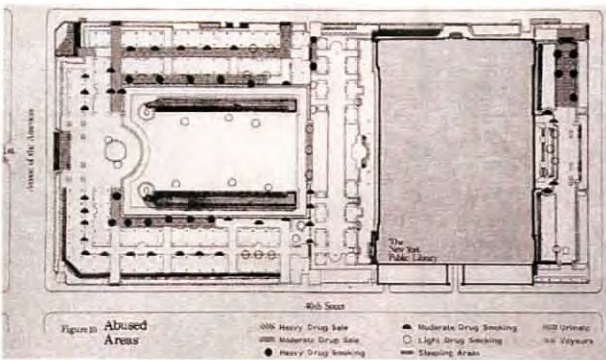

Distribution of criminal and antisocial activities in park as documented by William H. Whyte, 1980

1969

1972

1980



Thursday night is singles night in Bryant Park, the midtown park that has become a hot spot after a major renovation changed it from a gathering spot for drug dealers to a place to see and be seen for nearby office workers and others.

Town Square Of Midtown

Drug Dealers' Turf Is Now an Office Oasis

By BRUCE WEBER

The young professionals were packed in at the outdoor terrace bar at the Bryant Park Cafe, four, five, six deep, hundreds of 20- and 30-something men with their jackets off and ties loosened, women in linen suits or sleeveless dresses. The temperature was in the 90's, but the socializing was full throttle.

"It's always a madhouse on Thursday," said Nelson Mercado, a park security officer on restaurant detail, standing outside the bar's restraining ropes.

Inside the after-work, anxious-for-the-weekend crowd flirted, drank beers and pastel-colored cocktails out of plastic cups and sang the praises of a place to go in the open air to relax after office hours and perhaps begin an evening of social adventure.

"Do I not go out every Thursday night, and do I not look for the hot spot?" Robert Zeidman, a computer software salesman, asked rhetorically. "China Grill was the hot spot in the spring. Now this is the place."

Bryant Park? Hot?

It would be a hard point to argue, given the crowd and its exuberance, though a few scant years ago it would have been the most unlikely of gathering places. The Thursday-night scene at the Bryant Park Cafe (an offshoot of the more formal Bryant Park Grill just south) has accrued its popularity quickly since it opened in May. But it is only the latest exclamation point for the overwhelmingly active scene at Bryant Park, the renovated nine-acre rectangle between 40th and 42d

Continued on Page B2

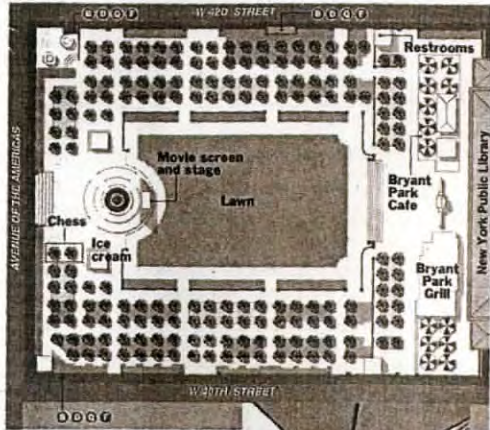

ABOVE Chess attracts Rudi Mathers to the section of Bryant Park reserved for chess and backgammon.

RIGHT From the roof of the Bryant Park Grill, the park looks like the front yard of midtown Manhattan.



THE WALL STREET JOURNAL

1/23/95

FUTURES & OPTIONS / By Robert J. Hughes

Screen Stars, Under the Stars



New York's Bryant Park will become an open-air movie theater on Monday nights through Aug. 25.

Existing Condition



- NYC Parks
- Multi-family Residential
- Mixed Use
- Commercial
- Institutions
- Transportation
- Industrial
- Vacant Lots

Supporting Program(private/semi public)

Summer Film Festival

Fall Festival

10 after-work performances featuring artists from NYC's great dance, musical theater, opera, jazz, and classical music institutions.

The Pond

The Pond is the centerpiece of Bryant Park's winter season, which also includes the annual Holiday Shops at Bryant Park. The 170' x 100' rink features free admission ice skating, in addition to high quality rental skates, skating shows, special events, and activities. Whether you are looking to skate before going to the office, through the lunch hour, with friends at a party, with a date, or for a spin under the stars at a holiday party, The Pond at Bryant Park, made possible by Citi, is the perfect destination.

Piano in the Park

Some of the best pianists from all over New York come to Bryant Park to play on the Piano in the Park. Tap your toes to the music of Scott Joplin, the Gershwins, James P. Johnson, Fats Waller, Eubie Blake, Jelly Roll Morton, and more every weekday. The custom-made piano and series has been created by Bryant Park in partnership with Local 802 of the American Federation of Musicians, the Music Performance Fund, and Sam Ash Music Stores.

Yoga & Tai ChClasses

Meet the Birds

Reading Room

The original Reading Room began in August of 1935 as a public response to the Depression Era job losses in New York. Many people did not have anywhere to go during the day, and no prospects for jobs. The New York Public Library opened the "Open Air Library" to give these out-of-work businessmen and intellectuals a place to go where they did not need money, a valid address, a library card, or any identification to enjoy the reading materials.

The Bryant Park Corporation has repeated history by recreating the Bryant Park Reading Room. It is modeled after the original with the additions of custom-designed carts for an extensive and eclectic selection of books, periodicals and newspapers; readings and programs at lunchtime, after work and for kids; movable furniture to create a more intimate environment; and kid-sized carts and furniture for children to use.



Fashion Week



Summer Film Festival



The Pond



Yoga & Tai ChClasses



Reading Room

Everyday Program (Public)

Lunch

Walk

Read

Talk

Play

Rest

Wireless



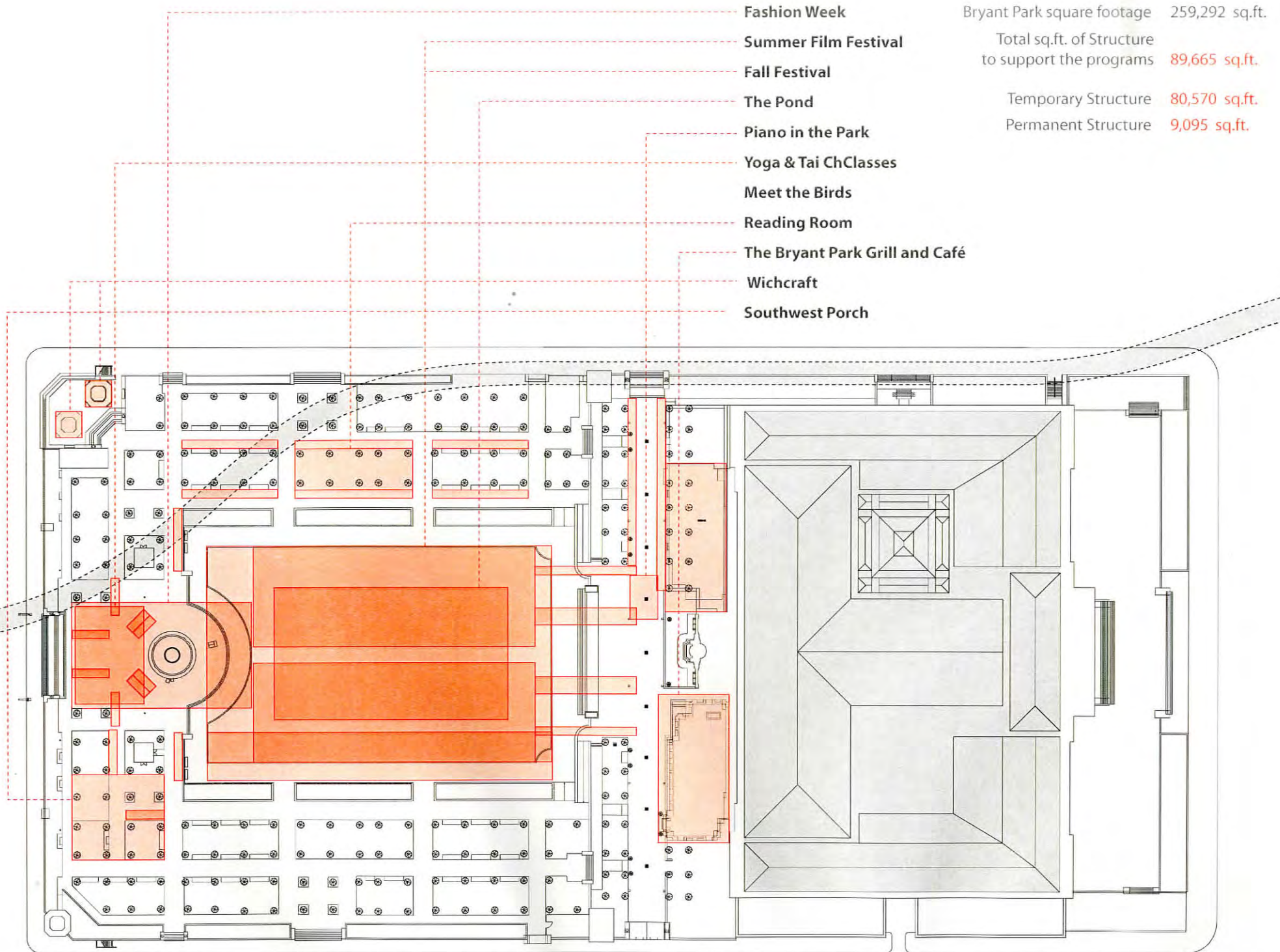

- Fashion Week
- Summer Film Festival
- Fall Festival
- The Pond
- Piano in the Park
- Yoga & Tai Chi Classes
- Meet the Birds
- Reading Room
- The Bryant Park Grill and Café
- Wichcraft
- Southwest Porch

Bryant Park square footage	259,292 sq.ft.
Total sq.ft. of Structure to support the programs	89,665 sq.ft.
Temporary Structure	80,570 sq.ft.
Permanent Structure	9,095 sq.ft.

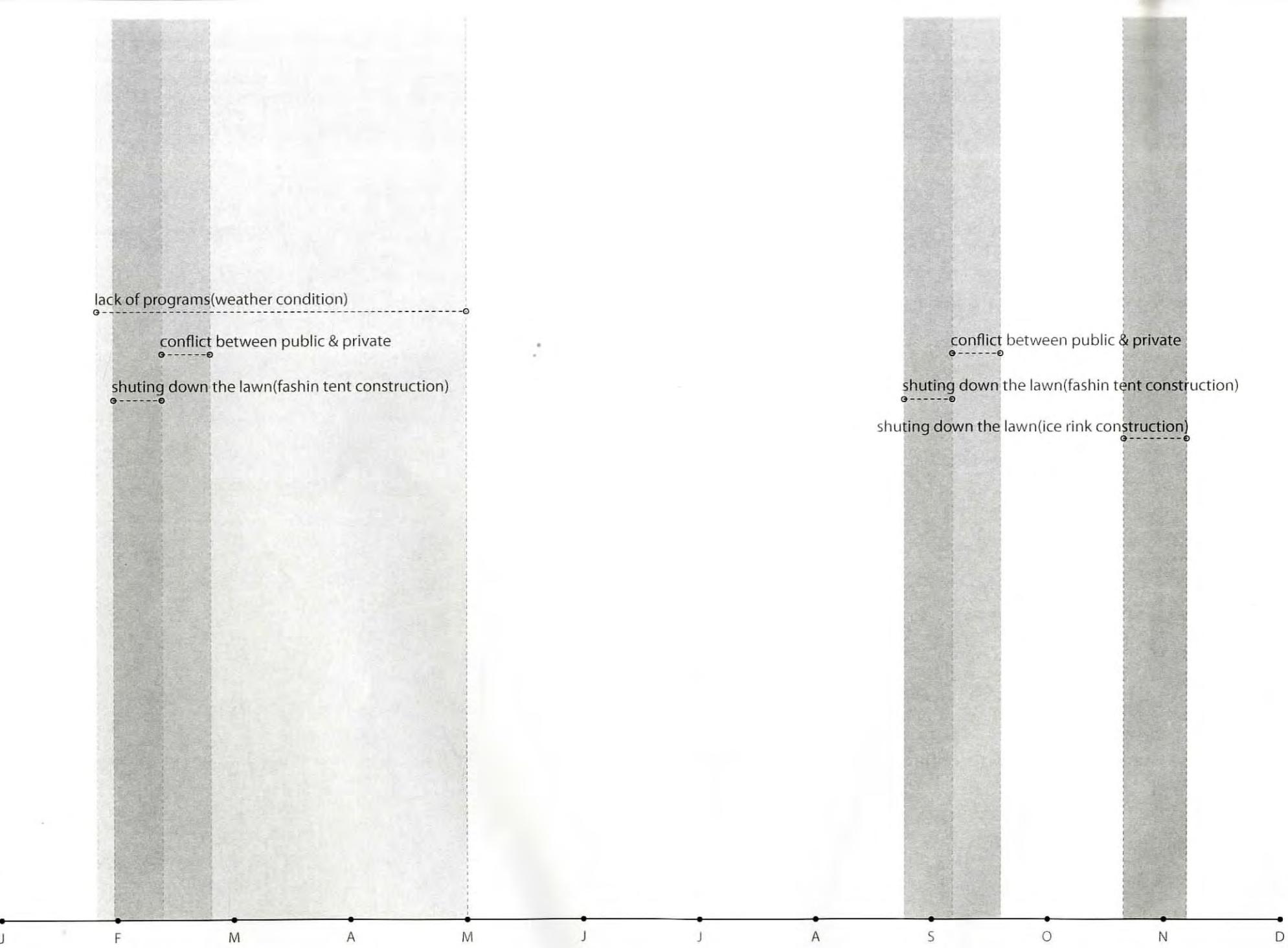

lack of programs(weather condition)

conflict between public & private

shuting down the lawn(fashin tent construction)

conflict between public & private

shuting down the lawn(fashin tent construction)

shuting down the lawn(ice rink construction)

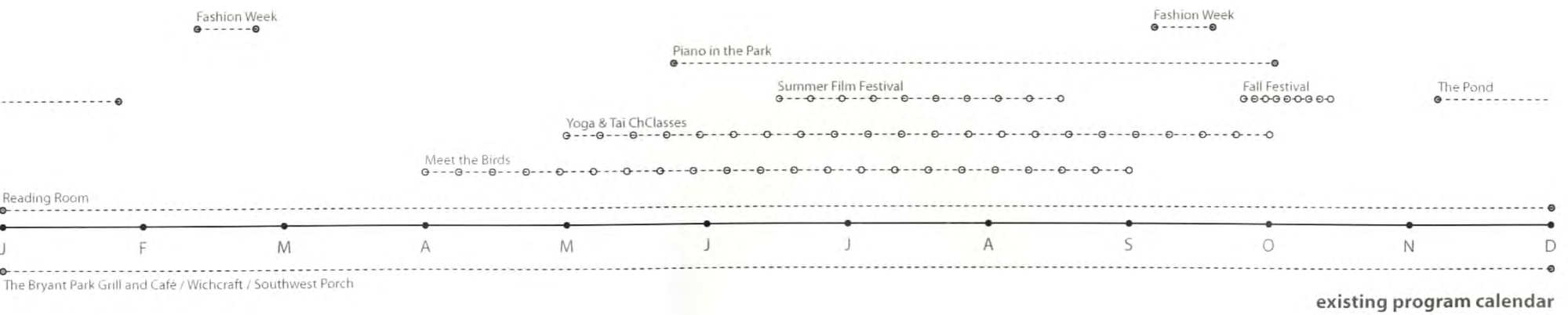

existing program calendar

Mercedes-Benz FashionWeek

American Express

Chambord

Clear

Lu Biscuits

Maybelline

Rowenta

Rouge Tomate

Sharpie



an IMG Company

ENTERTAINMENT

From fashion and lifestyle events to comedy programs and famous personalities, IMG entertains worldwide audiences on-air, online, in print and in person. As the leading international modeling agency and pre-eminent producer of Fashion Week events around the world, IMG is a dominant force in fashion. We integrate the business and fun of fashion through our fashion publications and live digital media coverage of the industry's top shows. In broadcasting, we produce award-winning entertainment programming in nearly every genre and represent accomplished on-air personalities.

The first Fall Fashion Week, held in 1993.

By September 1999, the frivolity and glamour was in full swing under the tents. With high retail sales and a booming economy, things looked promising. But midway through the week, Hurricane Floyd descended on the city, forcing the tents into lockdown

By 2003, designers were eager to create inspirational looks and strong collections to reaffirm America's strength and resilience after surviving such a catastrophic time.

By 2007, fashion was back and louder than ever. Heatherette caused a stir with their Wizard of Oz-themed show when they sent stars down the glittery catwalk.

In the last few years, the tents at Bryant Park took on a larger-than-life appeal, with the front stairs full of the kind of posing and preening more common to red carpets at awards shows. As the media fanfare heightened and Vogue editor Anna Wintour refused to take off her furs in the front row, PETA found their way to the tents in protest. In 2008, they set their sights on Donna Karan, dubbing the designer a "Bunny Butcher".

The twice-annual event, which is estimated to draw more than 100,000 visiting store buyers and fashion editors, has been under increasing pressure to find a new home after complaints from the park management that the invitation-only shows had grown too large and were restricting public access to the park.

The dispute intensified in 2006, when the Bryant Park Corporation announced it would no longer allow the shows to happen in the park, because they were interfering with plans to operate a skating rink in the winter and public use of the main lawn in the late summer. Mayor Michael R. Bloomberg was then asked by designers, as well as Anna Wintour, the editor of Vogue, to intercede on their behalf, leading to an arrangement for Fashion Week to remain there, at least temporarily.

About 63 designers are expected to present their fall 2009 collections in the park starting on Feb. 13, although hundreds of other shows are scheduled at galleries and event spaces around Manhattan. The event generates \$466 million in visitor spending each year, according to the New York City Economic Development Corporation.



THU, SEPT 10	FRI, SEPT 11	SAT, SEPT 12	SUN, SEPT 13	MON, SEPT 14	TUE, SEPT 15	WED, SEPT 16	THU, SEPT 17
9 MICHAEL ANGEL	9 CYNTHIA STEFFE					9 TORY BURCH	9 RALPH LAUREN Skylight Studio 275 Hudson St
10 BCBGMAXAZRIA		10 LACOSTE	10 LELA ROSE	10 CAROLINA HERRERA	10 BADGLEY MISCHKA	10 MICHAEL KORS	10 RALPH LAUREN Skylight Studio 275 Hudson St
11 DAVIDELFIN	11 YIGAL AZROUËL	11 GEORGES CHAKRA	11 DEREK LAM	11 CARLOS MIELE	11 BRIAN REYES	11 NANETTE LEPORE	11 RALPH LAUREN Skylight Studio 275 Hudson St
	12 TWINKLE by WENLAN		12 TONI MATICEVSKI Altman Bldg 135 W 18th St	12 JILL STUART New York Public Library			
1 DUCKIE BROWN		1 ANDY & DEBB	1 DKNY 711 Greenwich St	1 TRACY REESE	1 PAMELLA ROLAND		1 ALLUDE
2 MARA HOFFMAN NICHOLAS K WHITNEY EVE	2 CHARLOTTE RONSON	2 ADAM 450 W 15th St	2 THUY	2 DONNA KARAN NEW YORK 711 Greenwich St	2 MAX AZRIA	2 3.1 PHILLIP LIM	2 ISAAC MIZRAHI
	3 MONARCHY COLLECTION	3 ACADEMY OF ART UNIVERSITY	3 HERVÉ LÉGER by MAX AZRIA		3 DENNIS BASSO	3 MILLY by MICHELLE SMITH	3 TRIAS
3 PORTS 1961	4 LEIFSDOTTIR 209 W 38th St 7th Floor	4 CHRISTIAN SIRIANO	4 DIANE VON FURSTENBERG	4 YEOHLEE 225 W 35th St 16th Floor			4 CALVIN KLEIN COLLECTION 205 W 39th St Ground Floor
5 ROSA CHÁ			5 REBECCA TAYLOR	5 TADASHI SHOJI		5 ALEXANDRE HERCHCOVITCH	5 CALVIN KLEIN COLLECTION 205 W 39th St Ground Floor
6 FASHION'S NIGHT OUT	6 NICOLE MILLER		5 Y-3 Park Avenue Armory 643 Park Ave	6 TONYCOHEN	6 WILLOW	6 ANNA SUI	6 CHOCHENG
7 CESAR GALINDO M2 Ultra Lounge 530 W 28th St	7 ARISE:AFRICAN PROMISE COLLECTIVE	7 CHADO RALPH RUCCI	7 TULEH	7 GOTTEX	7 TIBI	6 MARIA PINTO Banchet 74 Gansevoort St	7 ARGENTINE DESIGNER COLLECTIONS
	8 ERIN WASSON x RVCA	8 VIVIENNE TAM	8 CUSTO BARCELONA		8 NARCISO RODRIGUEZ	7 DOO.RI	8 TOMMY HILFIGER
	9 VENEXIANA		9 VASSILIOS KOSTETSOS		9 TONI FRANCESC		

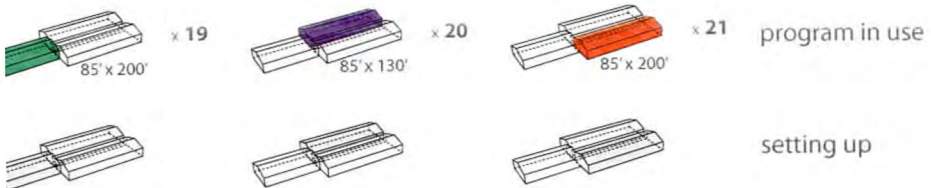

THU, SEPT 10

FRI, SEPT 11

SAT, SEPT 12

SUN, SEPT 13

MON, SEPT 14

TUE, SEPT 15

WED, SEPT 16

THU, SEPT 17

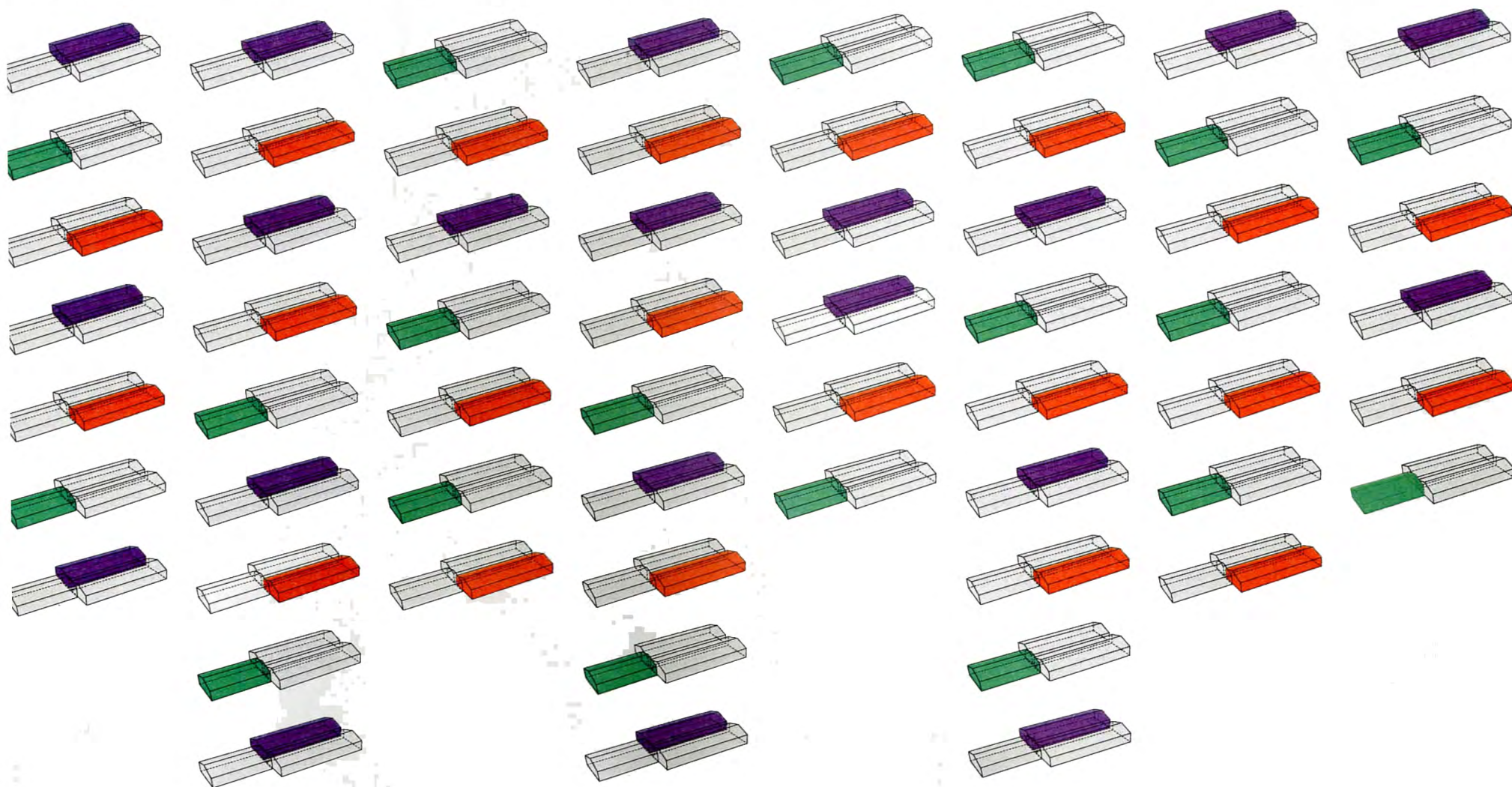

The Pond (2005)

Bryant Park, scheduled to open on Oct. 28, will be a portable, Olympic-size rink large enough for 500 skaters to pirouette upon (or slip and fall) among the high-rises of Midtown Manhattan. A rarity among the handful of ice rinks in Manhattan, it will have no admission charge, and organizers hope it will attract crowds during the winter when the park is nearly empty. "It's freezing out there from Nov. 1 to March 31 and sometimes later - and so for five months we do nothing," said Daniel A. Biederman, executive director of the Bryant Park Restoration Corporation. "So we said, 'Let's make Bryant Park usable in the winter.'"

The Bryant Park rink, which will take two weeks to put in place and cost \$4 million, will measure 17,000 square feet about half the size of Wollman and about twice the size of the Rockefeller Center rink. The temporary rink will be put directly onto Bryant Park's sod, necessitating that the lawn's crown - built to keep rain and snow melt from pooling - be flattened first. The rink's three-inch surface of ice will be laid atop layers of plastic and foam.

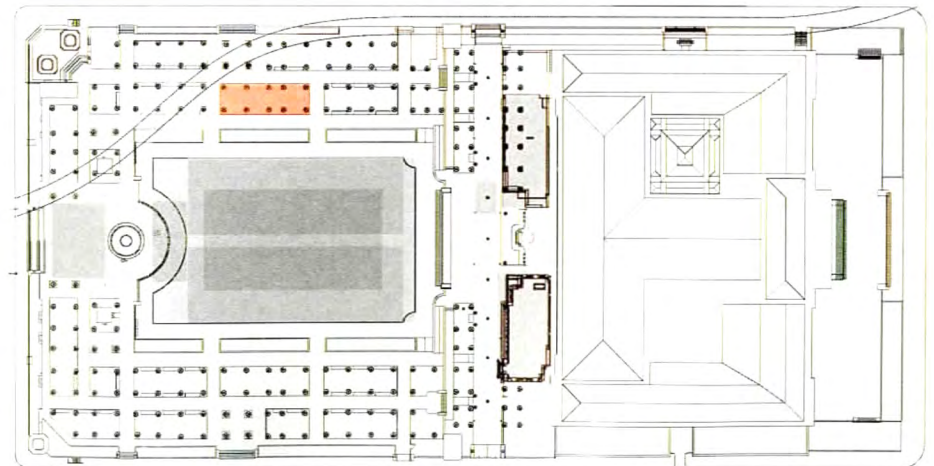
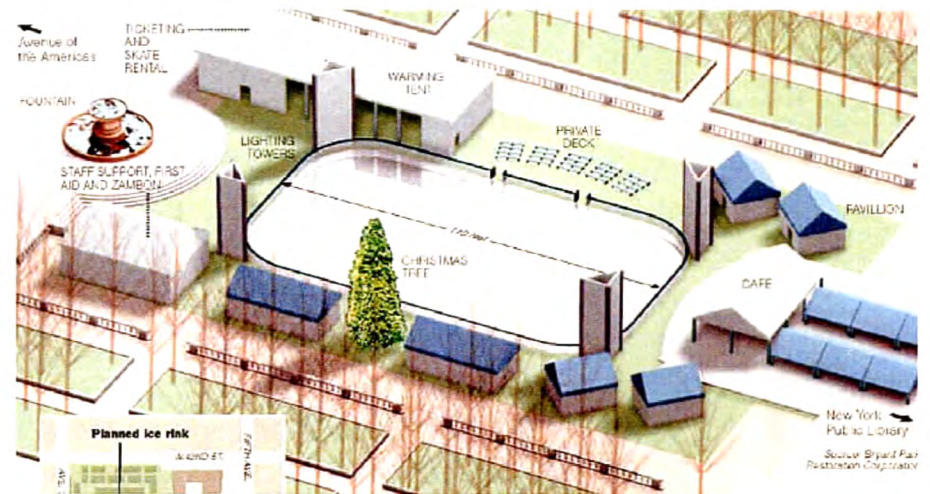

Reading Room (2002)

The original Reading Room began in August of 1935 as a public response to the Depression Era job losses in New York. Many people did not have anywhere to go during the day, and no prospects for jobs. The New York Public Library opened the "Open Air Library" to give these out-of-work businessmen and intellectuals a place to go where they did not need money, a valid address, a library card, or any identification to enjoy the reading materials.

The Bryant Park Corporation has repeated history by recreating the Bryant Park Reading Room. It is modeled after the original with the additions of custom-designed carts for an extensive and eclectic selection of books, periodicals and newspapers; readings and programs at lunchtime, after work and for kids; movable furniture to create a more intimate environment; and kid-sized carts and furniture for children to use.

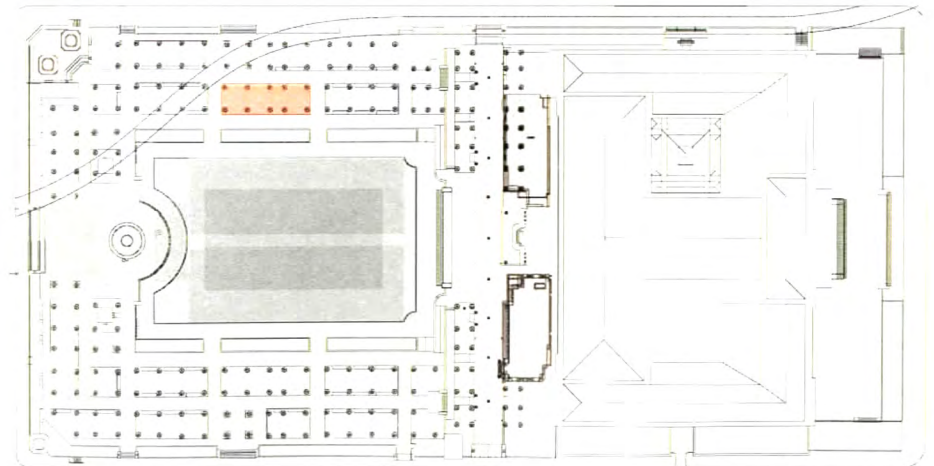

connection between the READING ROOM & the underground LIBRARY STACKS?
direct access from the SUBWAY(infrastructure) to the BRYANT PARK?
providing a PERMANENT STRUCTURE?

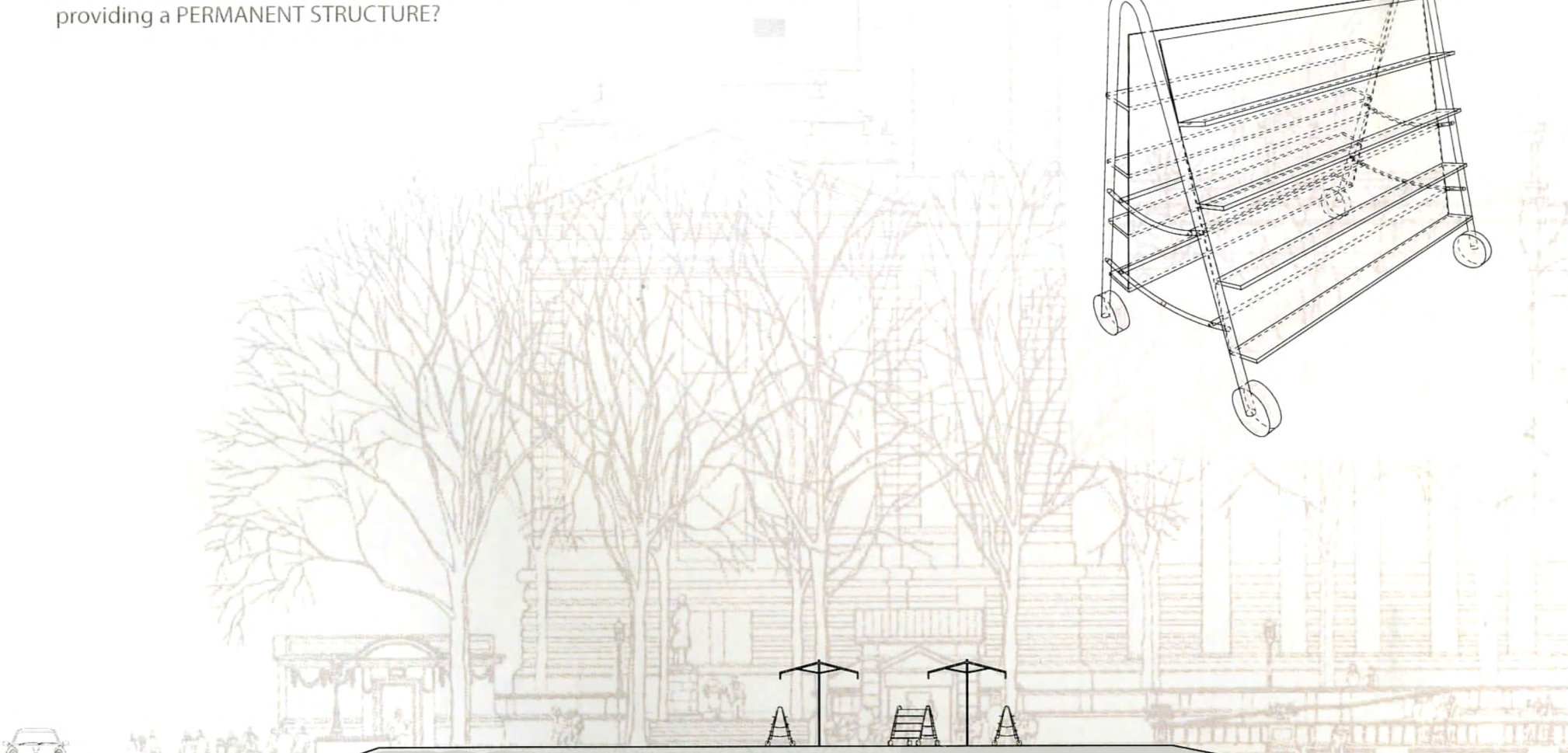

UNDERGROUND
LIBRARY STACKS



QUEENSBORO SUBWAY

Bryant Park square footage	259,292 sq.ft.
Fashion Week	64,945 sq.ft.
Fall Festival	800 sq.ft.
Summer Film Festival	400 sq.ft.
The Pond	28,183 sq.ft.
Shops(winter)	15,625 sq.ft.
Yoga & Tai Chi Classes	5,762 sq.ft.
Reading Room	3,135 sq.ft.
Wichcraft	625 sq.ft.
Southwest Porch	2,100 sq.ft.
The Bryant Park Grill and Café	6,370 sq.ft.

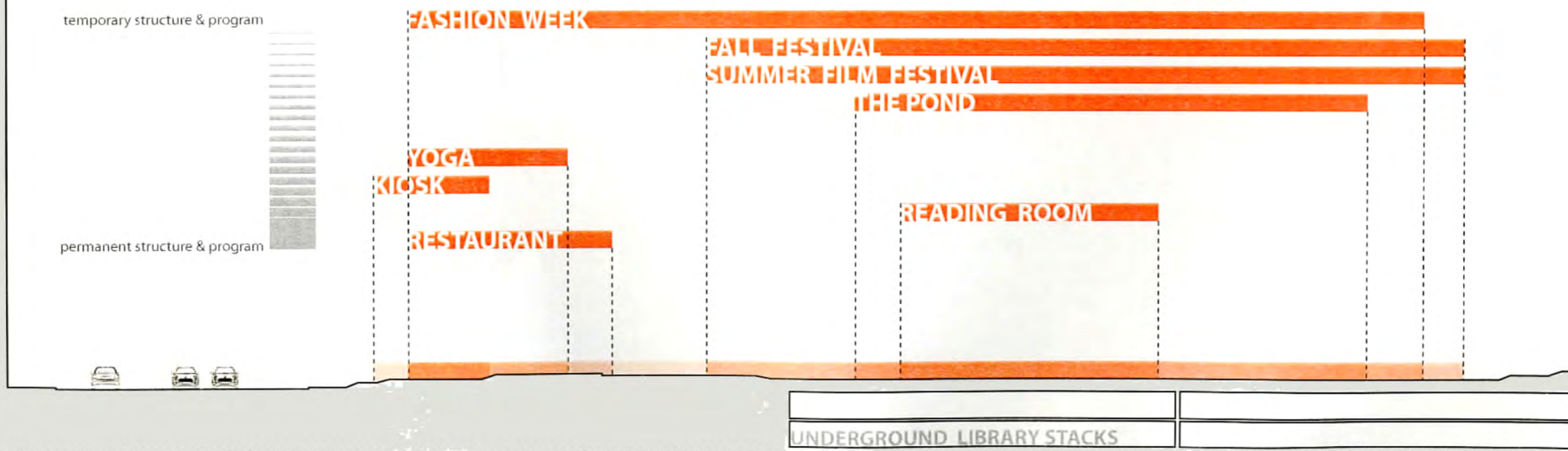

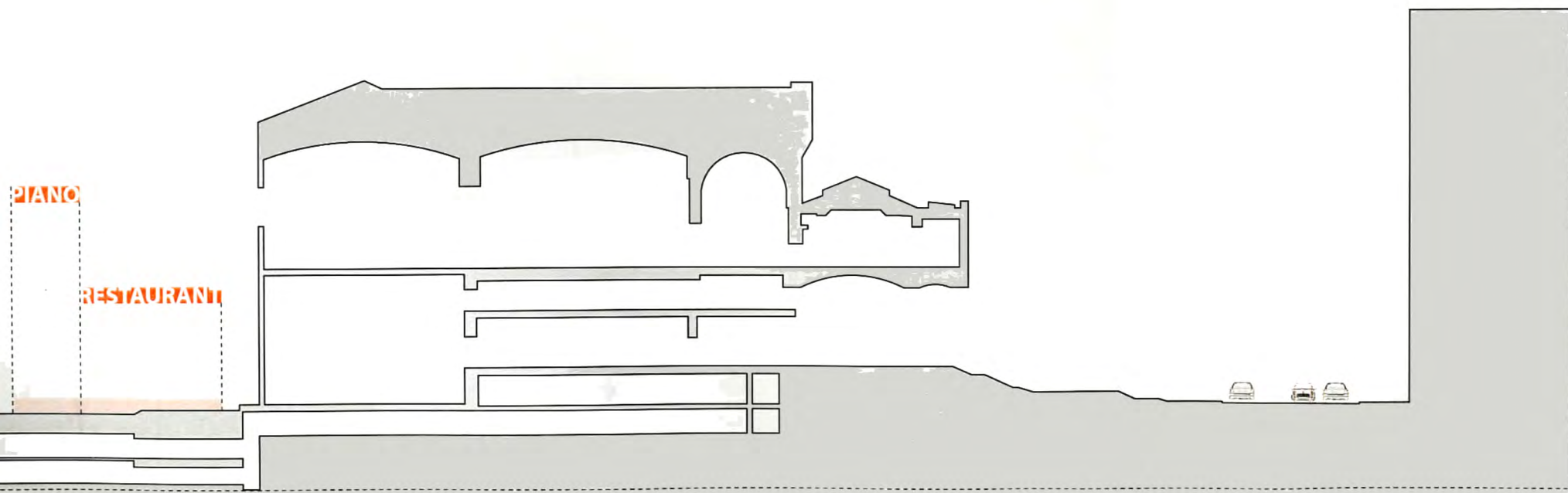

PIANO

RESTAURANTI

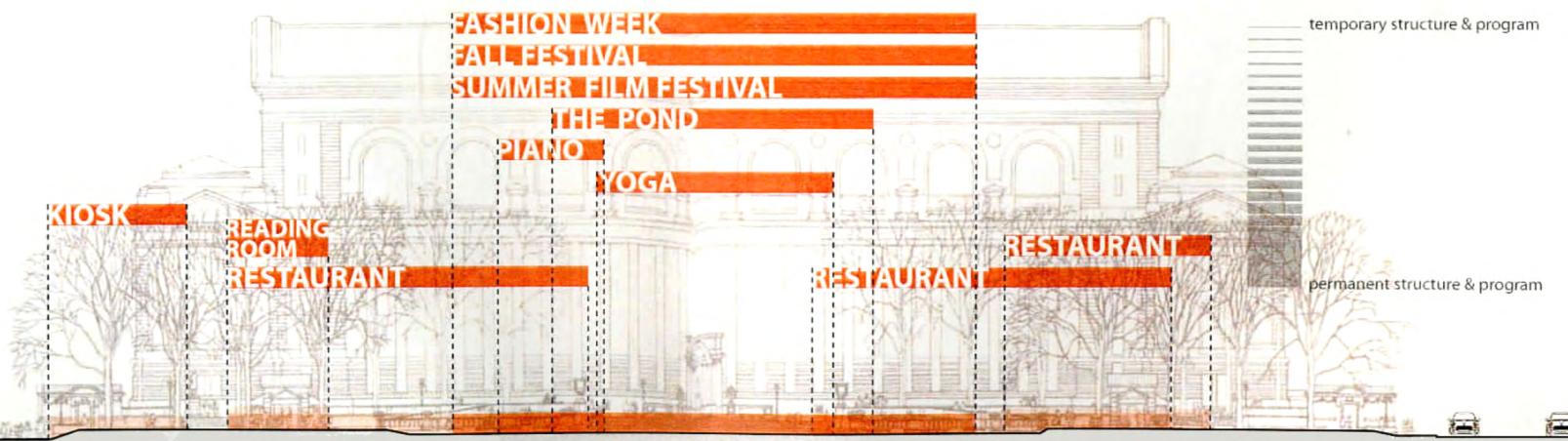

FASHION WEEK

FALL FESTIVAL

SUMMER FILM FESTIVAL

THE POND

PIANO

YOGA

KIOSK

READING ROOM

RESTAURANT

RESTAURANT

RESTAURANT

temporary structure & program

permanent structure & program



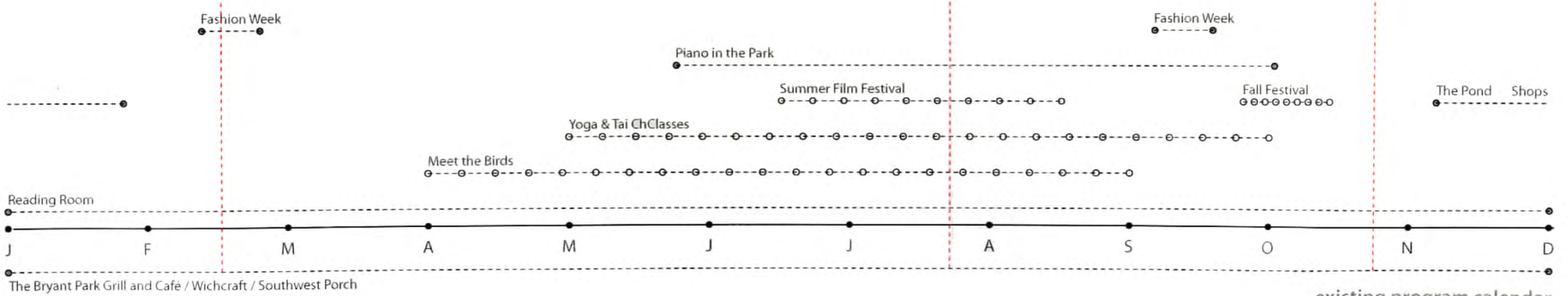
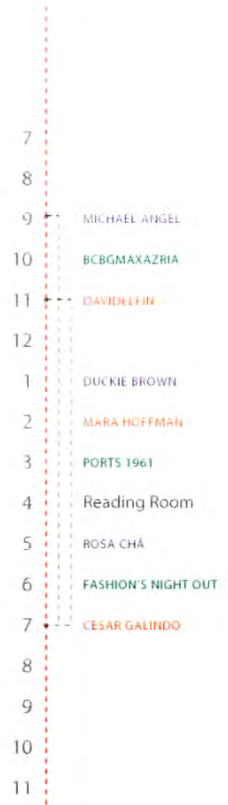

UNDERGROUND LIBRARY STACKS

QUEENSBORO SUBWAY



The Bryant Park Grill and Cafe / Wichcraft / Southwest Porch

existing program calendar

-  everyday program
-  public inhabitants
-  private inhabitants
-  temporary structure



7

8

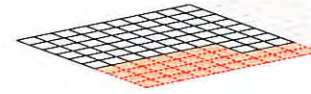

9

MICHAEL ANGEL

10

BCBGMAXAZRIA

11

DAVIDELFIN

12

1

DUCKIE BROWN

2

MARA HOFFMAN

3

PORTS 1961

4

ROSA CHÁ

5

FASHION'S NIGHT OUT

6

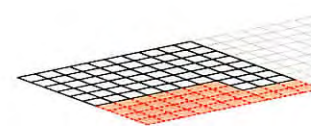

7

CESAR GALINDO

8

9

10





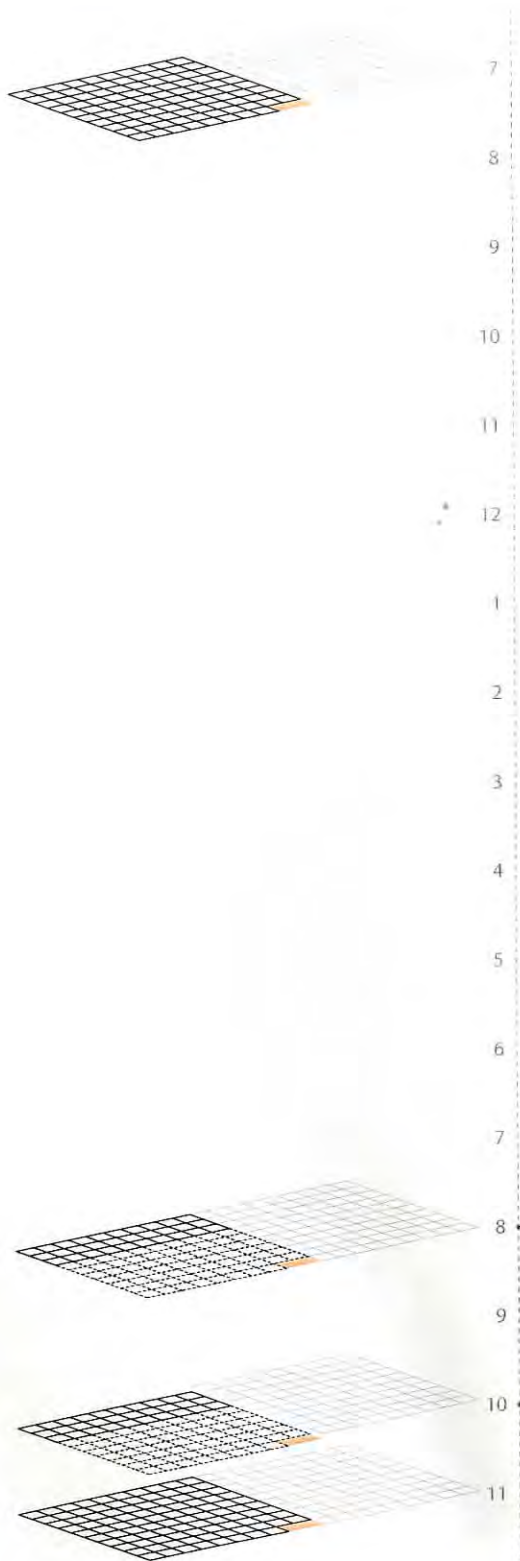

11

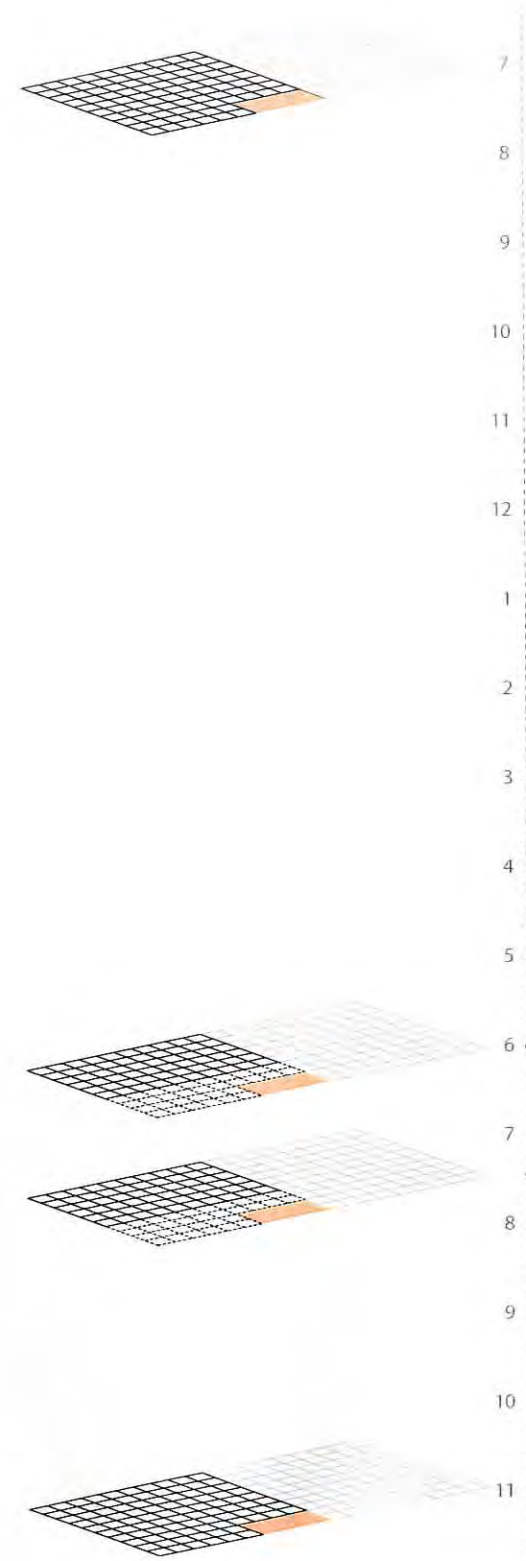

Summer Film Festival



Fall Festival

-  everyday program
-  public inhabitants
-  private inhabitants
-  temporary structure



7

8

9

10

11

12

1

2

3

4

5

6

7

8

9

10

11

The Pond



7

8



9

10

11

12

1

2

3

4

5

6

7

8

9

10

11

Shops



-  everyday program
-  public inhabitants
-  private inhabitants
-  temporary structure

-  everyday program
-  public inhabitants
-  private inhabitants
-  temporary structure

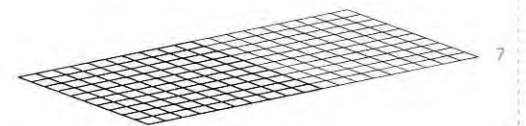

7

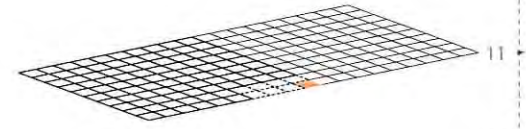

8

9

10

11

12

1

2

3

Shops

4

5

6

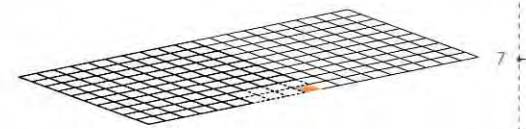

7

8

9

10

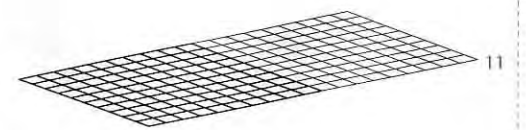

11

	public/private conflict	conflict with other program	weather	construction	quality of space	Program Matrix
Fashion Week	●	●	○	●	●	
Fall Festival	○	○	●	●	●	
Summer Film Festival	○	○	●	○	○	
The Pond	○	●	○	●	○	
Shops(winter)	●	○	○	●	○	
Yoga & Tai ChClasses	○	●	●	○	●	
Reading Room	○	○	●	●	●	
Wichcraft	○	○	○	○	○	
Southwest Porch	○	○	○	○	○	
The Bryant Park Grill and Café	○	○	○	○	○	

effective ●
ineffective ○

program / program



program / infrastructure

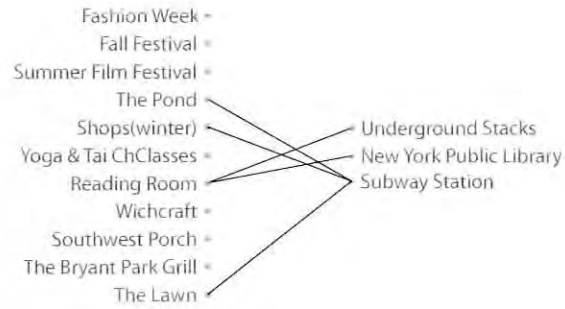

supporting program / everyday program

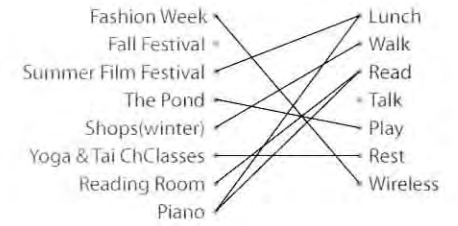

Bryant Park square footage	259,292 sq.ft.
Fashion Week	64,945 sq.ft.
Fall Festival	800 sq.ft.
Summer Film Festival	400 sq.ft.
The Pond	28,183 sq.ft.
Shops(winter)	15,625 sq.ft.
Yoga & Tai ChClasses	5,762 sq.ft.
Reading Room	3,135 sq.ft.
Wichcraft	625 sq.ft.
Southwest Porch	2,100 sq.ft.
The Bryant Park Grill and Café	6,370 sq.ft.

		program space	transformable space
Fashion Week	64,945 sq.ft.	64,945 sq.ft.	0 sq.ft.
The Pond	28,183 sq.ft.	53,705 sq.ft.	11,240 sq.ft.
Shops(winter)	15,625 sq.ft.		
Yoga & Tai ChClasses	5,762 sq.ft.		
Reading Room	3,135 sq.ft.		
Fall Festival	800 sq.ft.	9,697 sq.ft.	55,278 sq.ft.
Yoga & Tai ChClasses	5,762 sq.ft.		
Reading Room	3,135 sq.ft.		
Summer Film Festival	400 sq.ft.	9,297 sq.ft.	55,678 sq.ft.
Yoga & Tai ChClasses	5,762 sq.ft.		
Reading Room	3,135 sq.ft.		

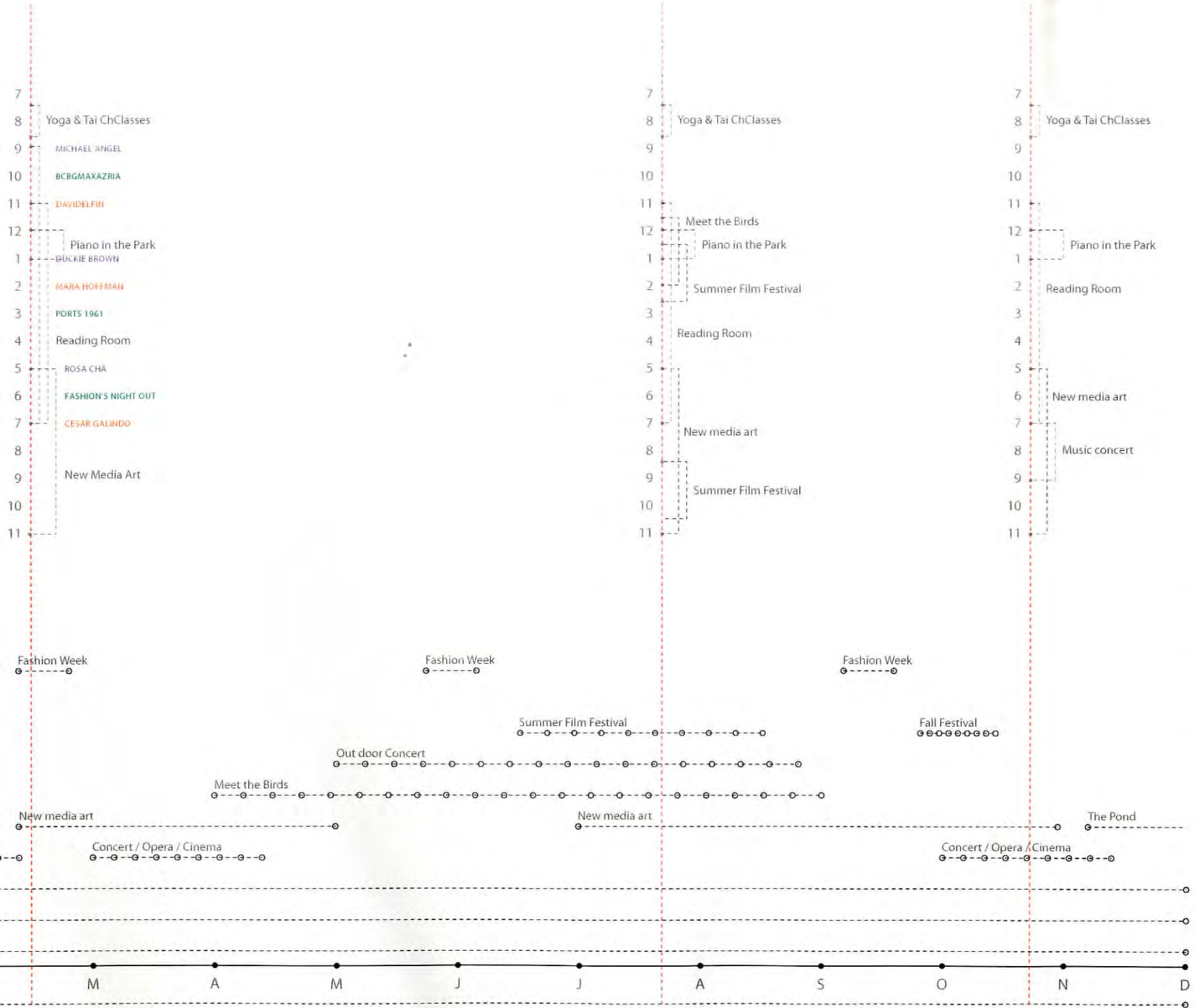

proposed calendar

- 7
- 8 Yoga & Tai Chi Classes
- 9 MICHAEL ANGEL
- 10 BCBGMAXAZRIA
- 11 DAVIDELHI
- 12 Piano in the Park
- 1 BUCKIE BROWN
- 2 MARA HOFFMAN
- 3 PORTS 1961
- 4 Reading Room
- 5 ROSA CHA
- 6 FASHION'S NIGHT OUT
- 7 CESAR GALINDO
- 8
- 9 New Media Art
- 10
- 11

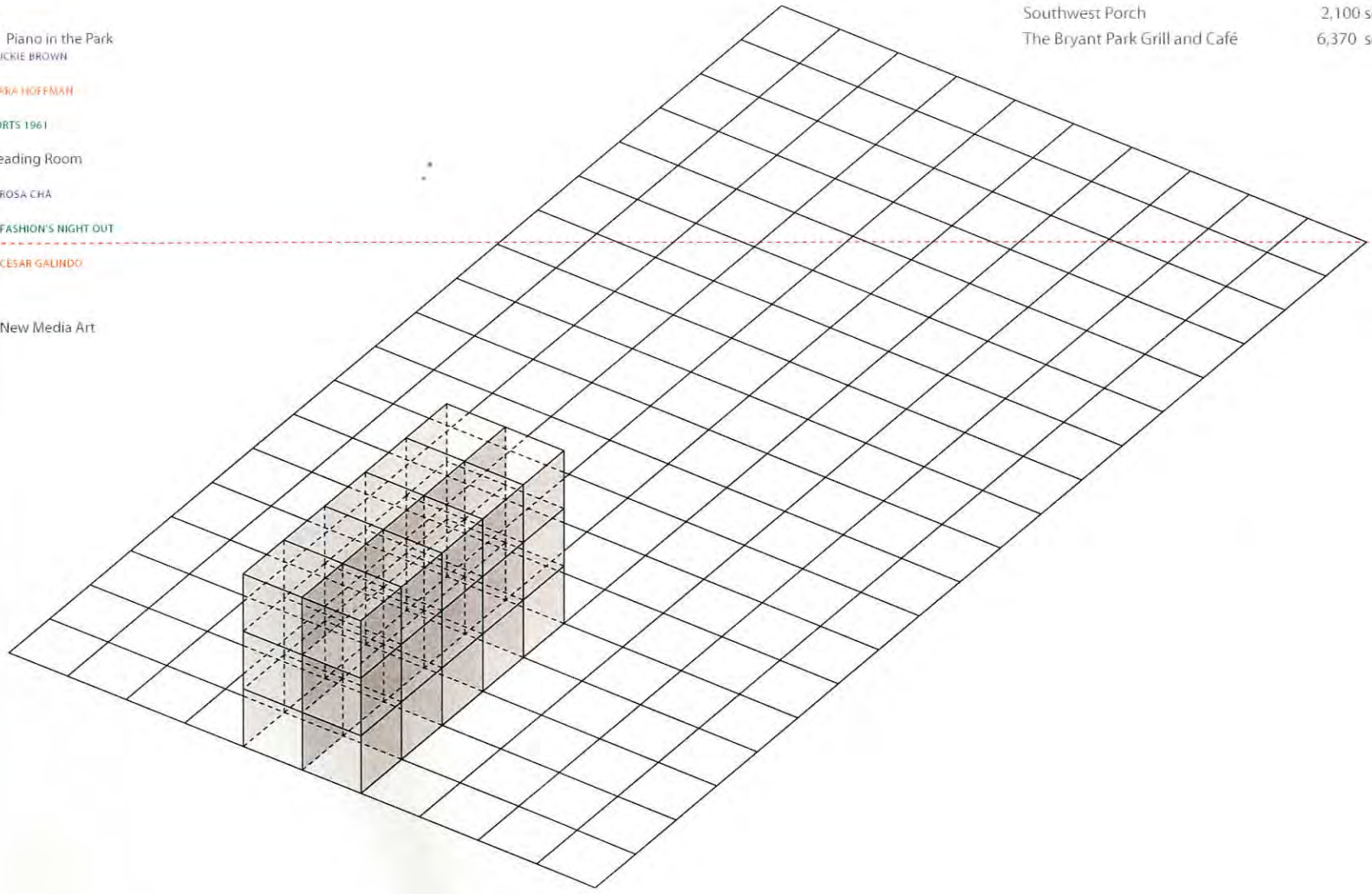

Bryant Park square footage	259,292 sq.ft.
Fashion Week	64,945 sq.ft.
Fall Festival	800 sq.ft.
Summer Film Festival	400 sq.ft.
The Pond	28,183 sq.ft.
Shops(winter)	15,625 sq.ft.
Yoga & Tai Chi Classes	5,762 sq.ft.
Reading Room	3,135 sq.ft.
Wichcraft	625 sq.ft.
Southwest Porch	2,100 sq.ft.
The Bryant Park Grill and Café	6,370 sq.ft.

- 7
- 8 Yoga & Tai Chi Classes
- 9 MICHAEL ANGEL
- 10 BCBGMAXAZRIA
- 11 DAVIDELFIN
- 12 Piano in the Park
- 1 BUCKIE BROWN
- 2 MARA HOFFMAN
- 3 PORTS 1961
- 4 Reading Room
- 5 ROSA CHA
- 6 FASHION'S NIGHT OUT
- 7 CESAR GALINDO
- 8
- 9 New Media Art
- 10
- 11

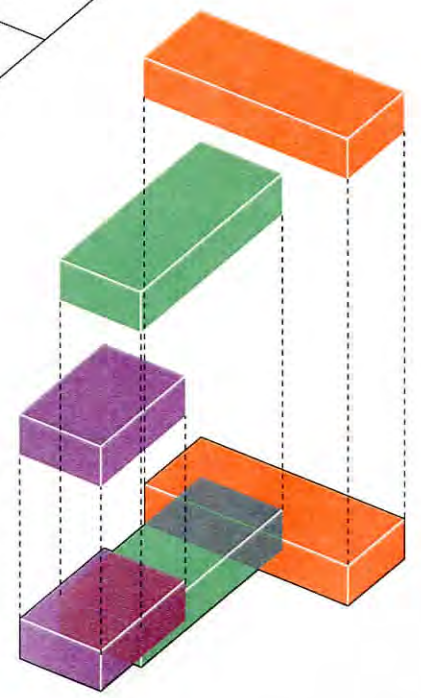
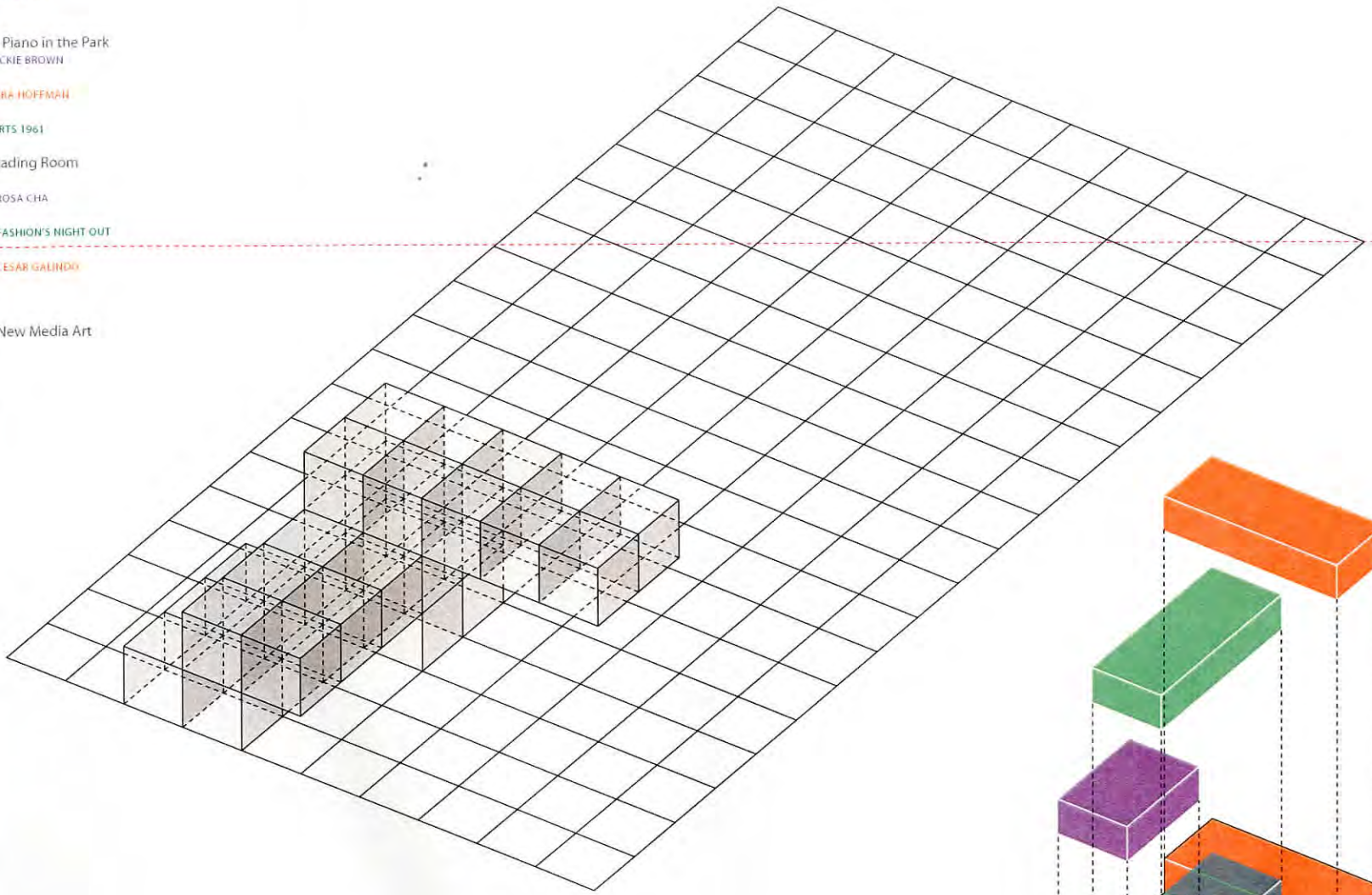

Bryant Park square footage	259,292 sq.ft.
Fashion Week	64,945 sq.ft.
Fall Festival	800 sq.ft.
Summer Film Festival	400 sq.ft.
The Pond	28,183 sq.ft.
Shops(winter)	15,625 sq.ft.
Yoga & Tai Chi Classes	5,762 sq.ft.
Reading Room	3,135 sq.ft.
Wichcraft	625 sq.ft.
Southwest Porch	2,100 sq.ft.
The Bryant Park Grill and Café	6,370 sq.ft.
Meet the Birds	1,000 sq.ft.
Piano in the Park	200 sq.ft.

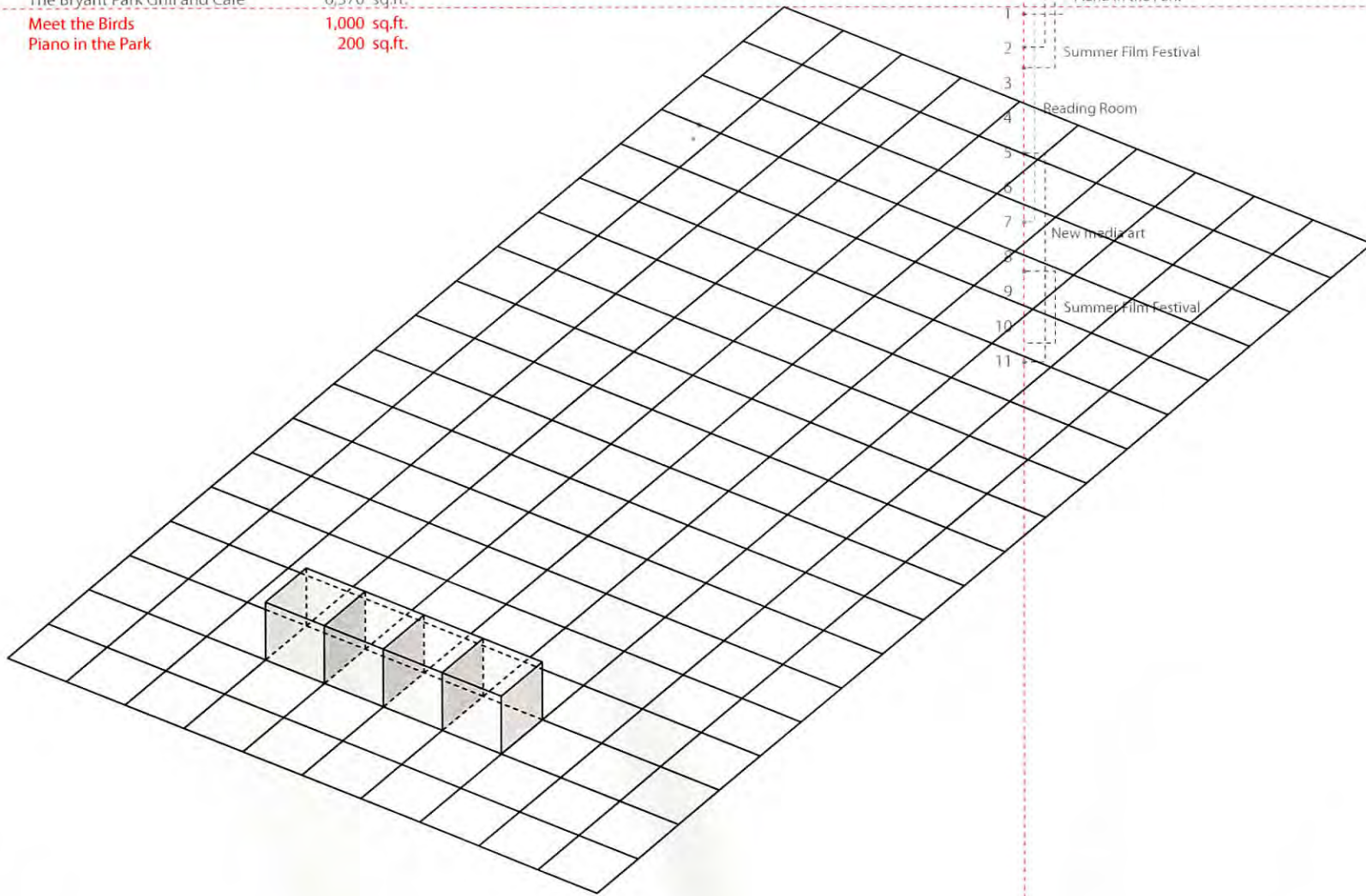

- 7
- 8 Yoga & Tai Chi Classes
- 9
- 10
- 11
- 12 Meet the Birds
- Piano in the Park
- 1
- 2 Summer Film Festival
- 3 Reading Room
- 4
- 5
- 6
- 7 New media art
- 8 Summer Film Festival
- 9
- 10
- 11

Transformable Space

200 sq.ft.

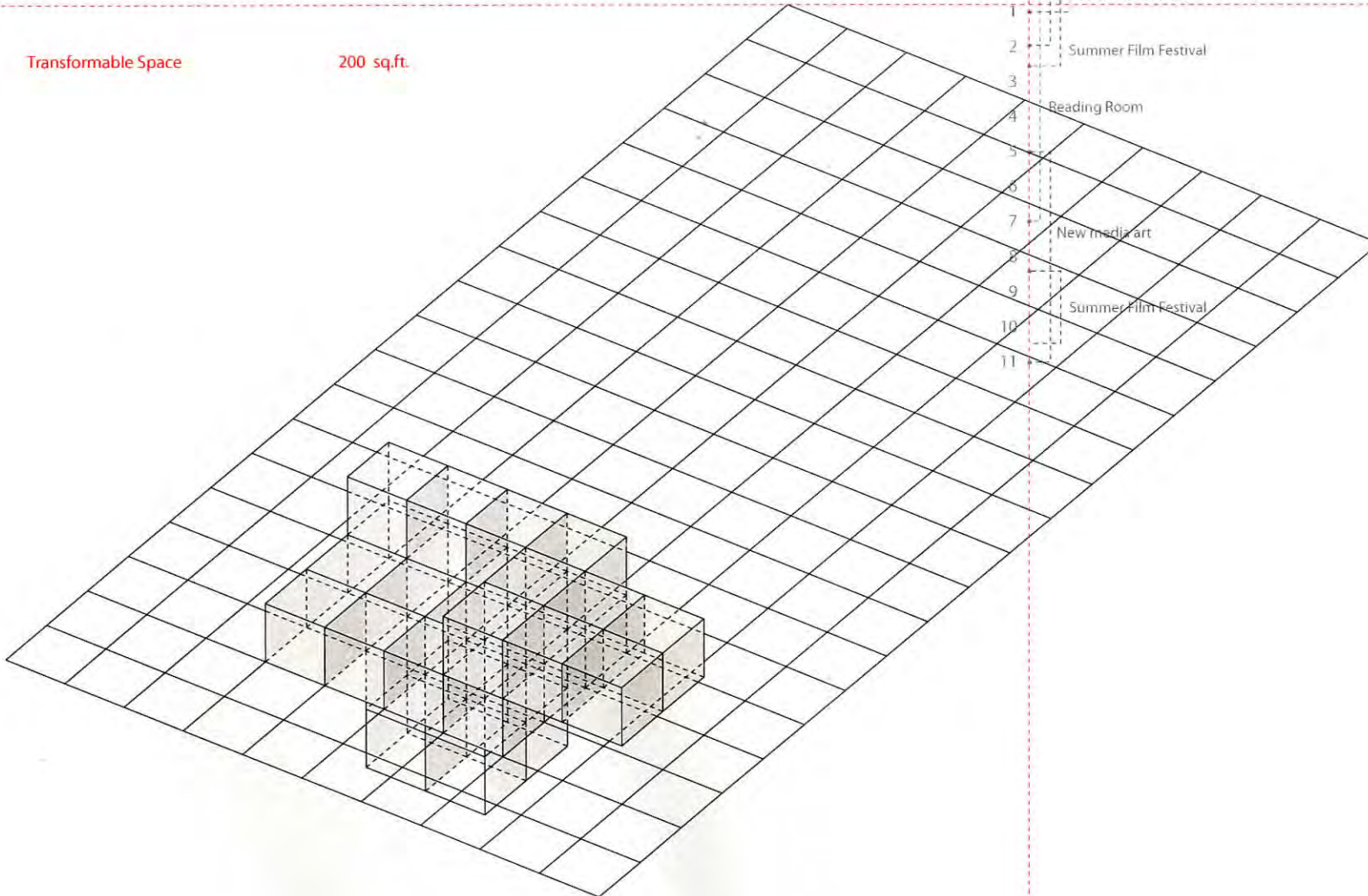

- 7
- 8 Yoga & Tai Chi Classes
- 9
- 10
- 11
- 12 Meet the Birds
- 1 Piano in the Park
- 2 Summer Film Festival
- 3
- 4 Reading Room
- 5
- 6
- 7 New media art
- 8
- 9 Summer Film Festival
- 10
- 11



Fashion Exhibition



Art Exhibition



Cinema



Special Event

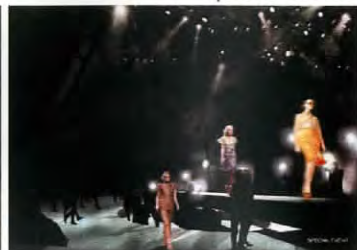

PRADA TRANSFORMER

Prada Transformer is a pioneering temporary structure picked up by cranes and rotated to accommodate a variety of cultural events. The 20-metre high Prada Transformer is located adjacent to the 16th Century Gyeonghui Palace in the centre of Seoul. The pavilion consists of four basic geometric shapes – a circle, a cross, a hexagon, a rectangle – leaning together and wrapped in a translucent membrane.

Each shape is a potential floor plan designed to be ideal for three months of cultural programming: a **fashion exhibition** (Waist Down, featuring skirts designed by Miuccia Prada), a **film festival** (co-curated by Alejandro González Iñárritu), an **art exhibition** (by Swedish video artist and sculptor Nathalie Djurberg), and a **Prada fashion show**. Walls become floors and floors become walls as the pavilion is flipped over by three cranes after each event to accommodate the next.

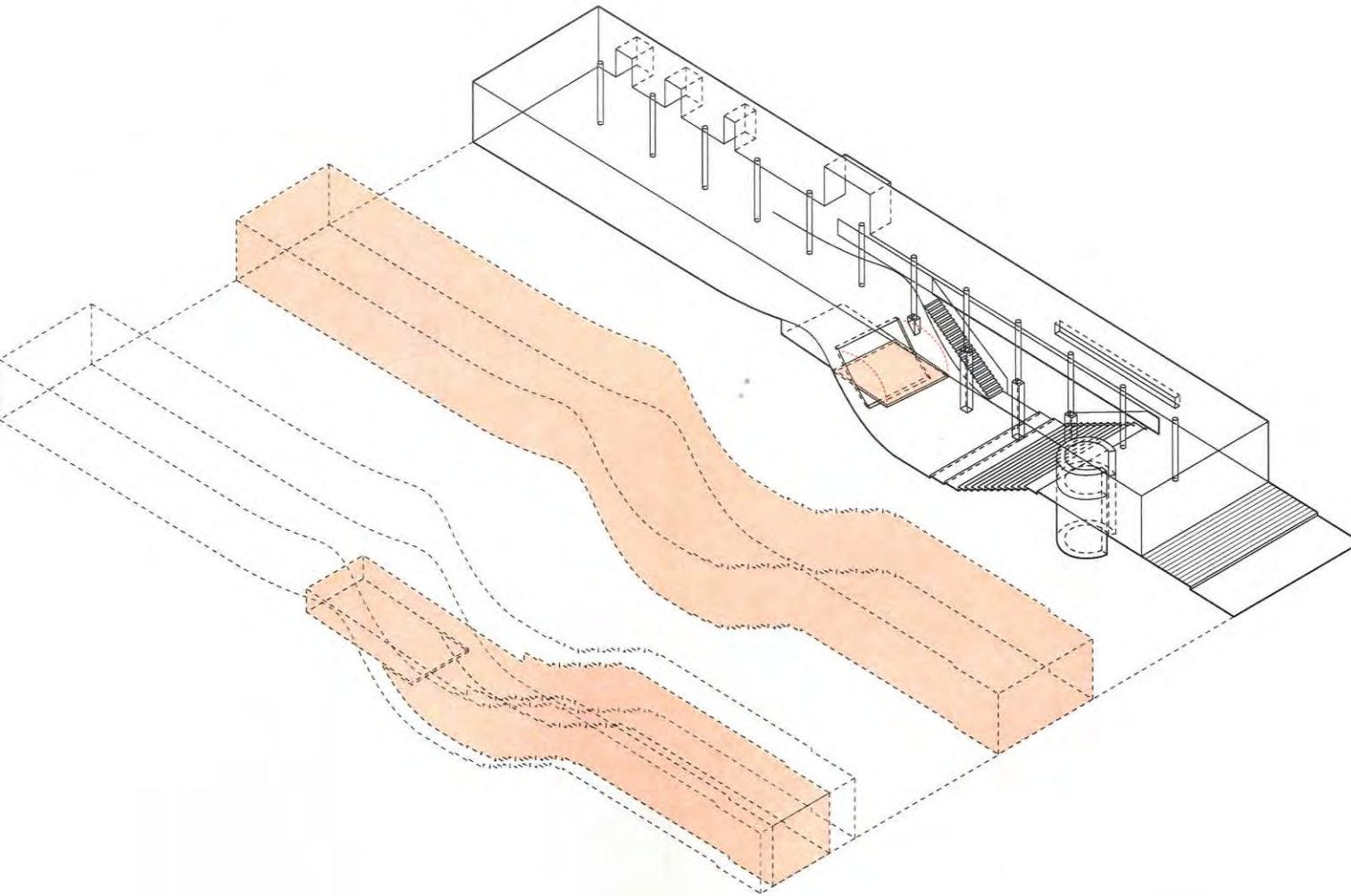

PRADA STORE SOHO

As a means to naturally connect to the large basement area and guide customers to the more invisible parts of the store, the floor steps downwards in its entire width and rises subsequently to re-connect to the ground level, creating a big 'wave'. The oversized stair made of zebra wood is used as an informal display space, where people can try on shoes and browse through bags and other accessories. At the push of a button, an event platform rotates out of the opposite part of the wave, turning the stair into an auditorium for **performances, film projections, and lectures**. Large metal cages for merchandise and displays are suspended from an overhead track system and create singular shopping addresses, like inverted buildings in a street – a 'hanging city'. These display volumes can contract at the back of the store into a solid volume and free the space for public activities.



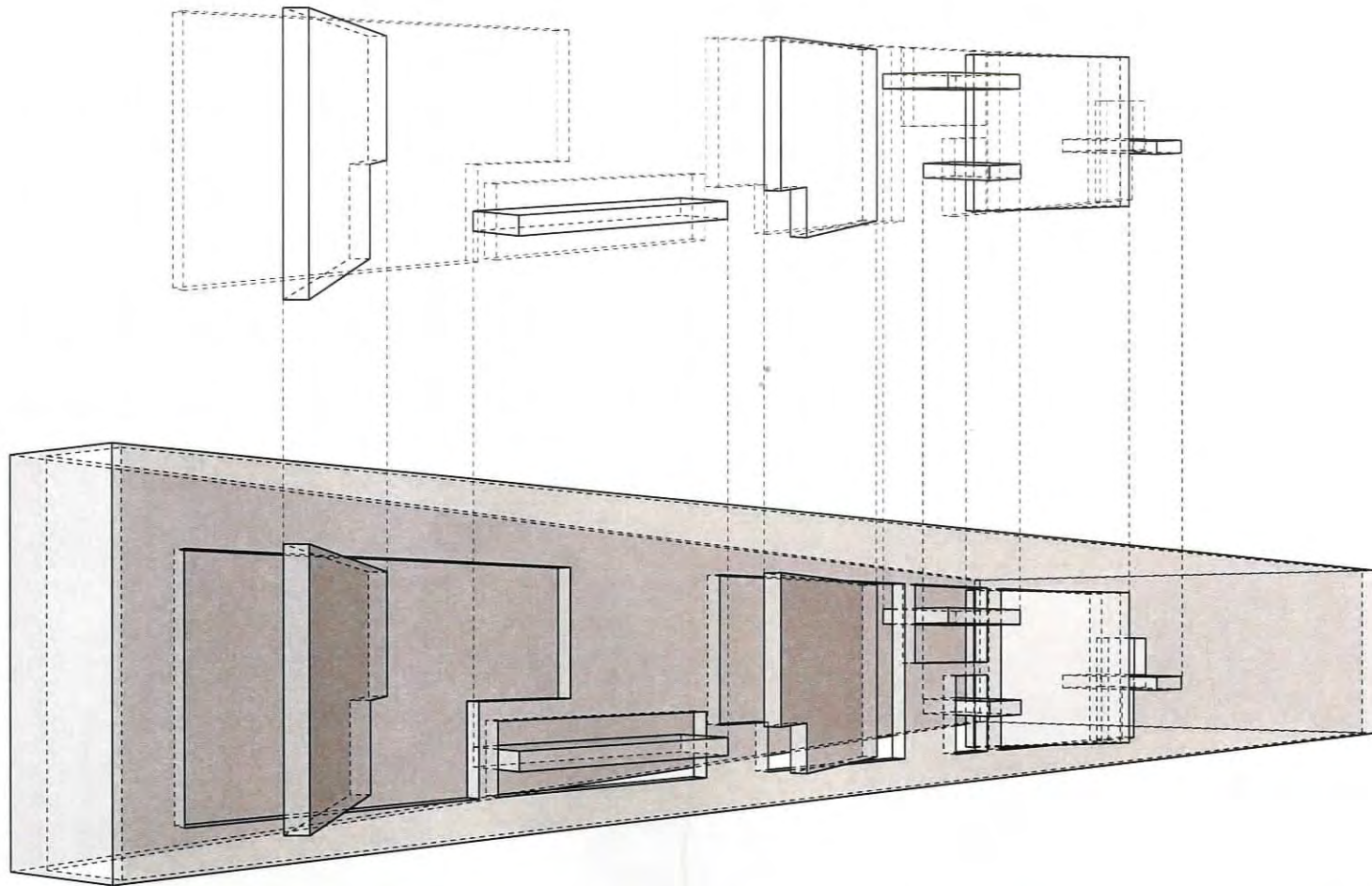

STOREFRONT FOR ART AND ARCHITECTURE

VERTICAL TRANSFORMATION &
HORIZONTAL TRANSFORMATION
OF THE SURFACE



HORIZONTAL TRANSFORMATION
OF THE SPACE

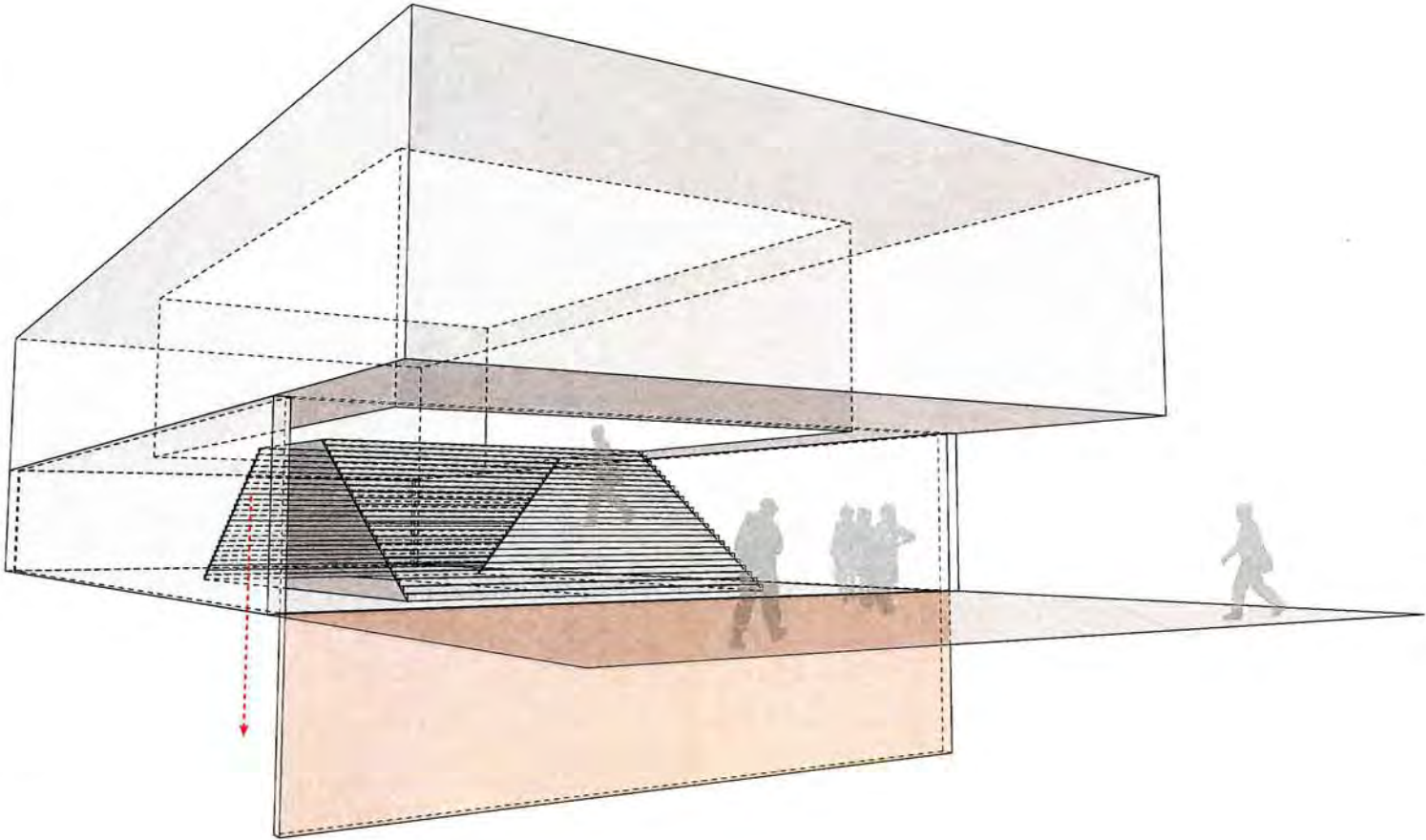

PRADA STORE LA
VERTICAL TRANSFORMATION
OF THE SURFACE

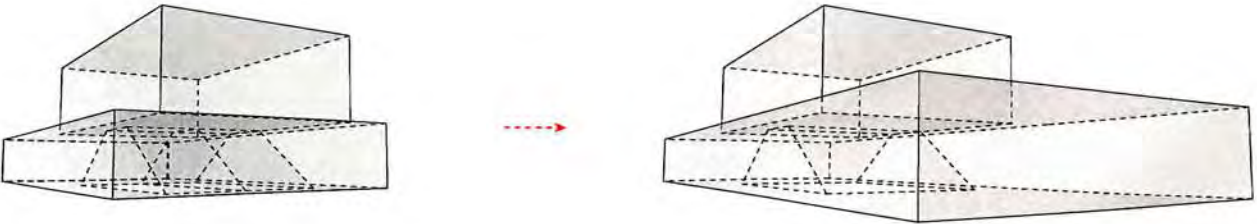

HORIZONTAL TRANSFORMATION
OF THE SPACE

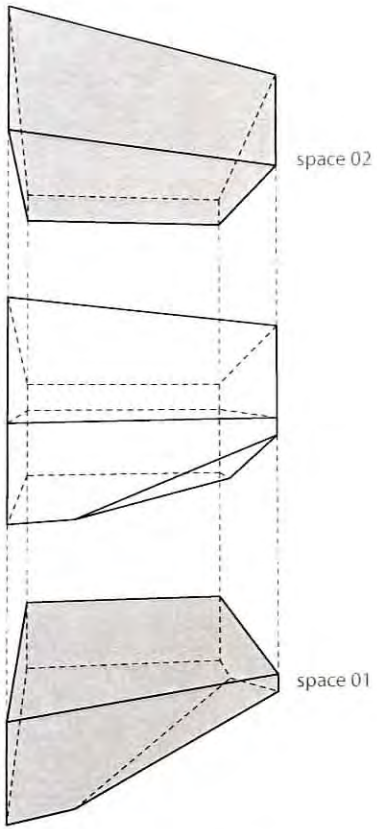

basic form

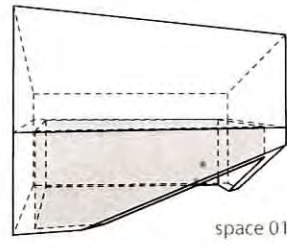

space 01

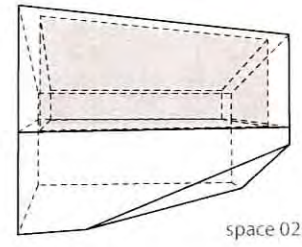

space 02

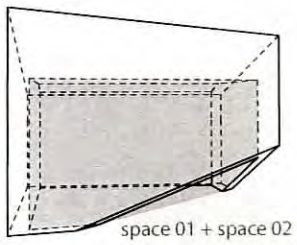

space 01 + space 02

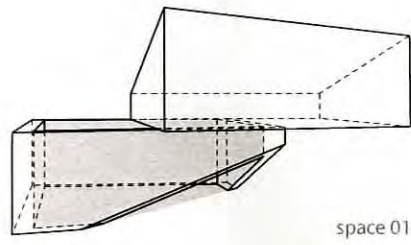

space 01

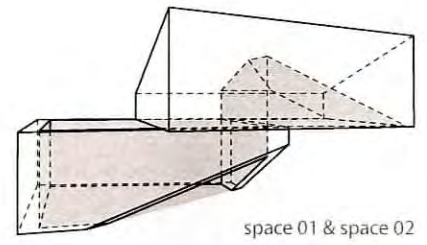

space 01 & space 02

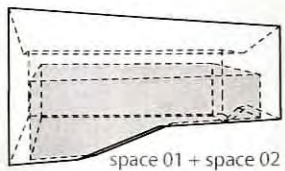

space 01 + space 02

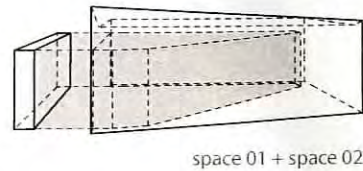

space 01 + space 02

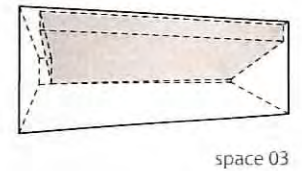

space 03

SPACE MATRIX

- space 01 + space 02 + space03
- space 01 + space 02 & space03
- space 01 + space 02
- space 01 + space03 & space02
- space 01 + space03
- space 02 + space03 & space01
- space 02 + space03

Building Techniques : **sliding** / splitting / collapsing

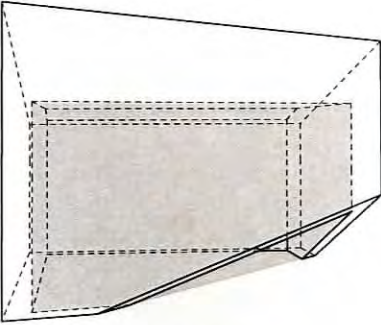

Fall Festival (stage)

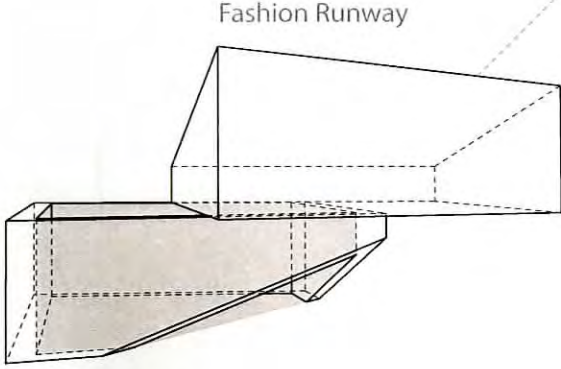

Fashion Runway

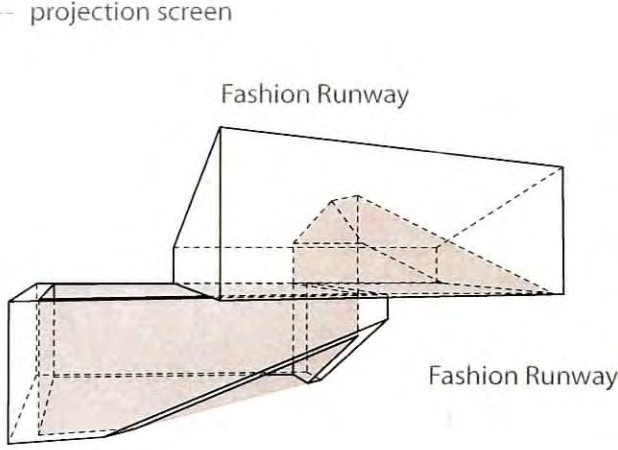

Fashion Runway

Building Techniques : sliding / splitting / collapsing

program / infrastructure

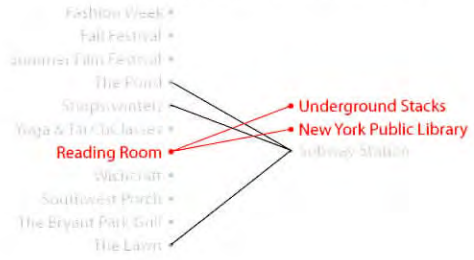

building techniques



Yoga & Tai Chi Classes (platform)

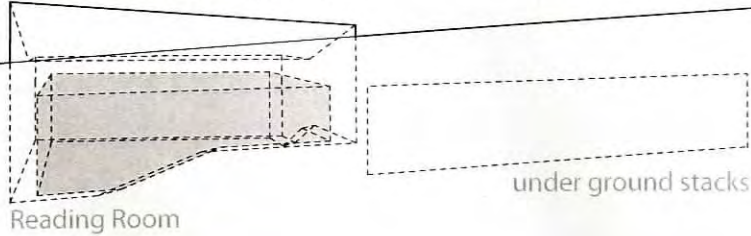

Reading Room

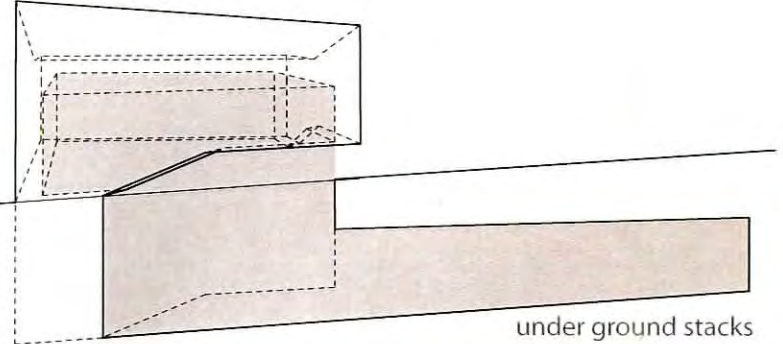

Supporting Program

Fashion Week / Summer Film Festival / The Pond / Reading Room / Fall Festival / Reading Room / Yoga & Tai Chi Classes / Piano in the park / New Media

Everyday Program

Eat / Walk / Read / Talk / Play / Rest / Wifi

accessible
restricted

Summer Film Festival / Reading Room / Fall Festival / Reading Room / Yoga & Tai Chi Classes / Piano in the park / New Media / Concert / Cinema / Opera
Fashion Week / The Pond / New Media / Concert / Cinema / Opera

Everyday Supporting Program

Reading Room / Yoga & Tai Chi Classes / Piano in the park

Weekly Supporting Program

Fashion Week / Concert / Cinema / Opera

Seasonal Supporting Program

Summer Film Festival / The Pond / Fall Festival / New Media

Supporting Program

Fashion Week / Summer Film Festival / The Pond / Reading Room / Fall Festival / Reading Room / Yoga & Tai Chi Classes / Piano in the park

Program Program matrix :

Fashion Week	+	Reading Room
Fashion Week	+	Summer Film Festival
Summer Film Festival	+	Reading Room
Reading Room	+	Fall Festival
The Pond	+	Summer Film Festival
The Pond	+	Shops(winter)

Fashion Week	+	Summer Film Festival	+	Reading Room		
Reading Room	+	Fashion Week	+	Fall Festival		
Summer Film Festival	+	Fashion Week	+	The Pond	+	Reading Room

Program infrastructure matrix

Reading Room	+	NY Public Library				
Reading Room	+	Subway Station				
Subway Station	+	The Pond				
Reading Room	+	Fashion Week	+	Fall Festival	+	NY Public Library

Everyday Program

Eat / Walk / Read / Talk / Play / Rest / Wireless

- SPACETIME combines space and time to a single abstract "space"**
 Dimensions are independent components of a coordinate grid needed to locate a point in a certain defined "space". For example, on the globe the latitude and longitude are two independent coordinates which together uniquely determine a location. In spacetime, a coordinate grid that spans the 3+1 dimensions locates events (rather than just points in space), i.e. time is added as another dimension to the coordinate grid. This way the coordinates specify where and when events occur.
- Sensibility of Space**
 Perception or responsiveness toward space.

program structure

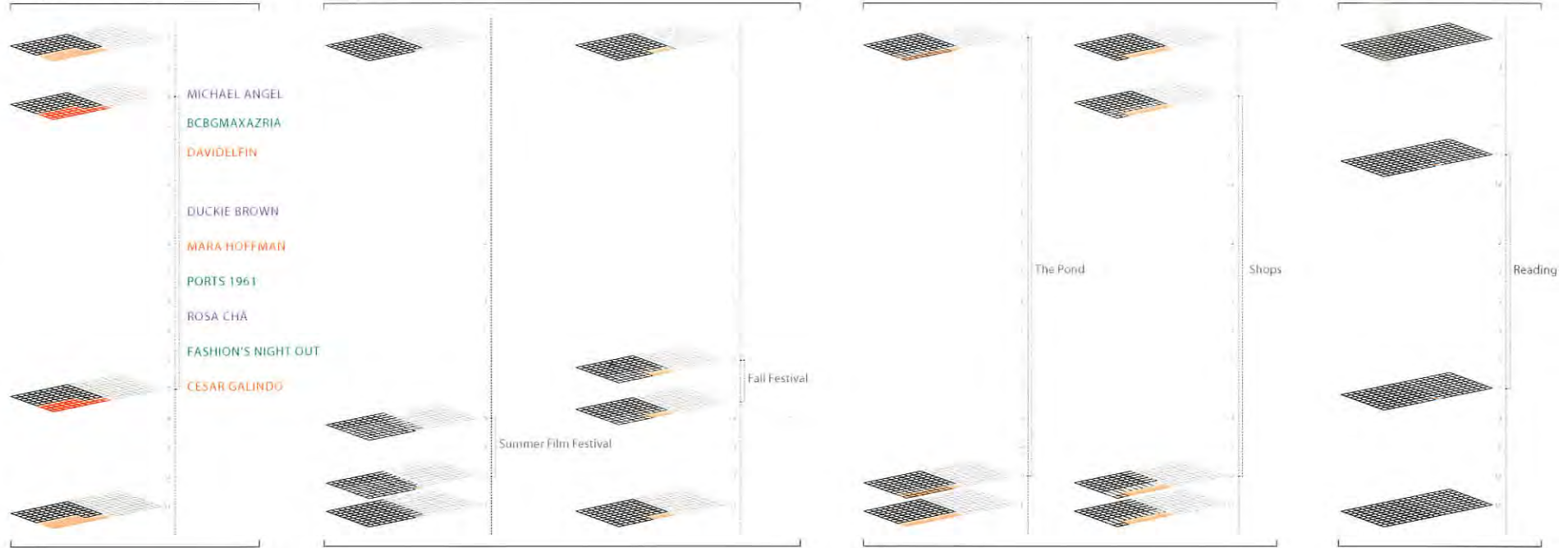

- everyday program
- public inhabitants
- private inhabitants
- temporary structure

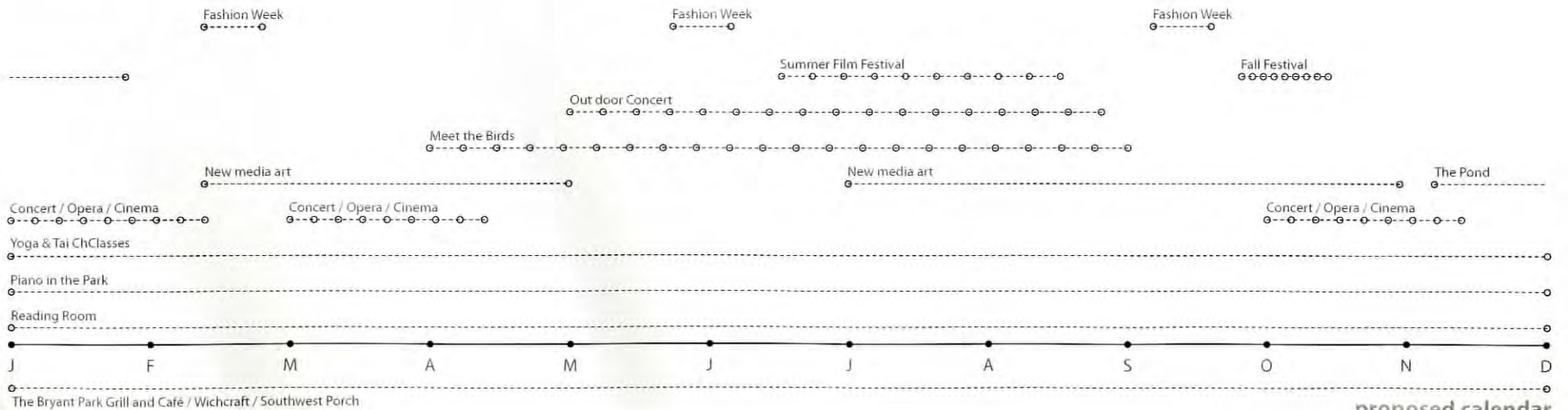

proposed calendar

The Bryant Park Grill and Café / Wichcraft / Southwest Porch

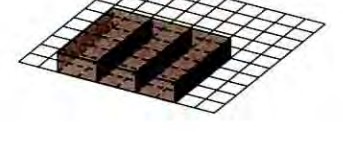
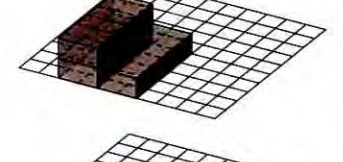
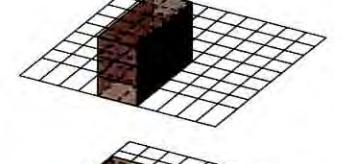
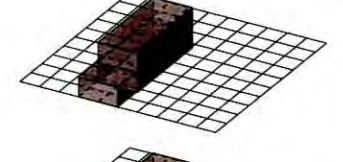
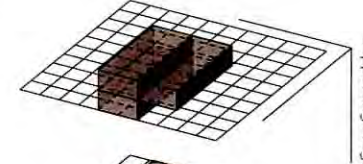
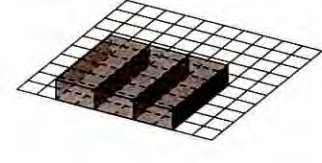
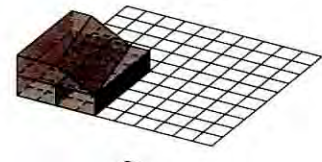
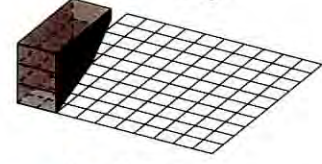
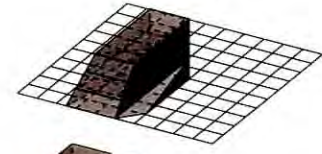
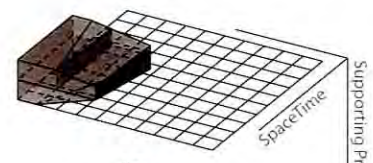
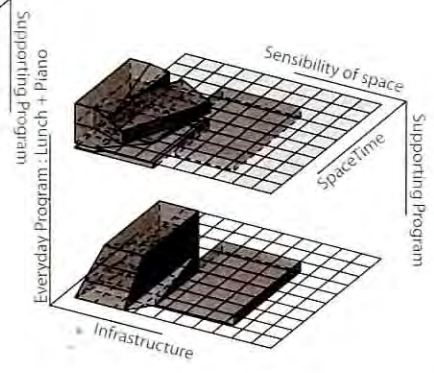
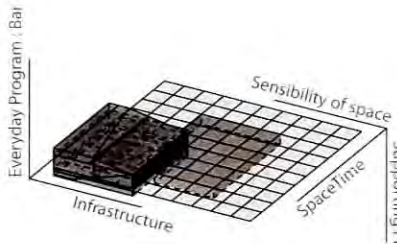

Supporting Program
Fashion + Reading Room
Fashion
Fashion

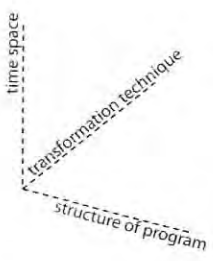
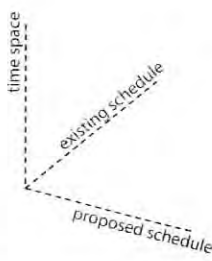
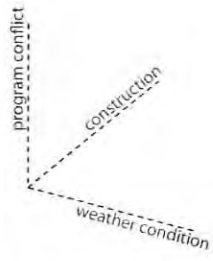
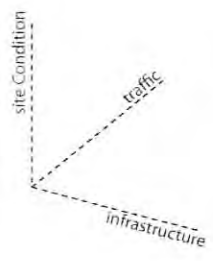
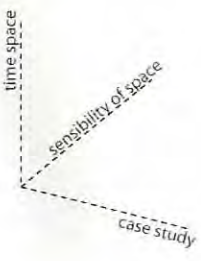
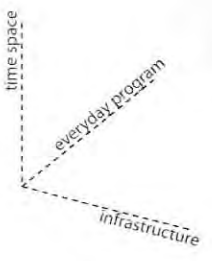
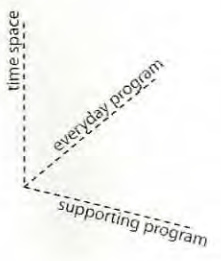
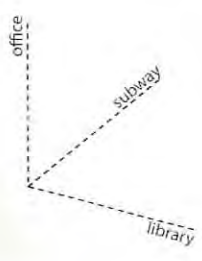
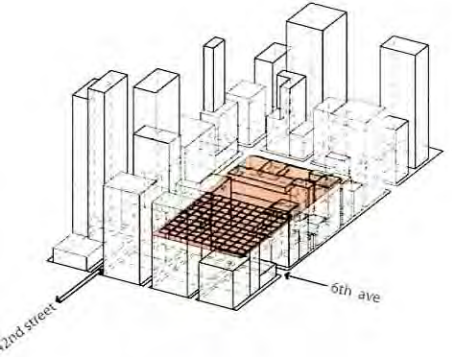

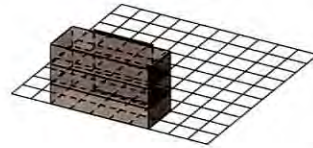
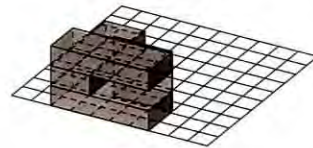
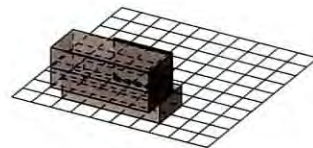
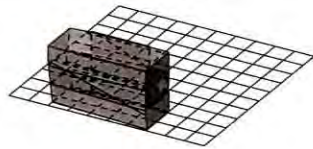
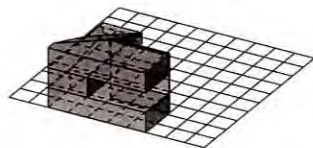
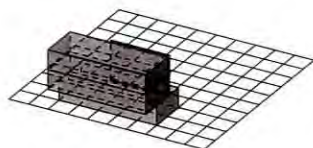
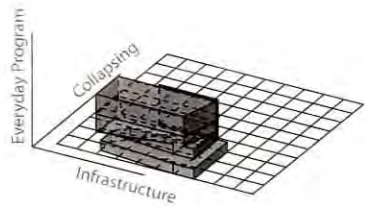
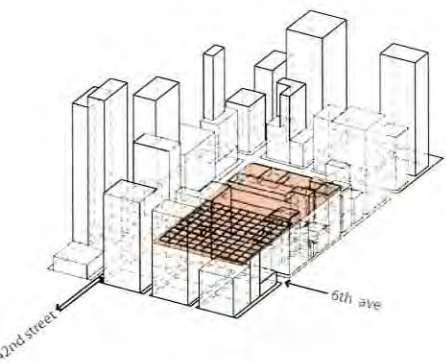

Fashion + Reading Room
+ Summer Film Festival
+ Fashion + Reading Room
+ Summer Film Festival
+ Fashion + Reading Room
+ Summer Film Festival

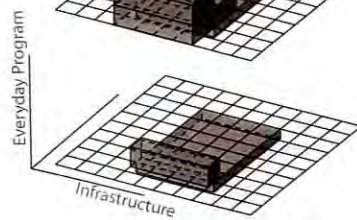
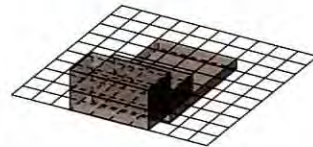
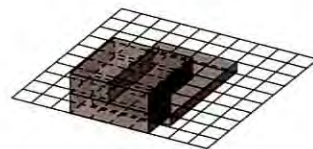
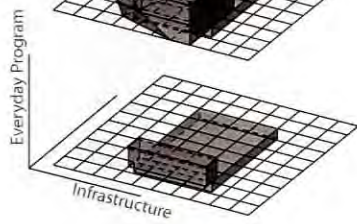
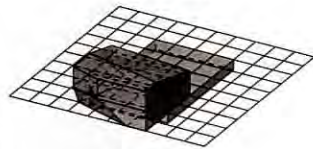
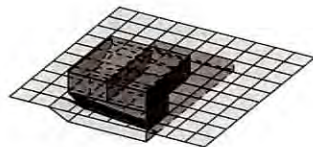
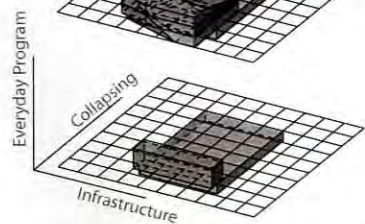
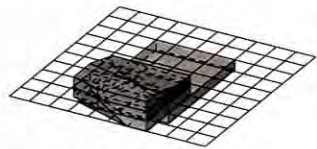
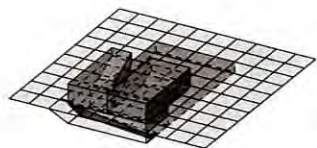

Fashion + Reading Room
+ Fall Festival
+ Fashion + Reading Room
+ Fall Festival
+ Fashion + Reading Room
+ Fall Festival

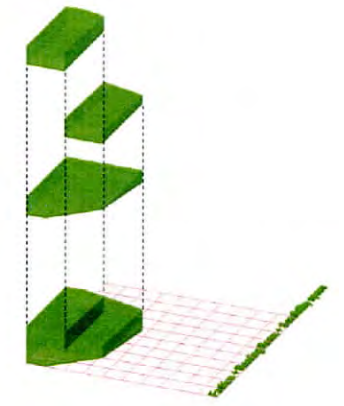
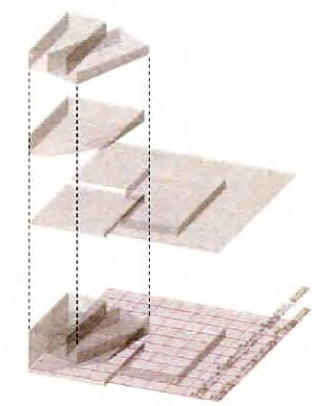
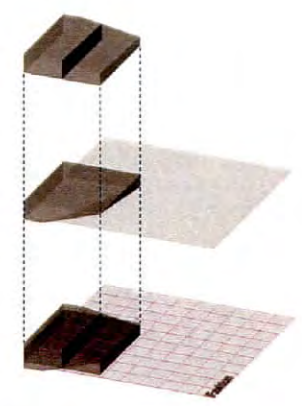
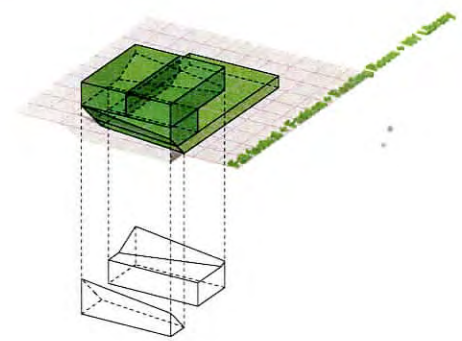
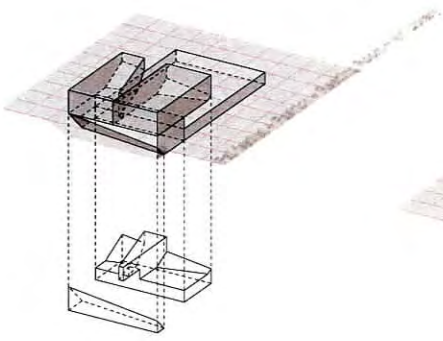

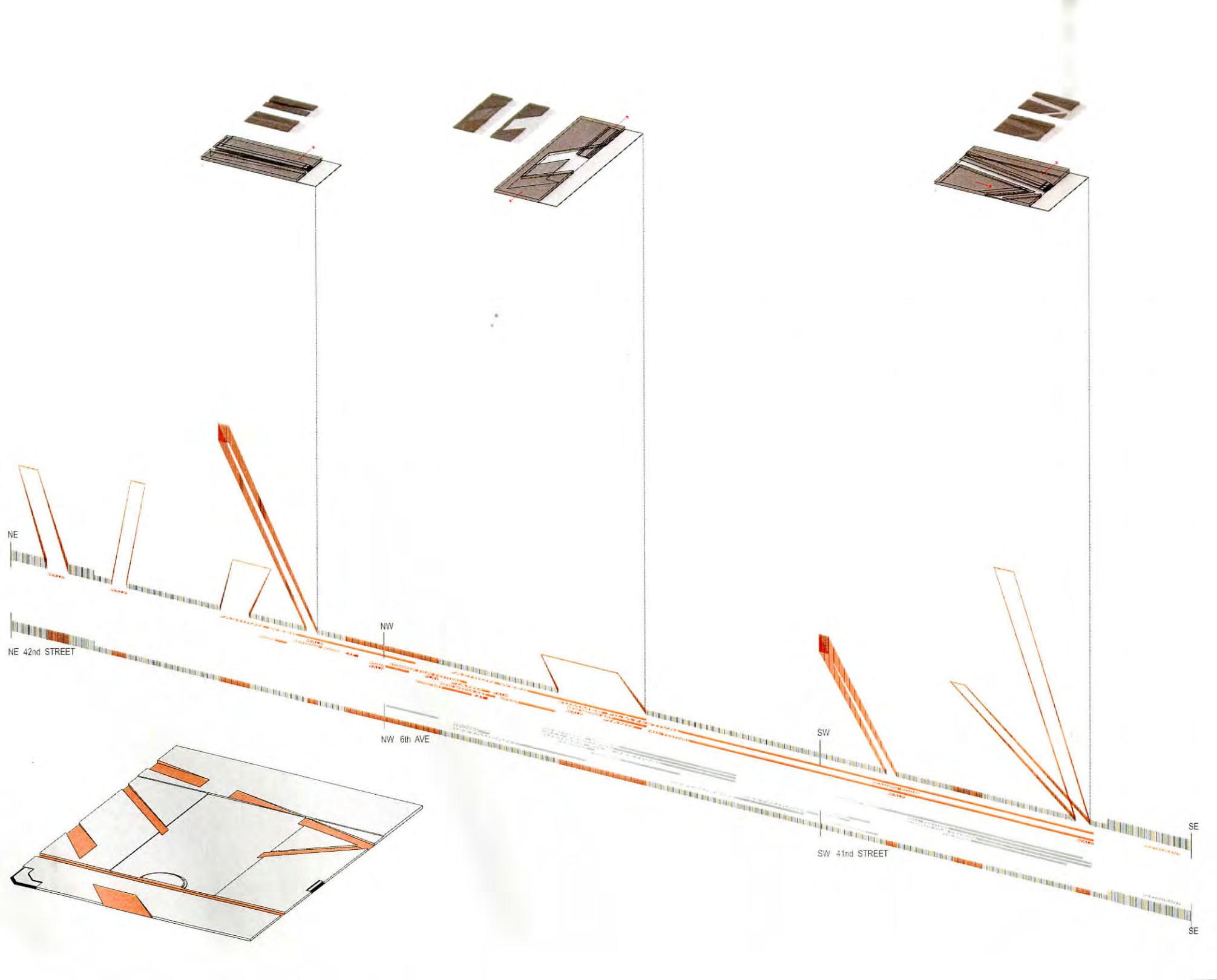

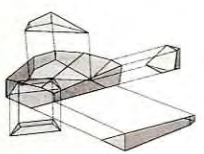
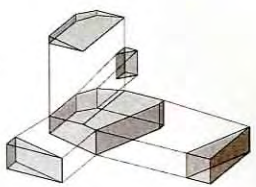
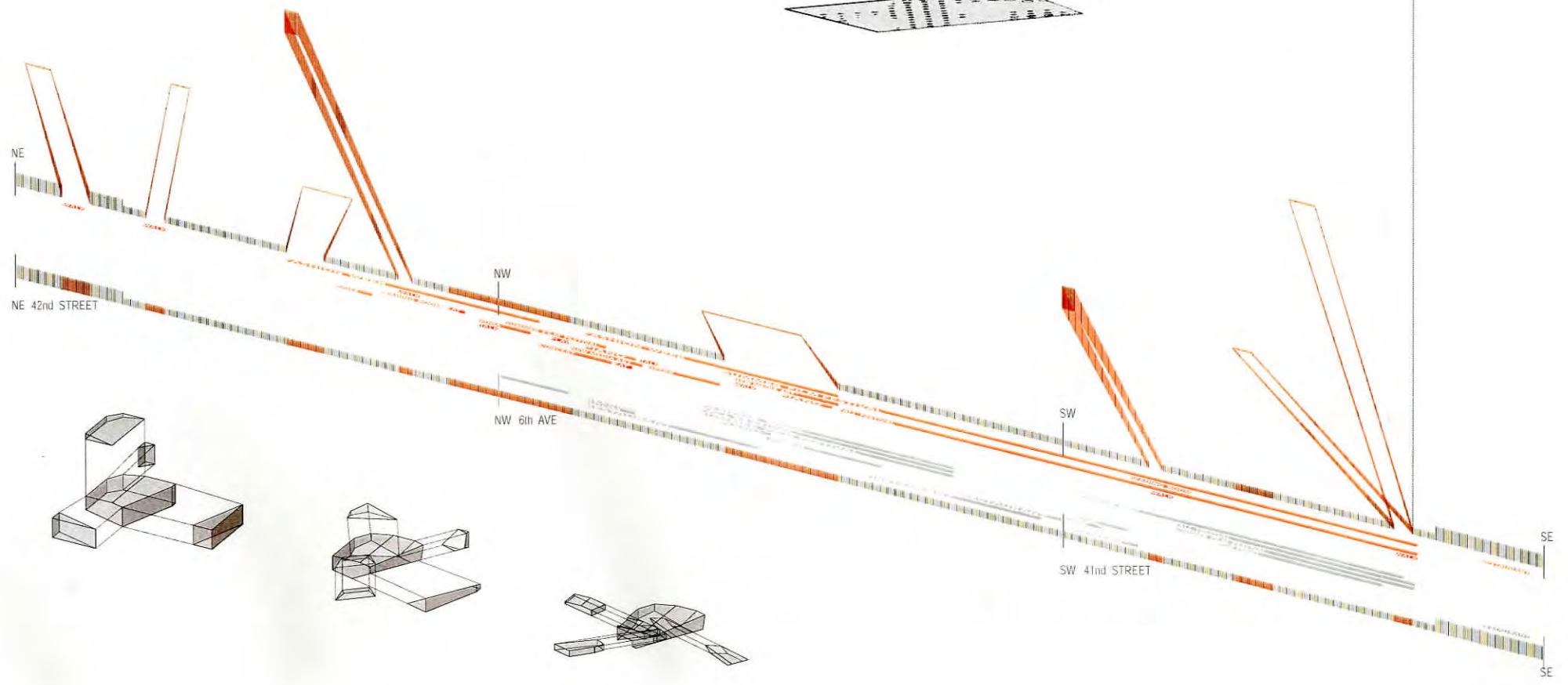
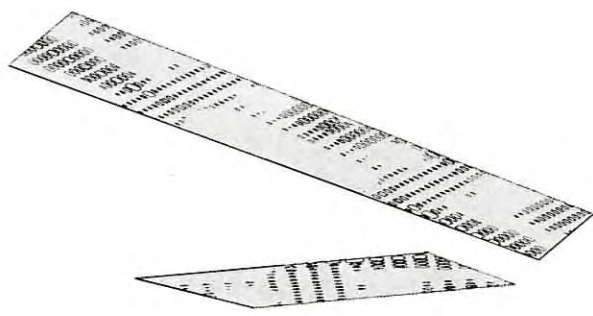
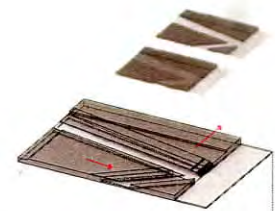

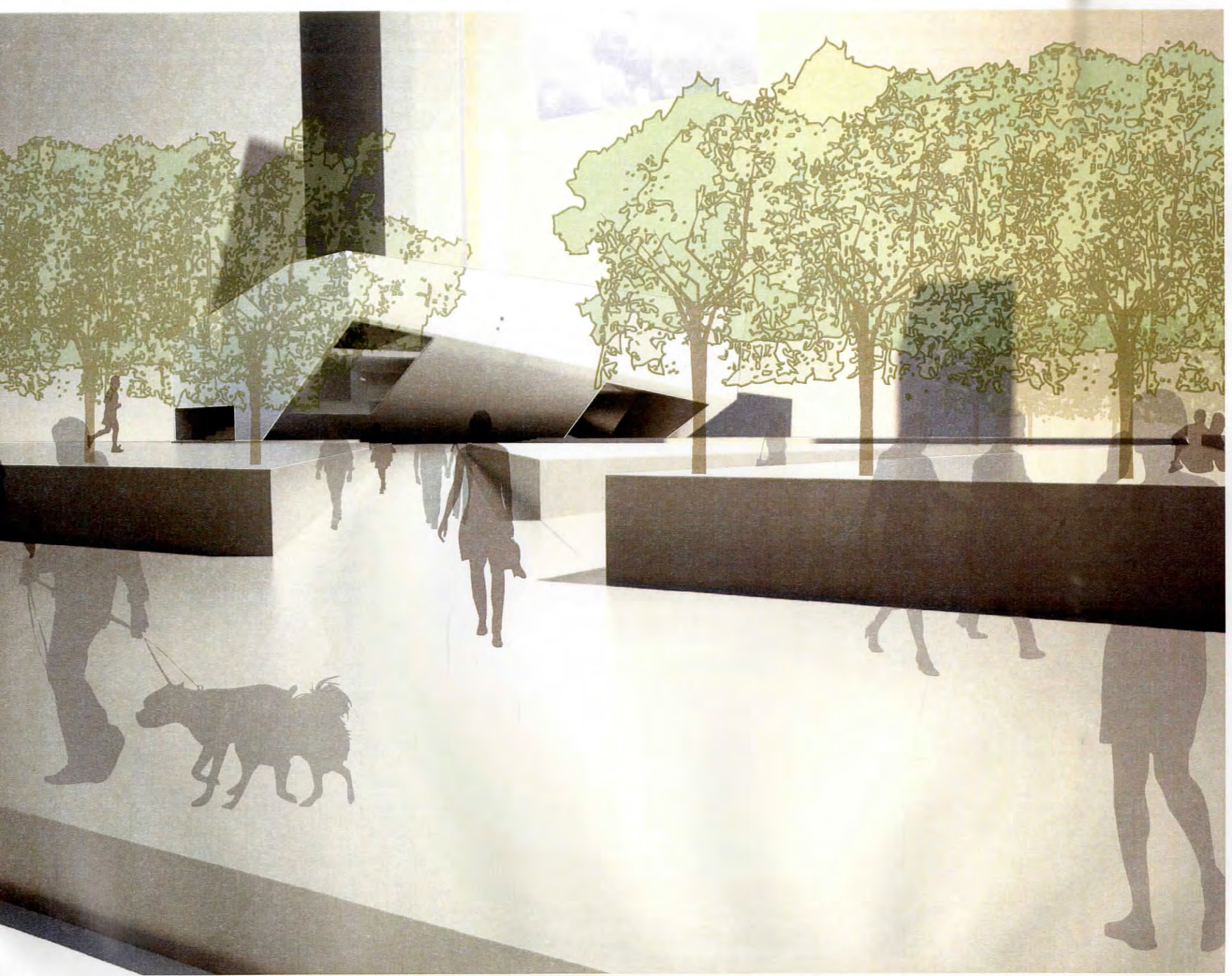

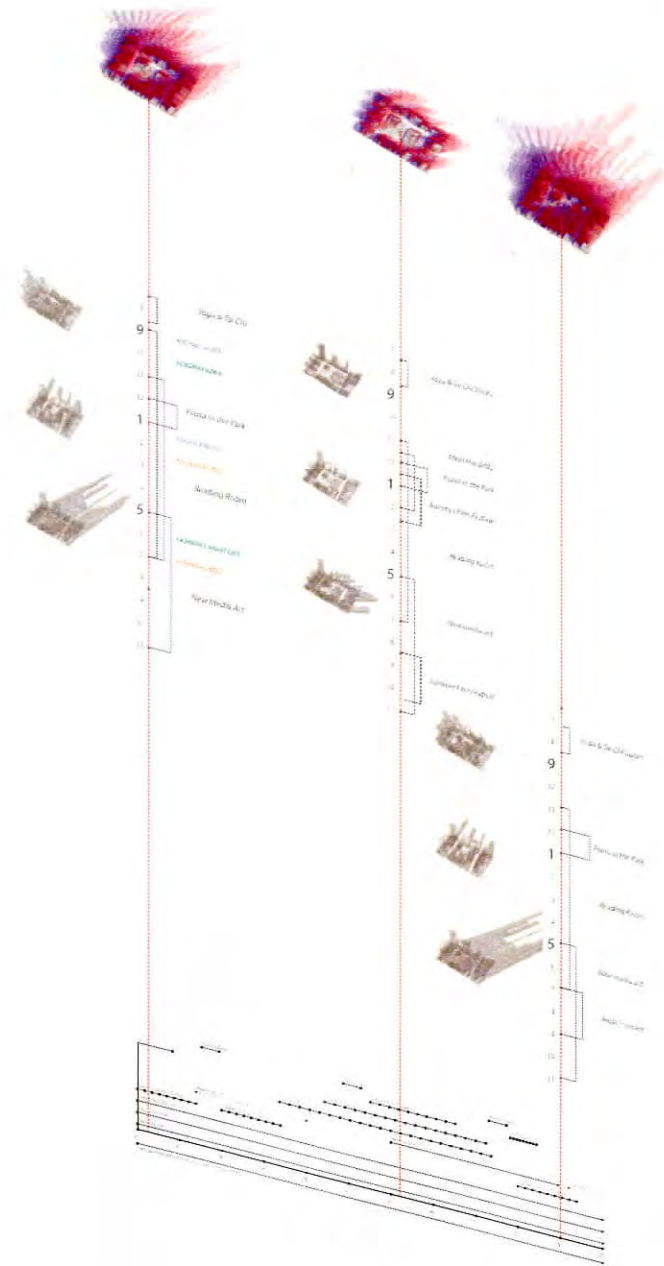
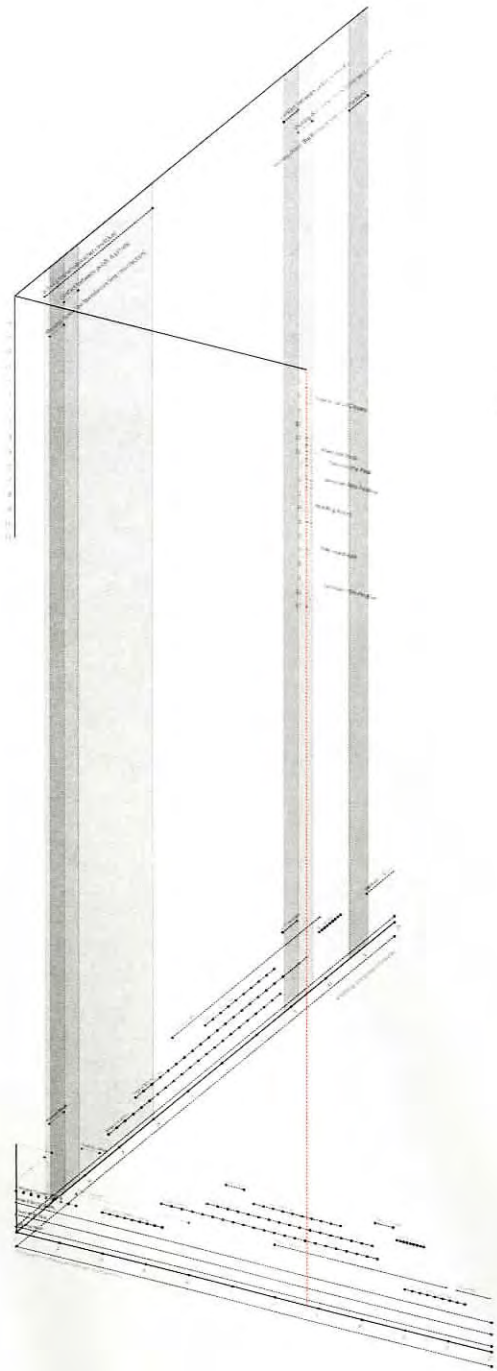

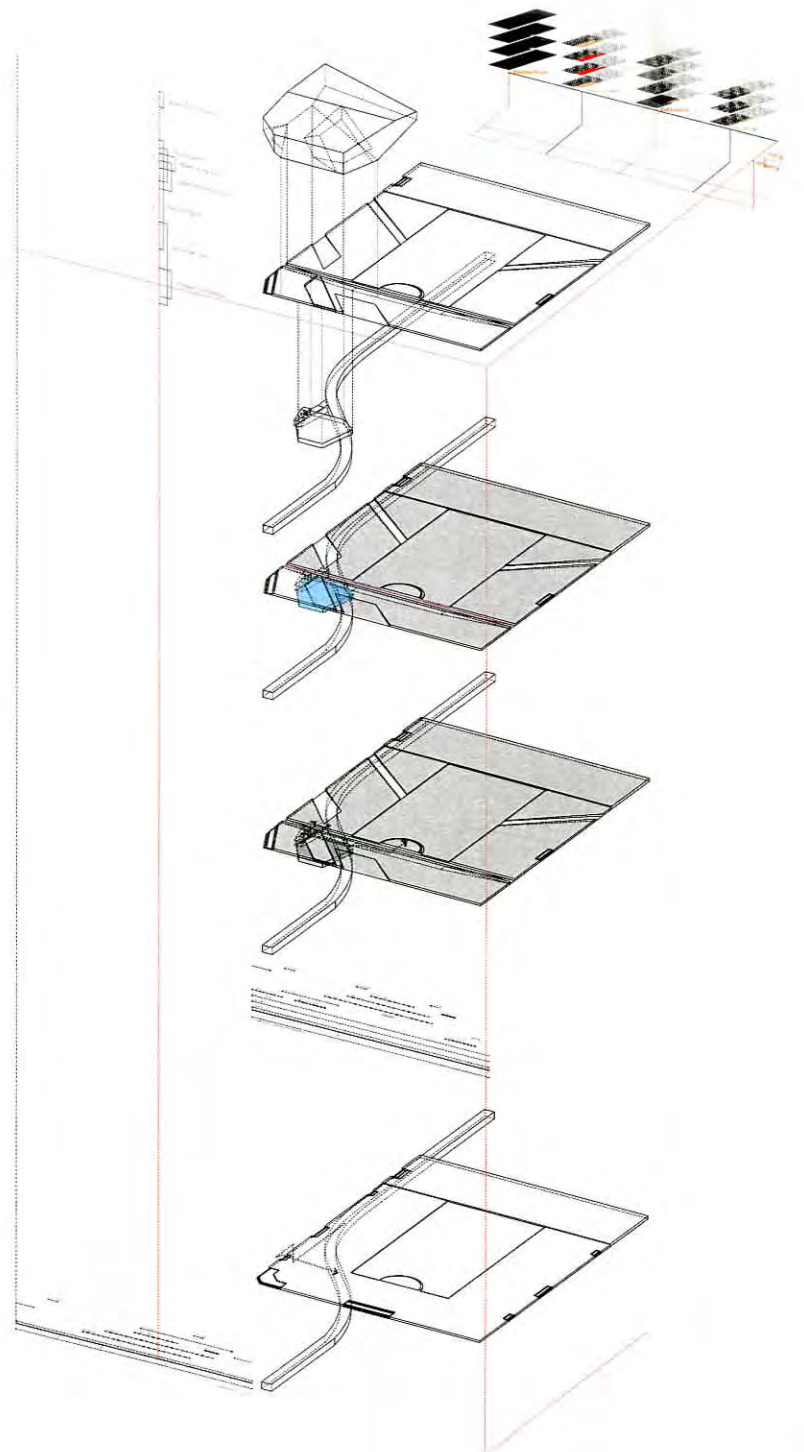
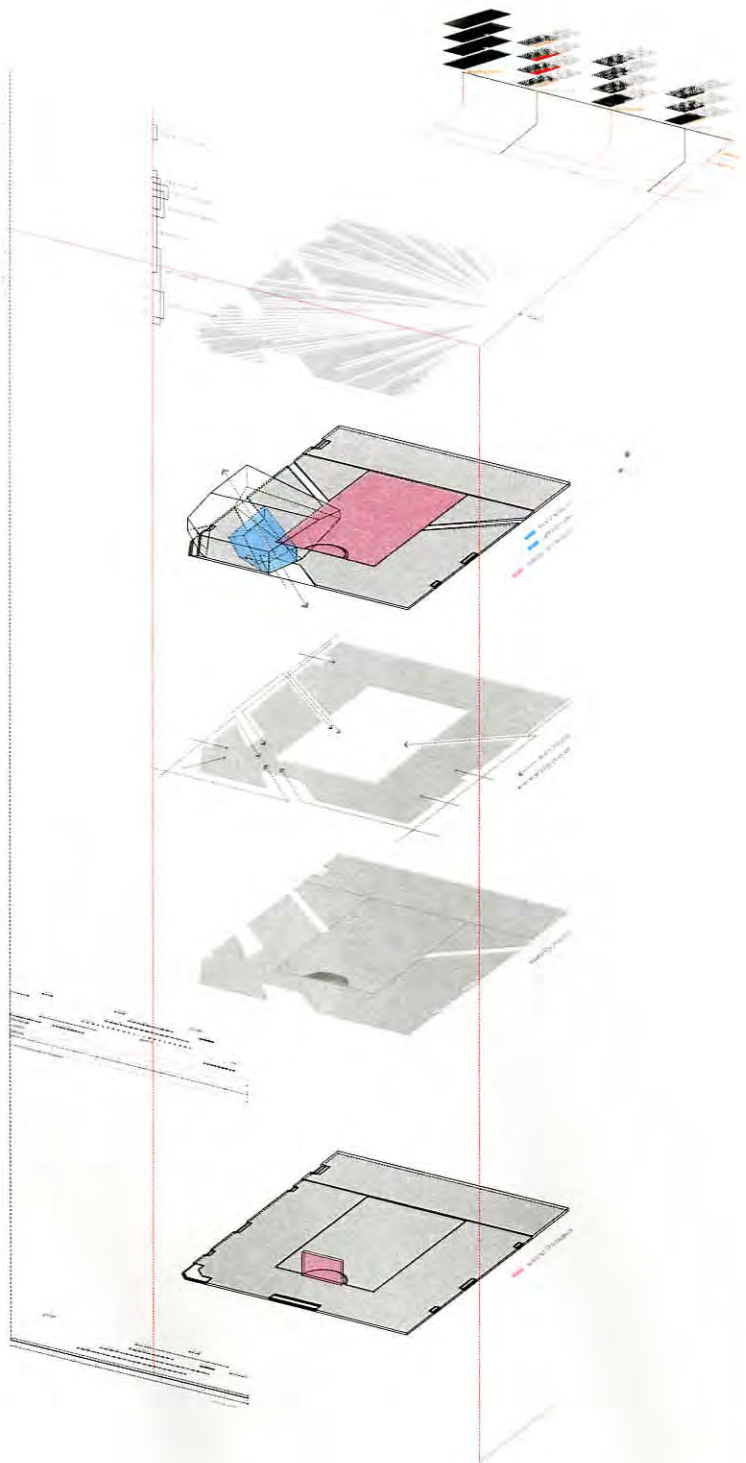

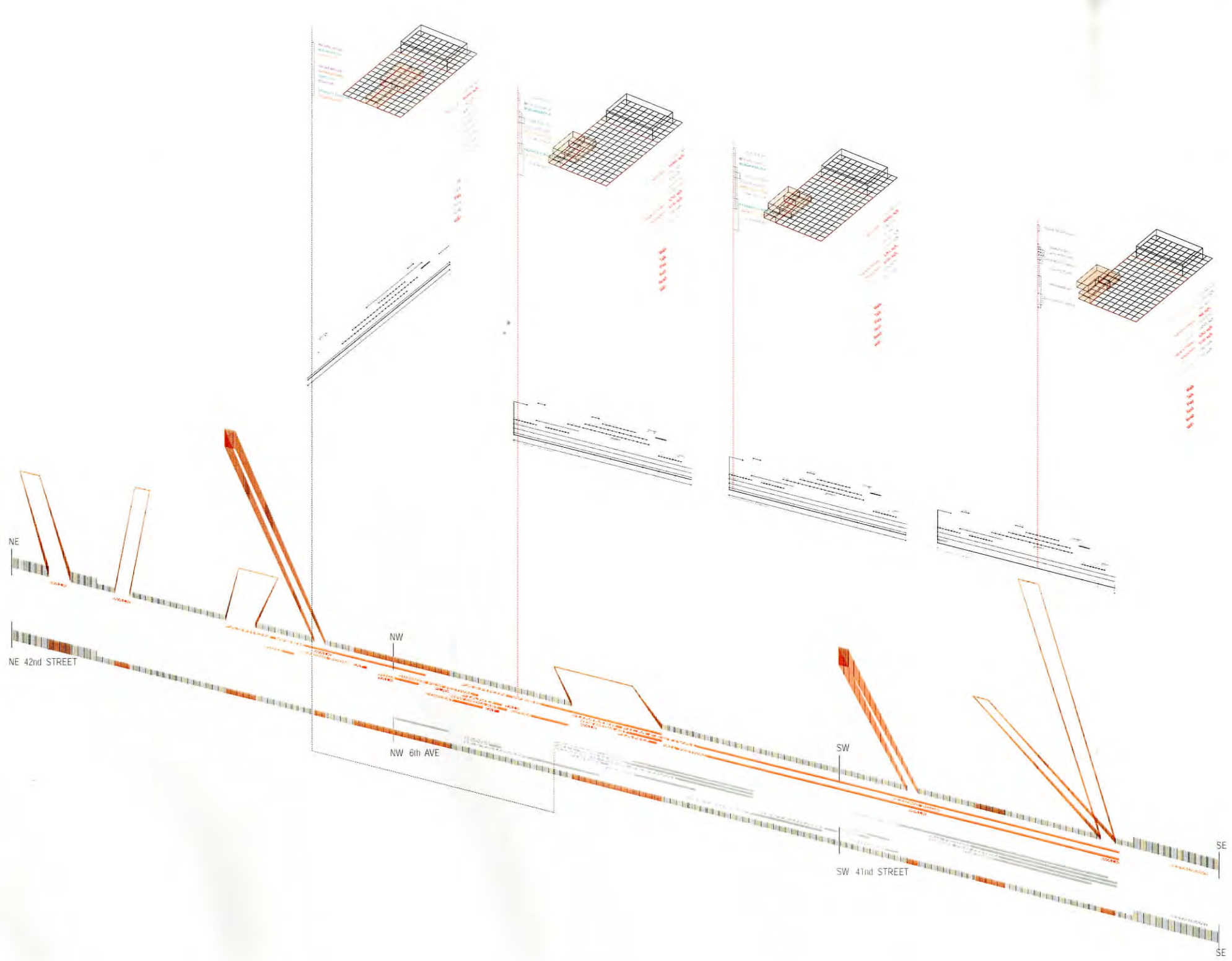



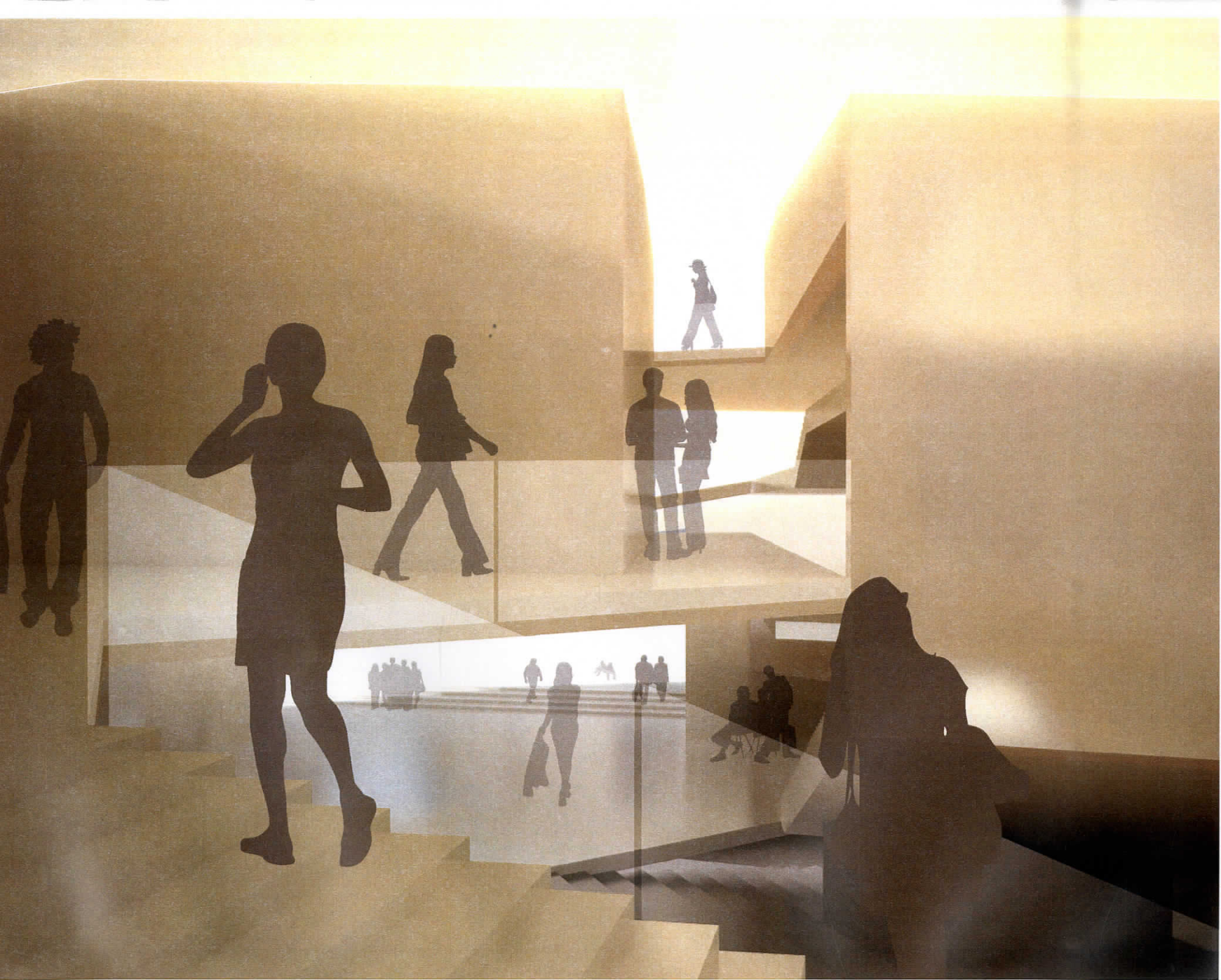



Elevation from East to West

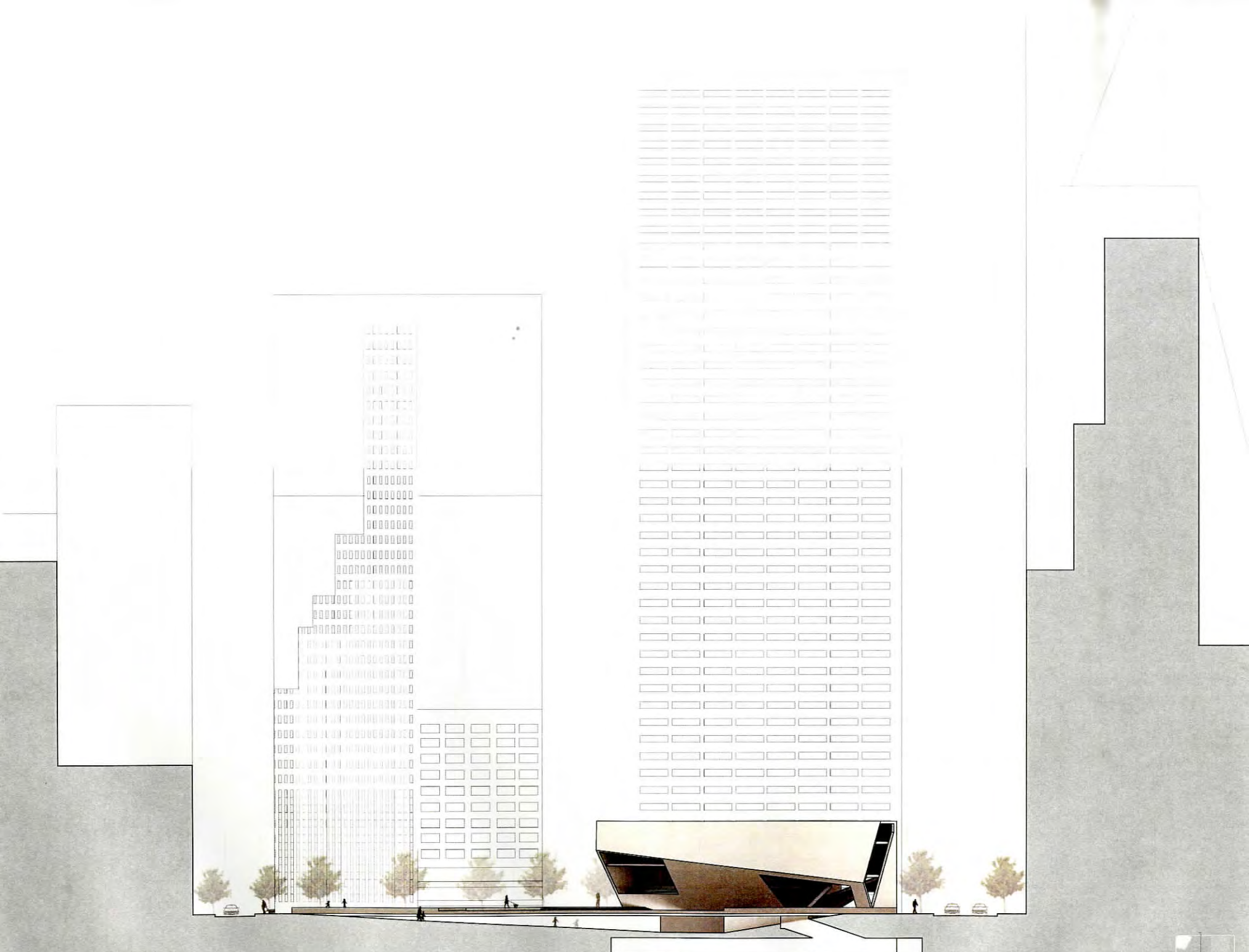

Elevation from North to South



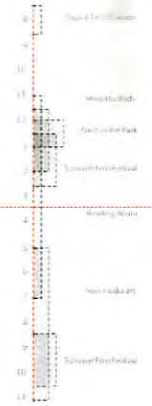
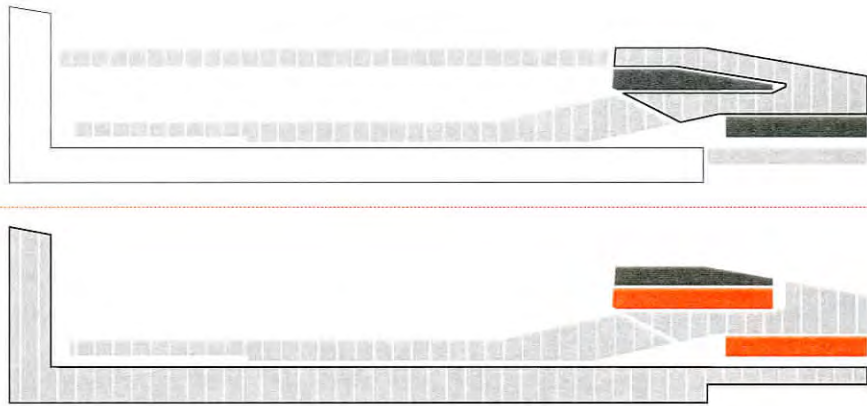

Different Program Over Time



Section cutting East to West



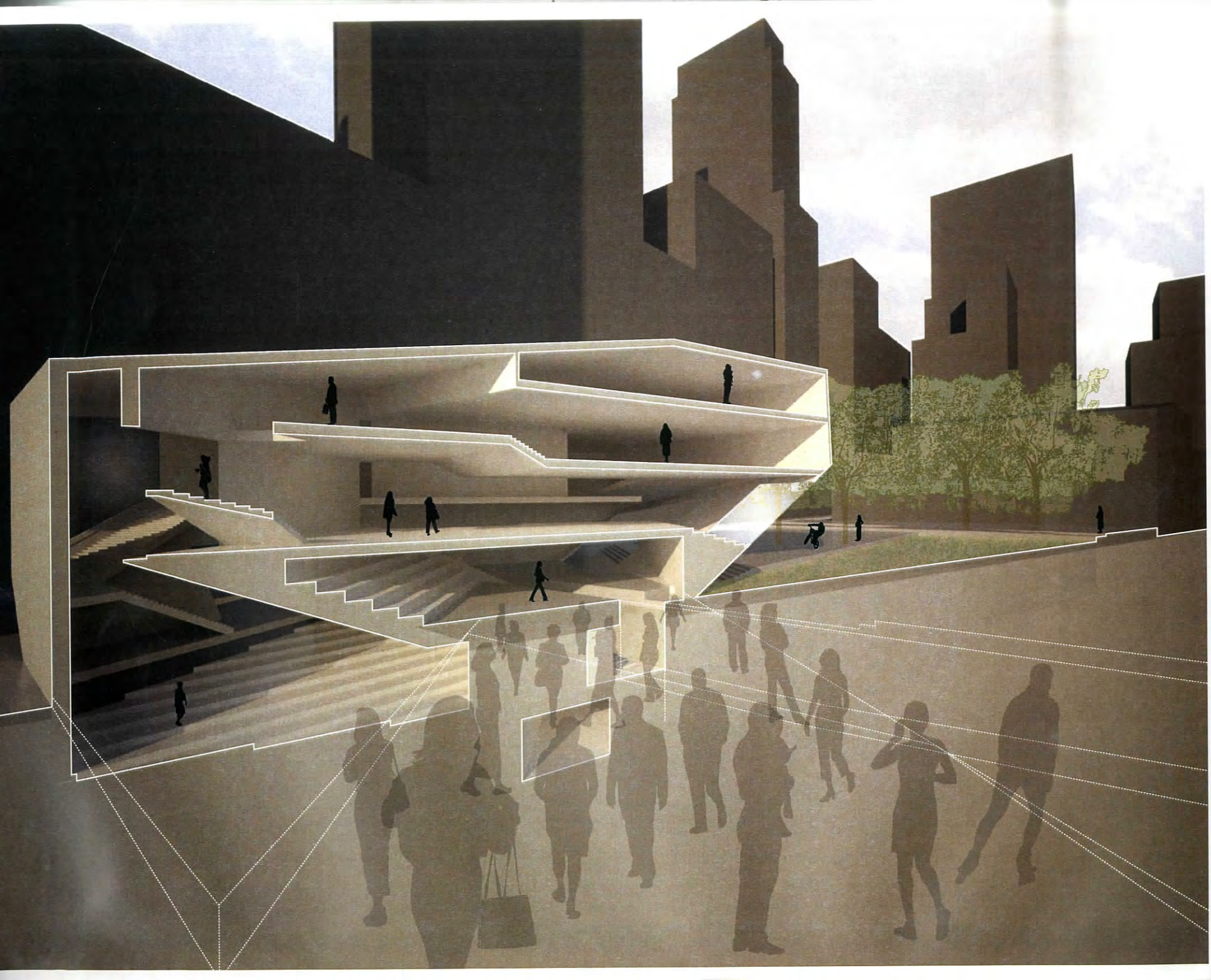

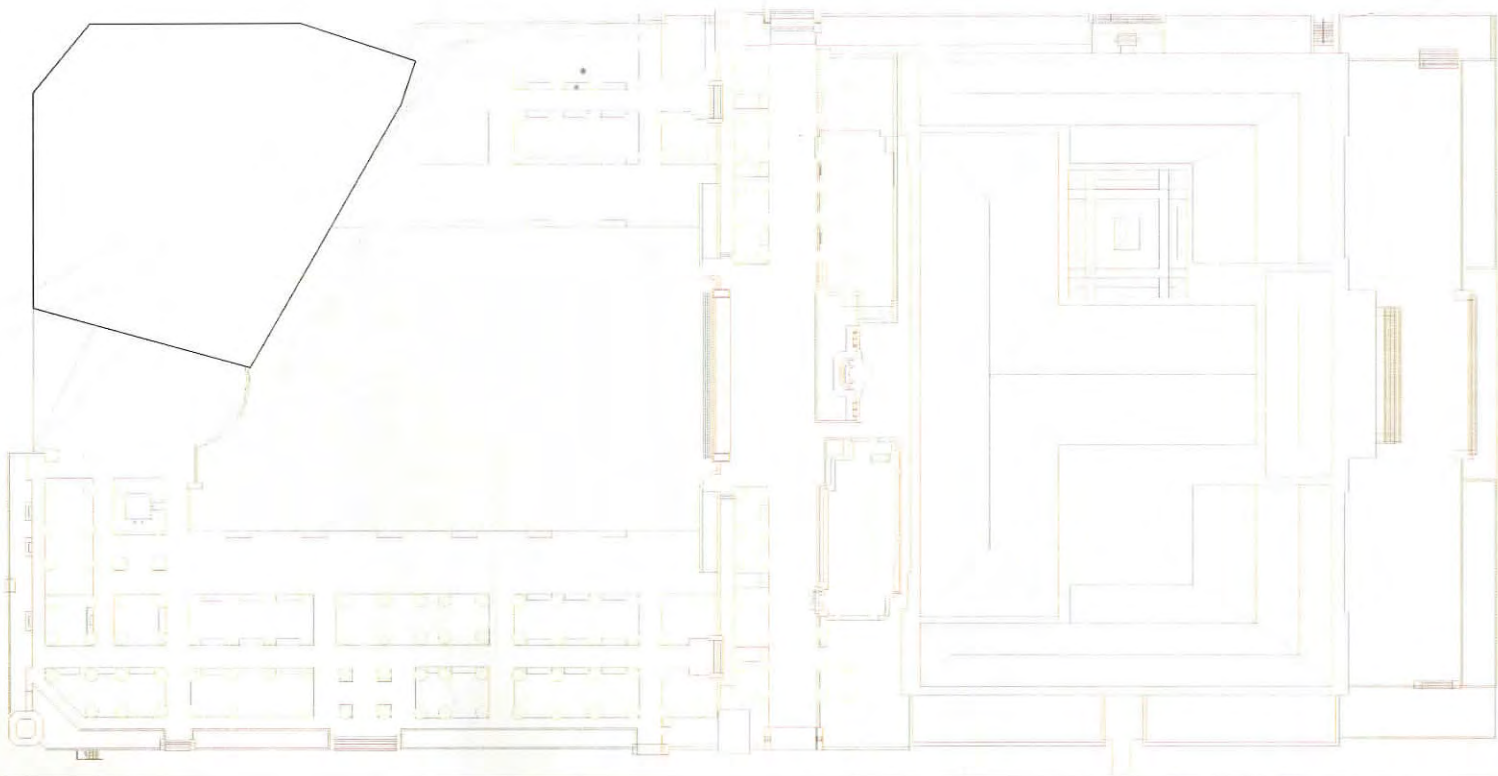
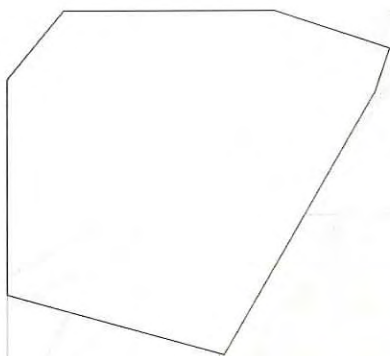

02

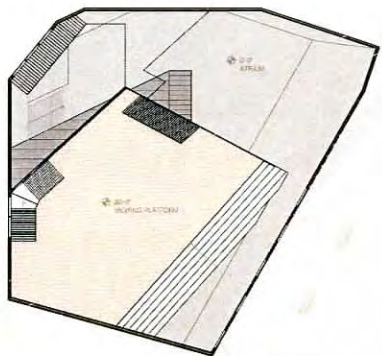

04

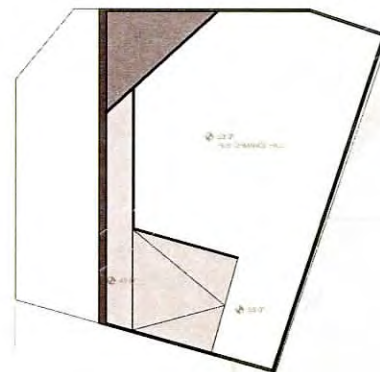

01

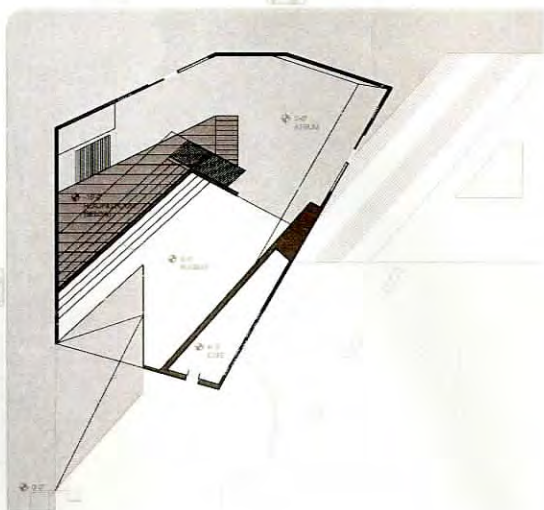

03

